



Logic

Space



Coding



Focus

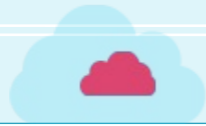

Classroom Discipline

01

Please sit down and keep quiet in class.

02

Please raise your hand if you have any questions

03

Please observe carefully when the pictures are played.





The Safety Barrier





Think

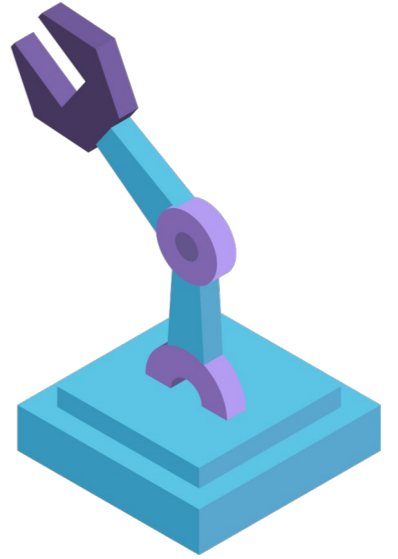

1. Kids, what are the things that protect our safety in our lives?
2. What else in life will protect us?





Explore



1. Have you ever seen this kind of barrier?

2. What are these barriers used for?





Build

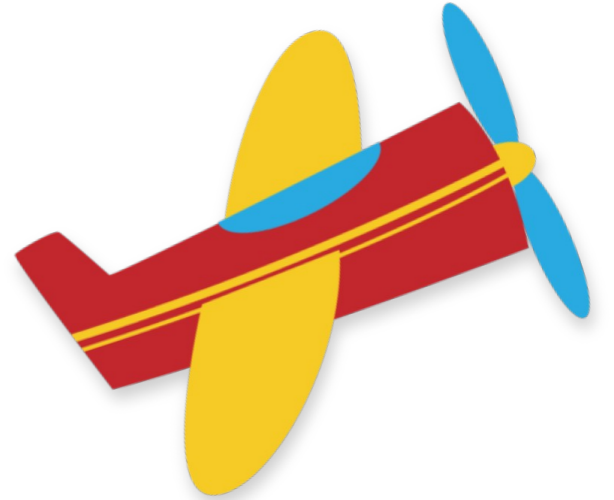

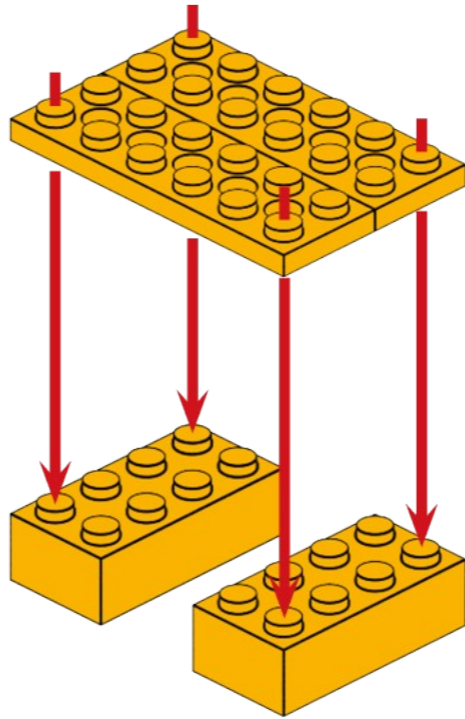

2x6

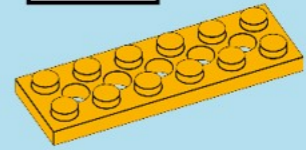

x2

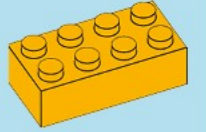

x2

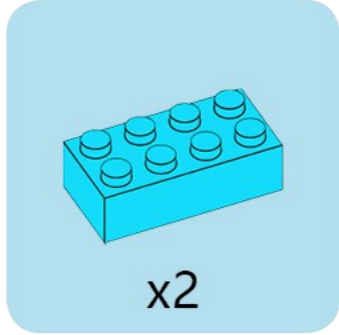
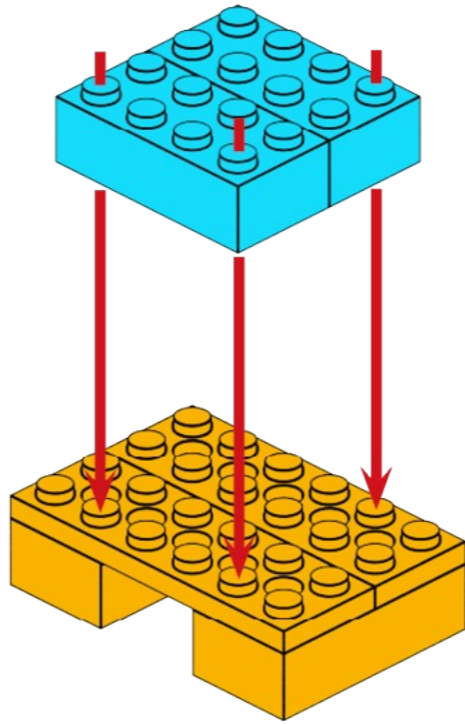

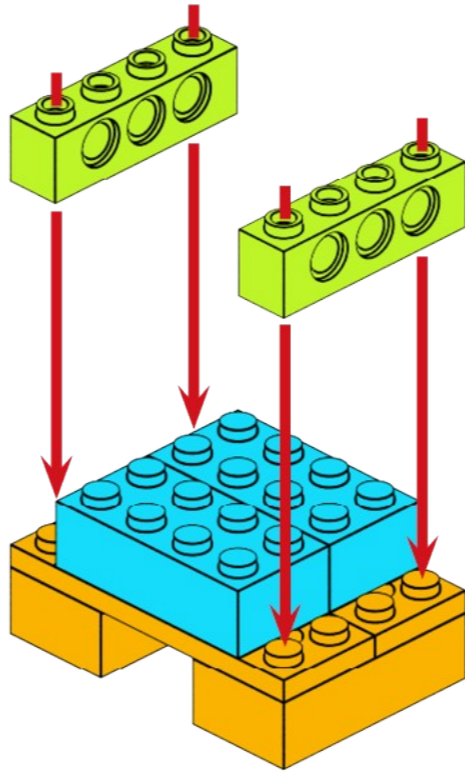

4

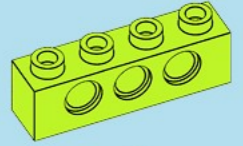

x2

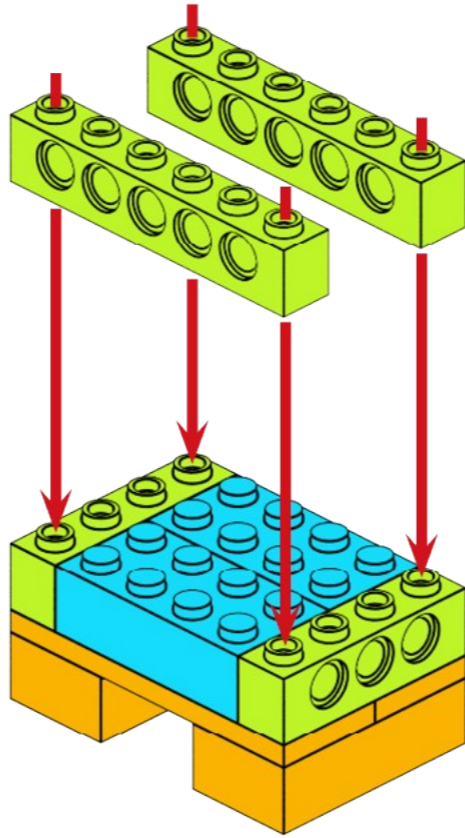

6

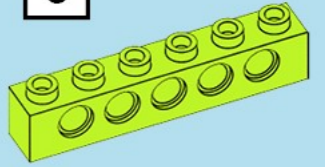

x2

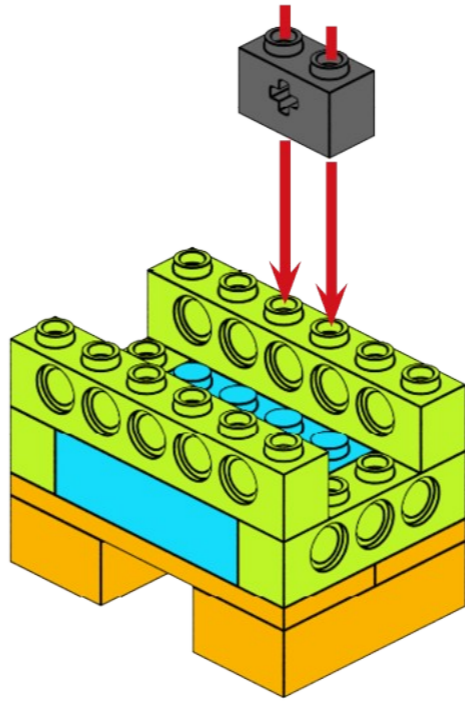

x1

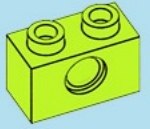
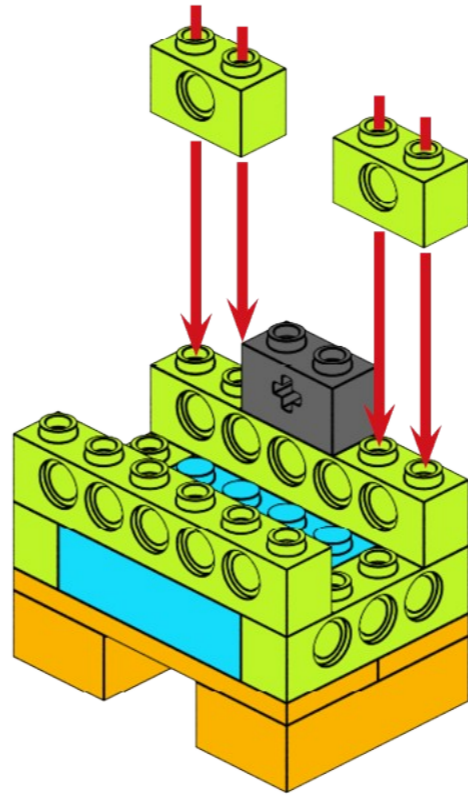

x2

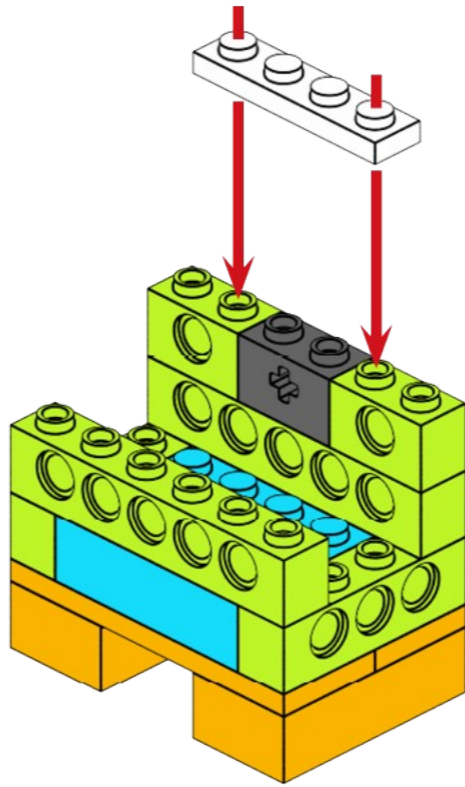

1x4

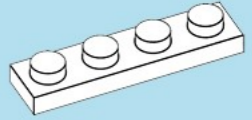

x1

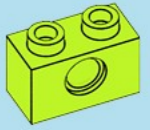
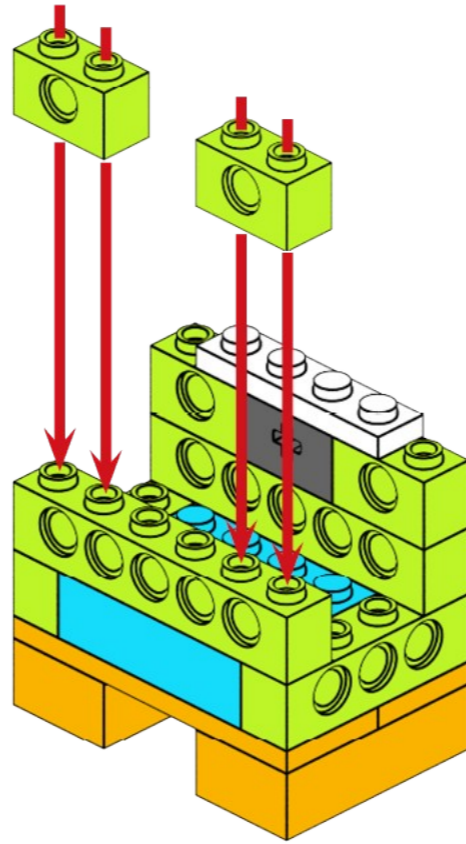

x2

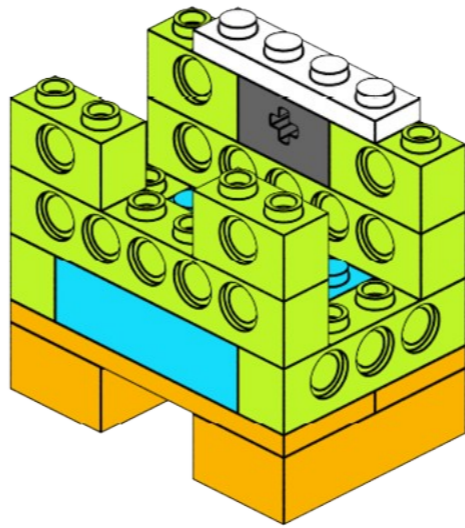

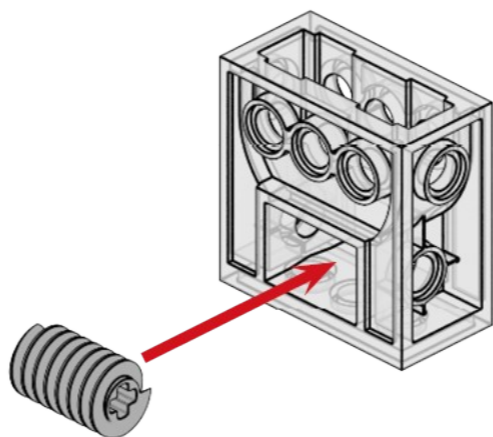
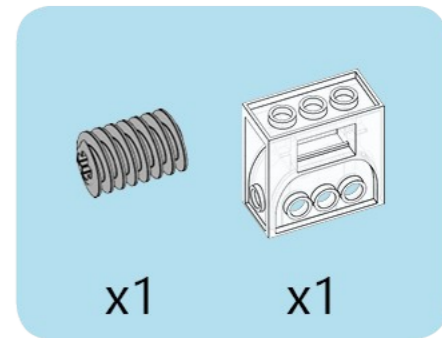

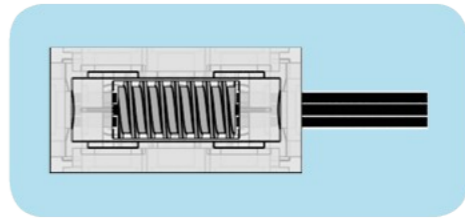
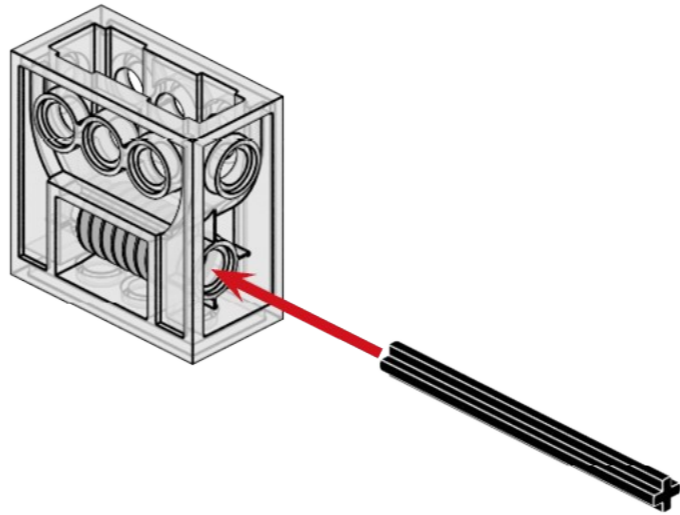
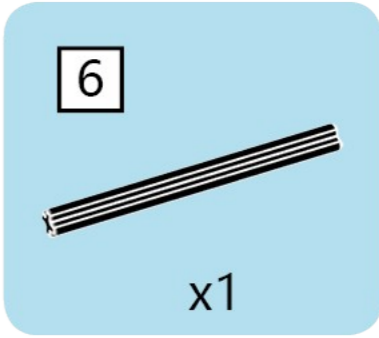



x2

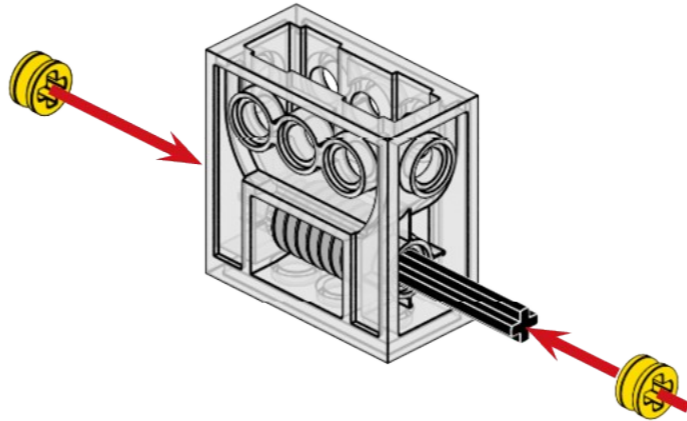



x1

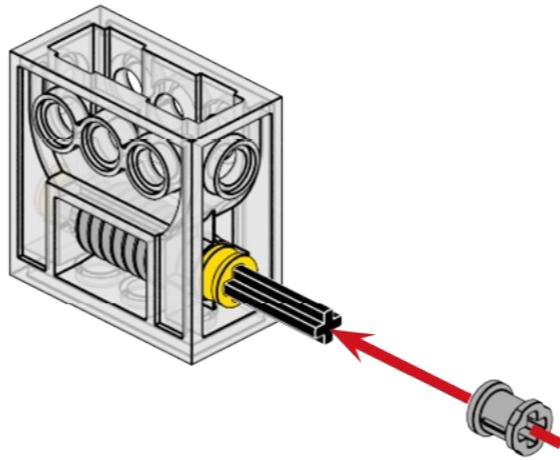

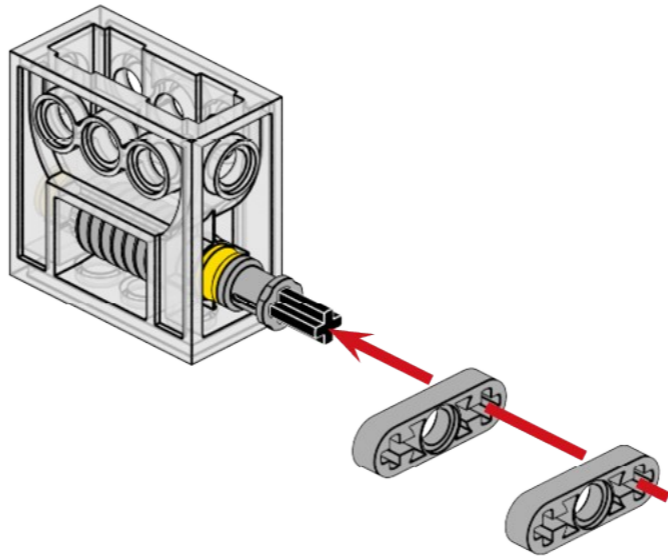
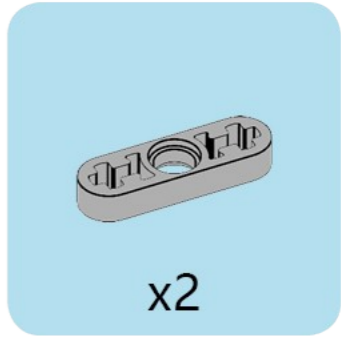

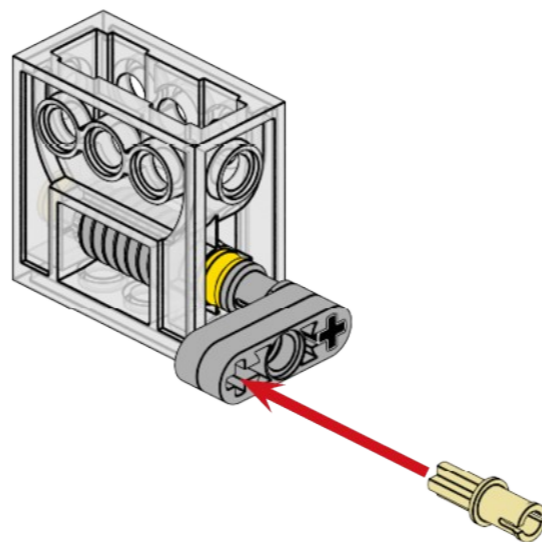
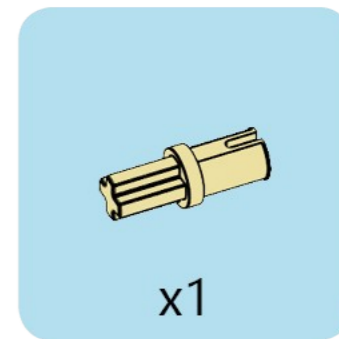

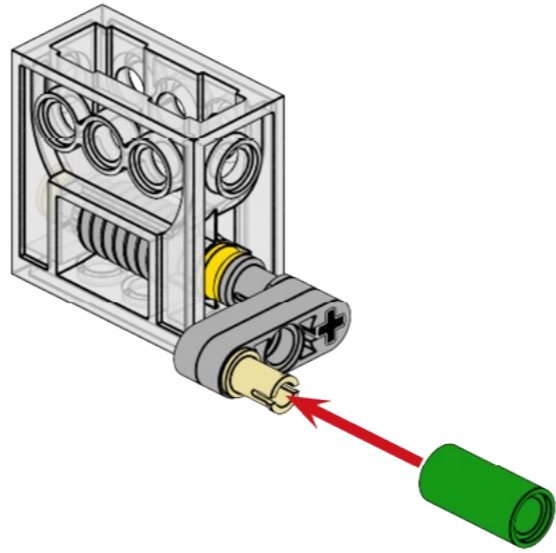
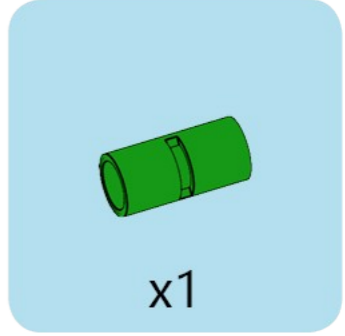

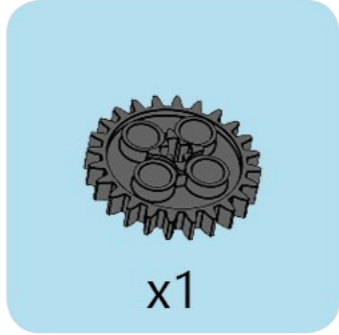
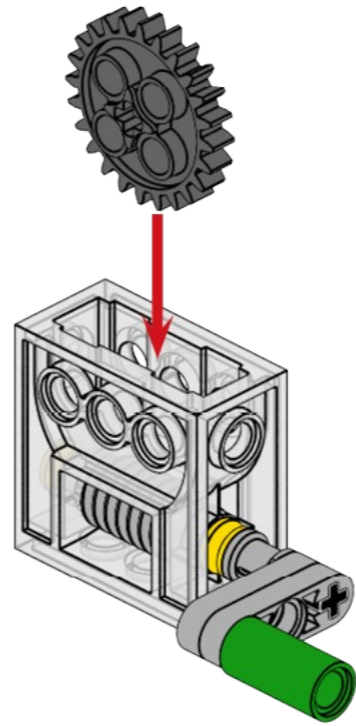

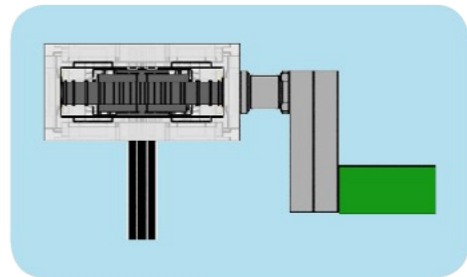
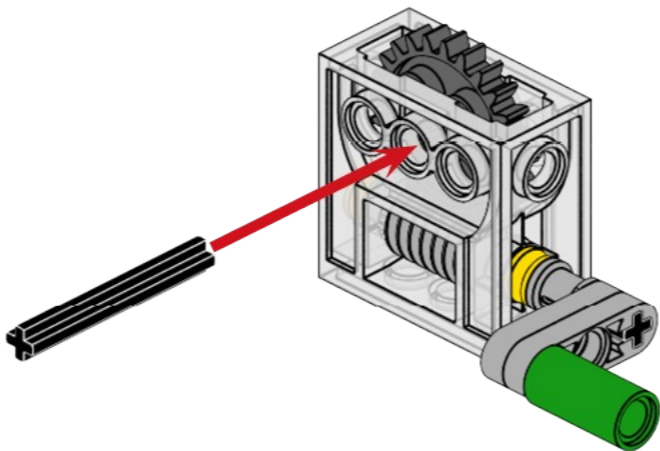
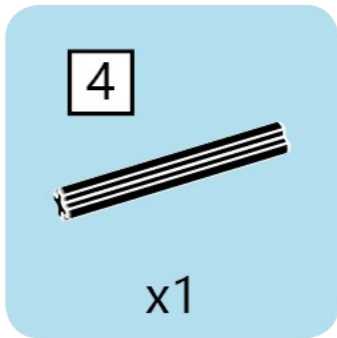

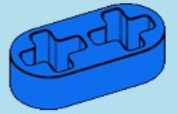

x2

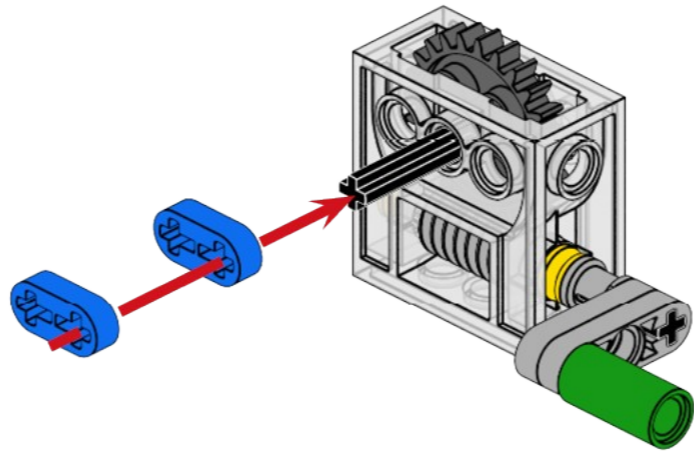

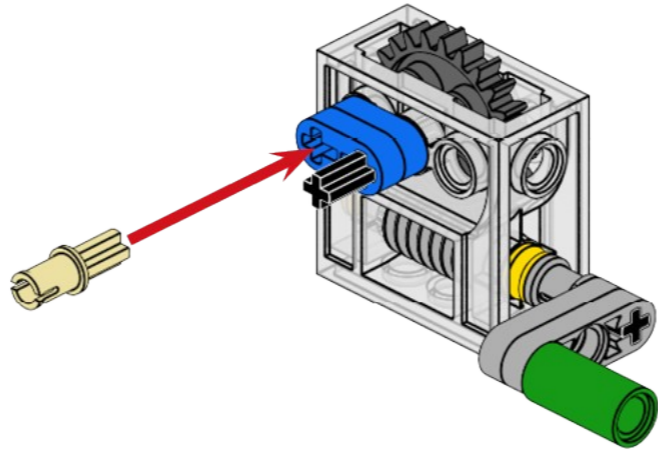
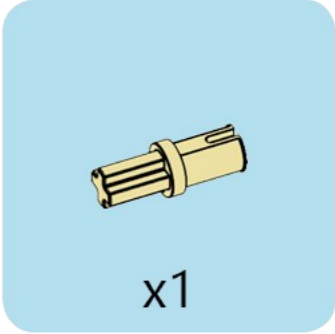

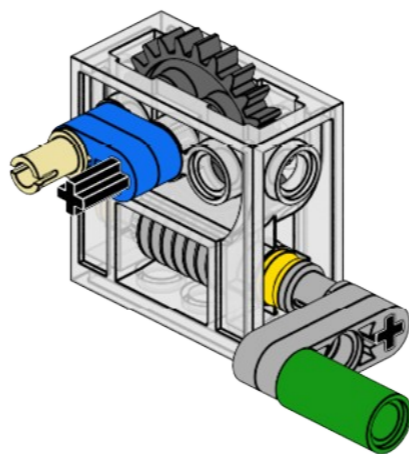

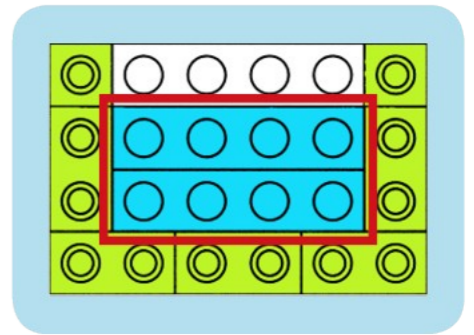
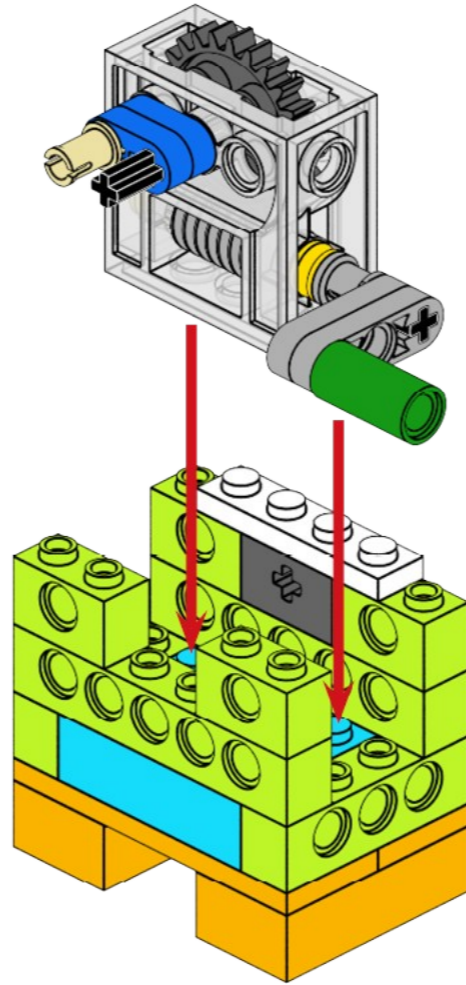

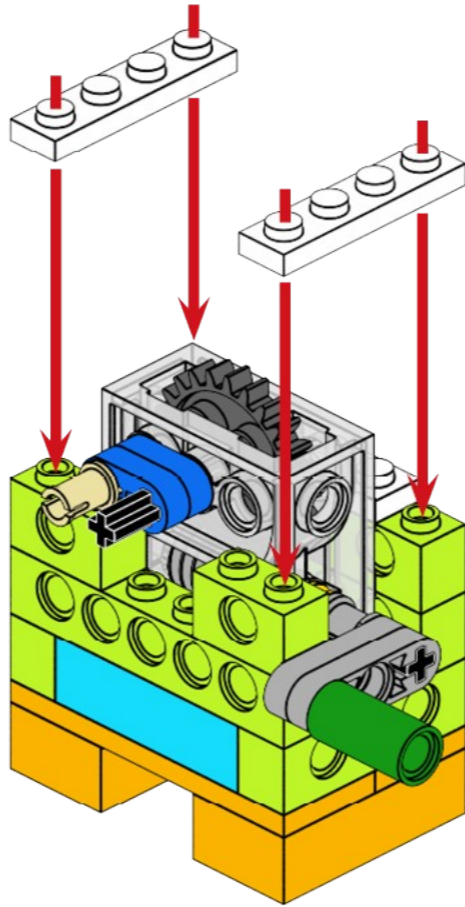

1x4

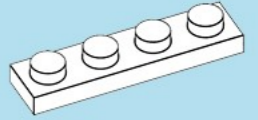

x2



5

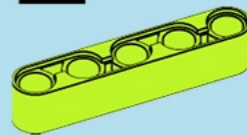

x1

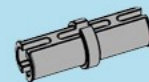

x2

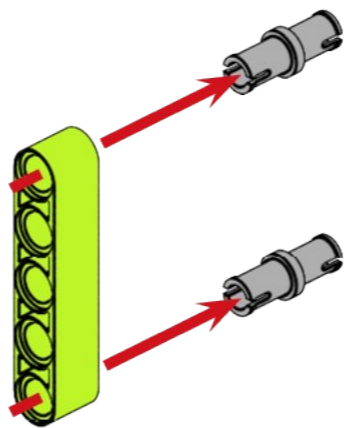

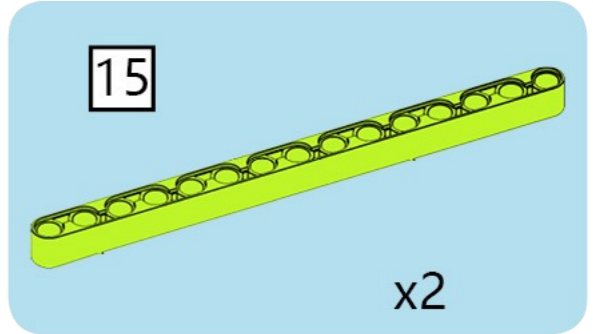
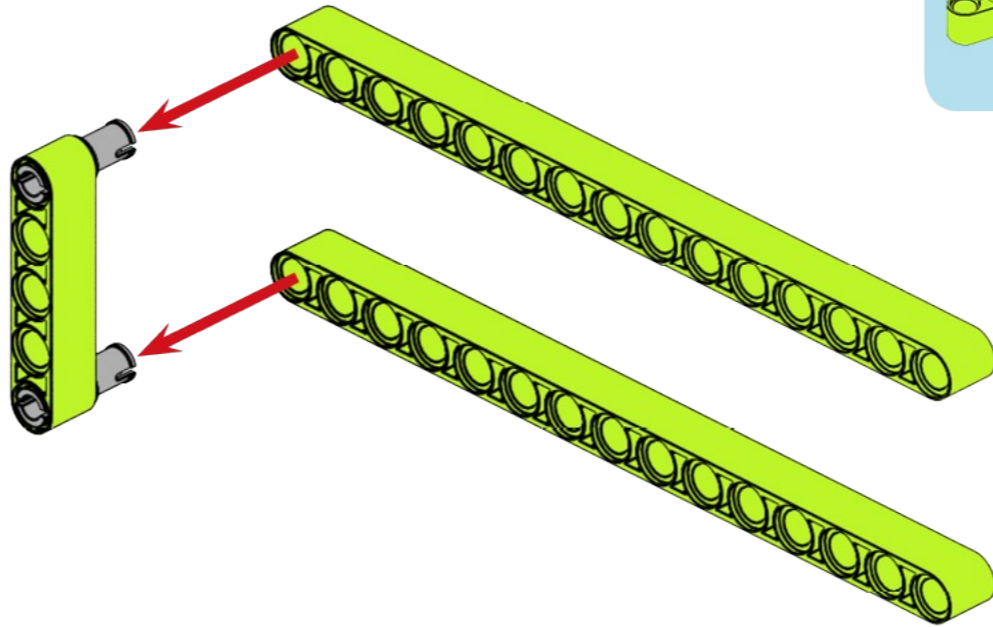

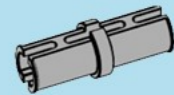
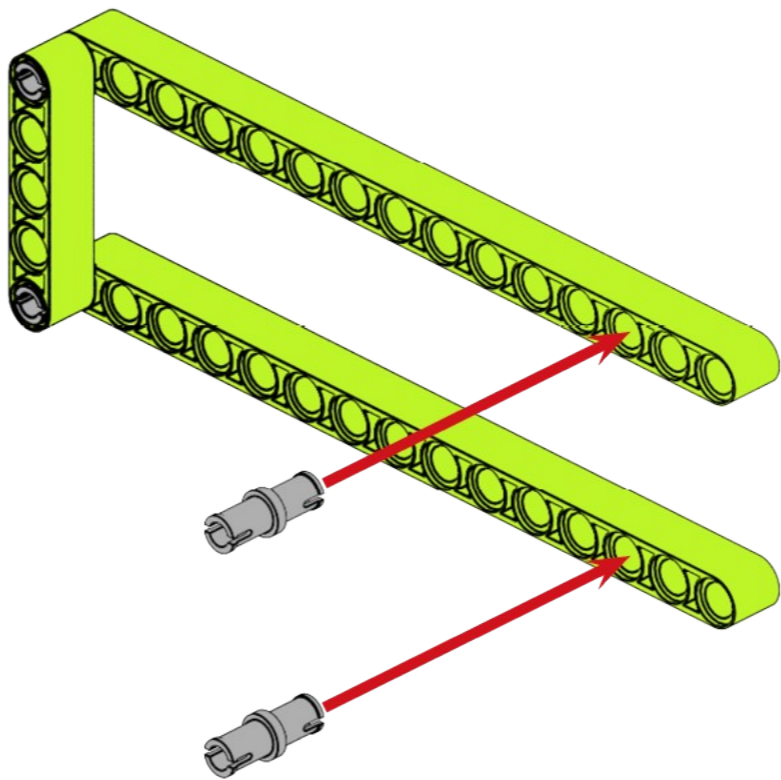

x2

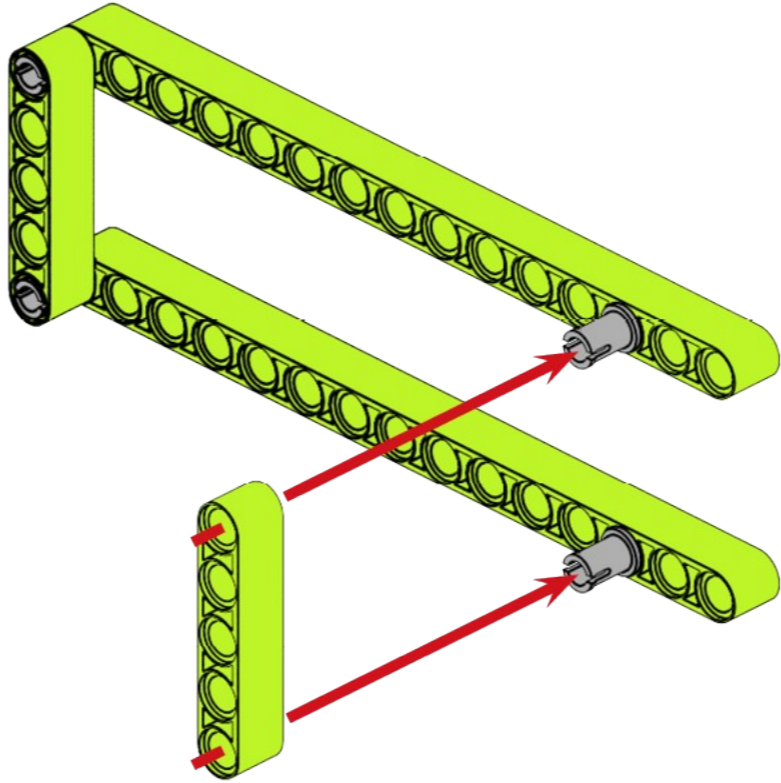
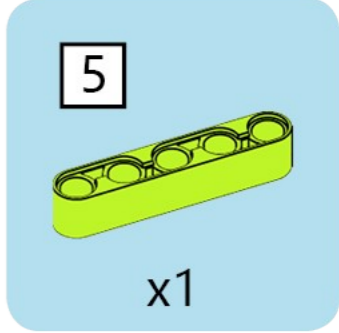

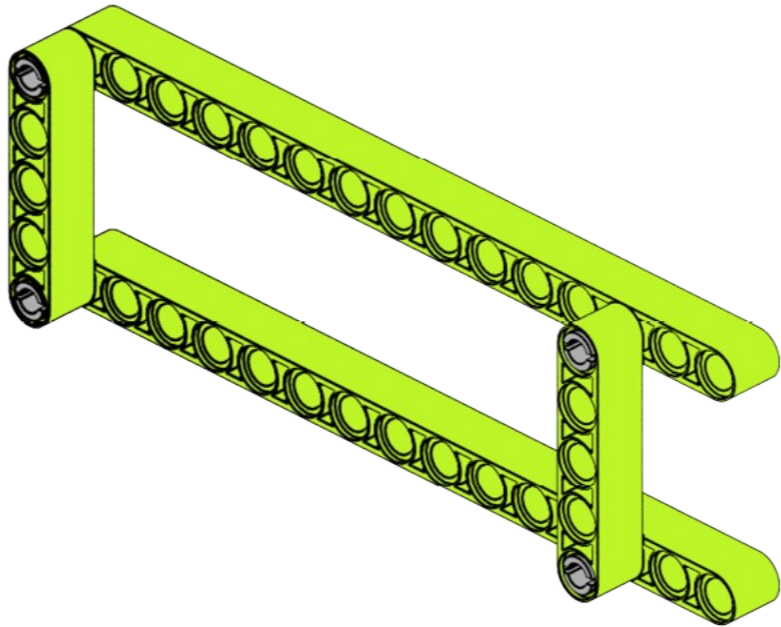

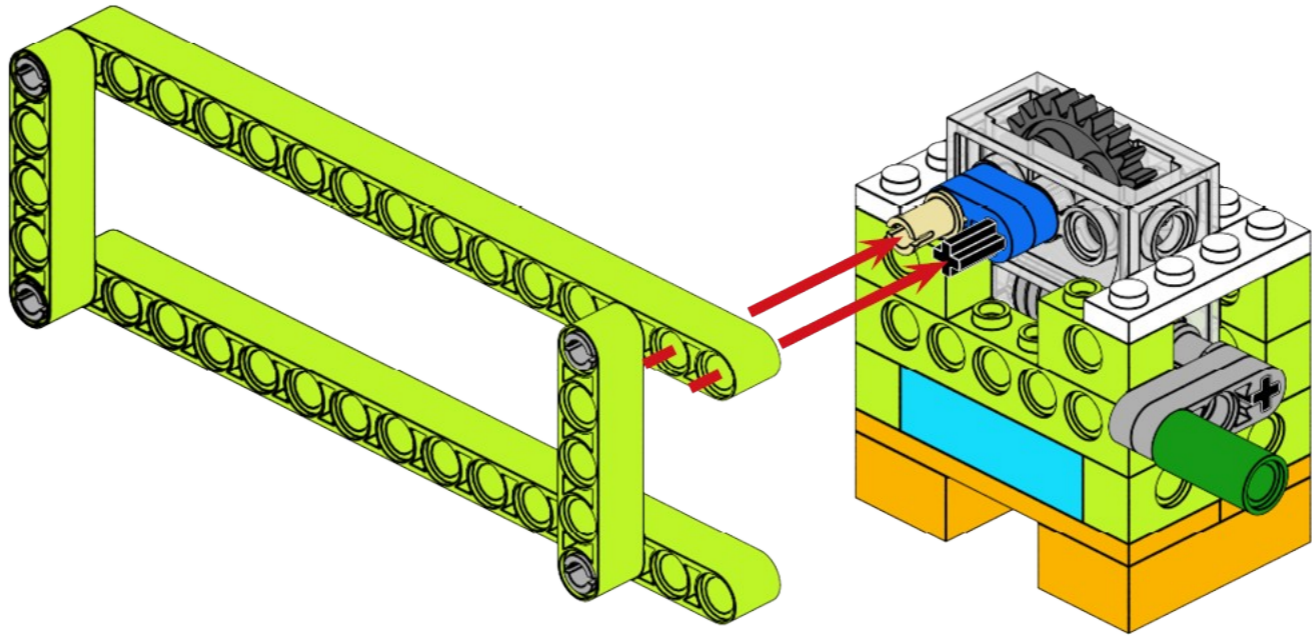

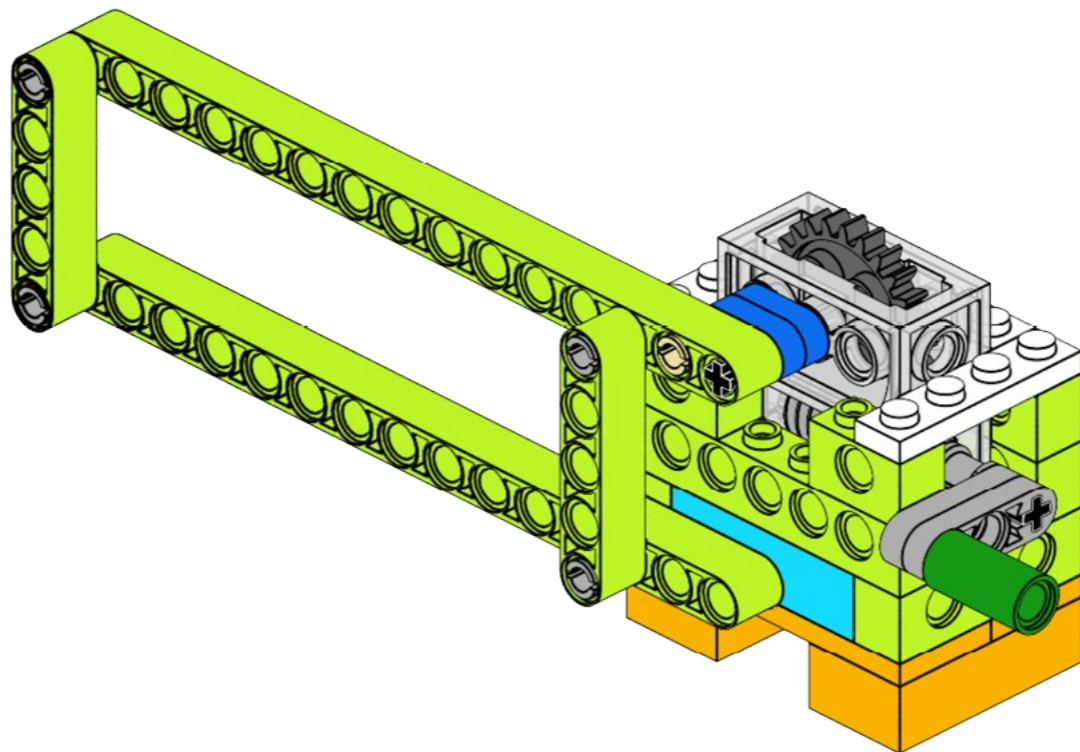

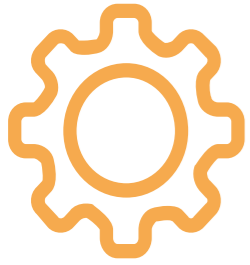

Review

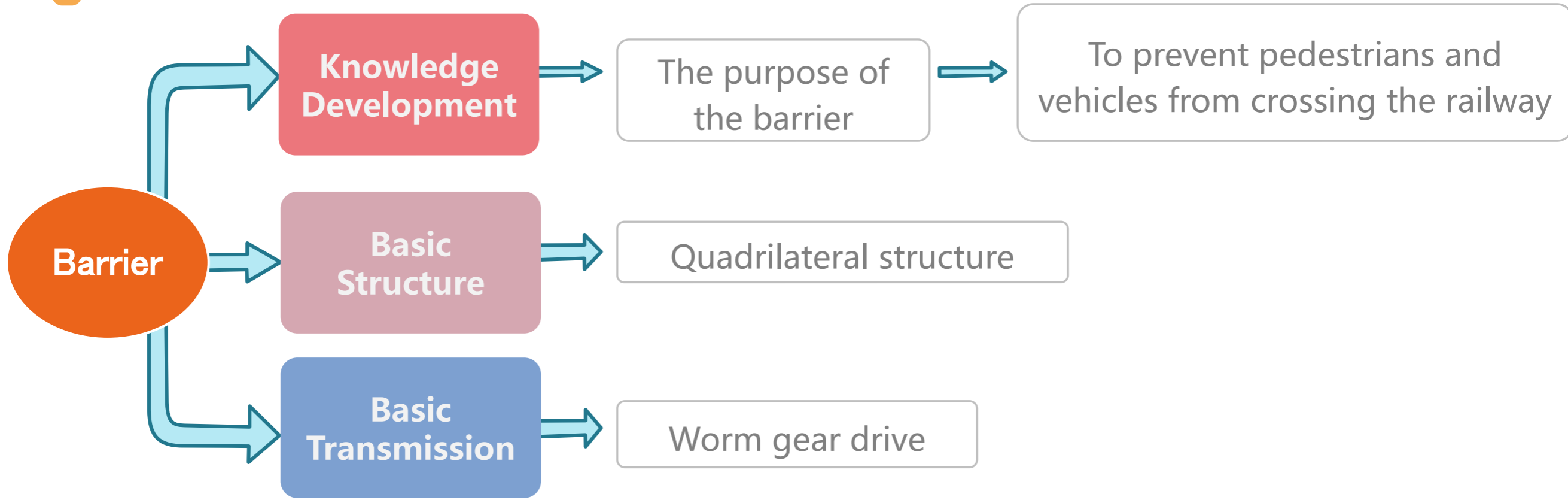



Talk

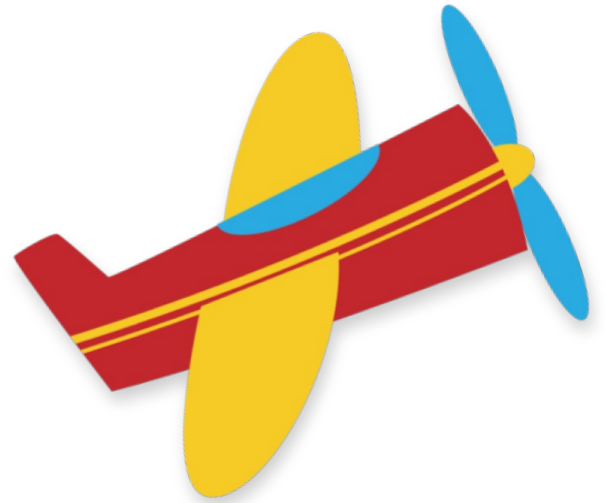



THANKS

