



**Logic**

**Space**



**Coding**



**Focus**

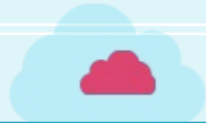

# Classroom Discipline

**01**

Please sit down and keep quiet in class.

**02**

Please raise your hand if you have any questions

**03**

Please observe carefully when the pictures are played.





# The swing





**Think**

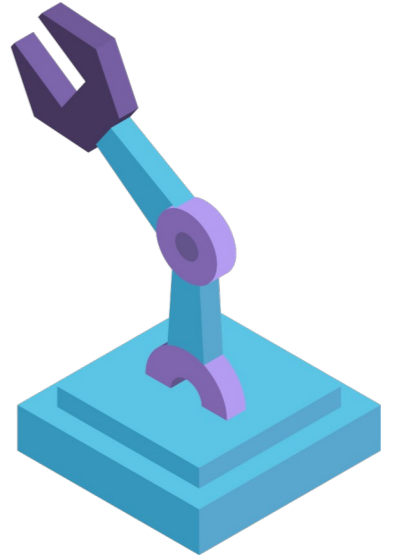



1. Kids, what is your favorite amusement facility?

2. Look at what this kid is doing?

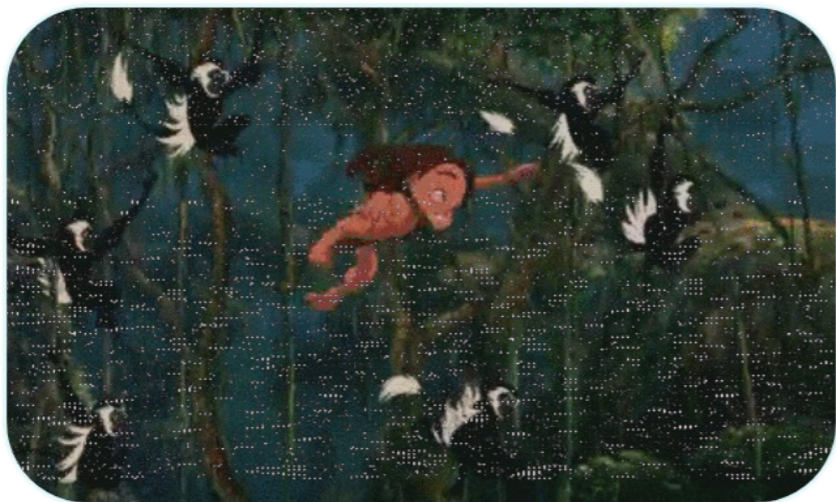



**Explore**

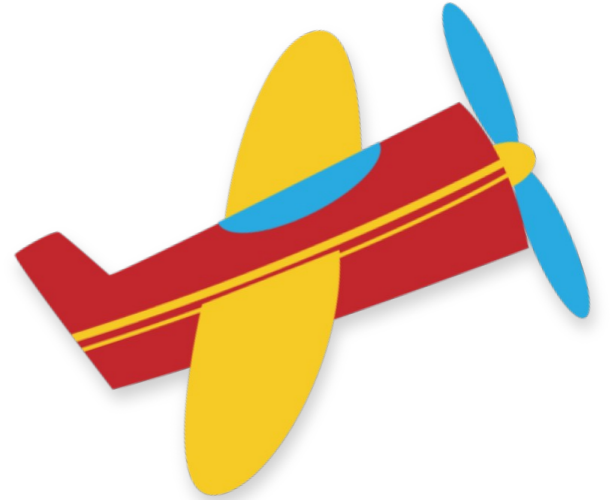



# 1. What should we pay attention to when swinging?





**Build**

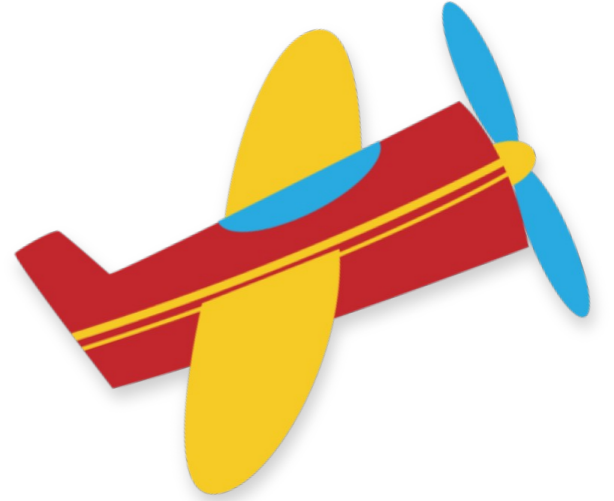

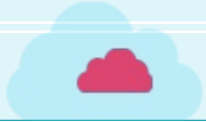

**Tripod**



**rope**

**Swing Chair**

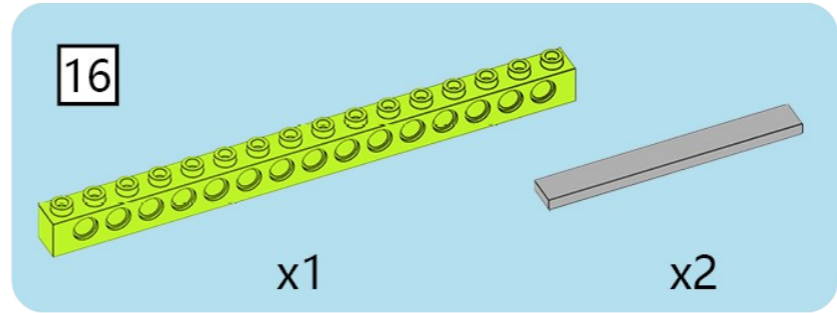
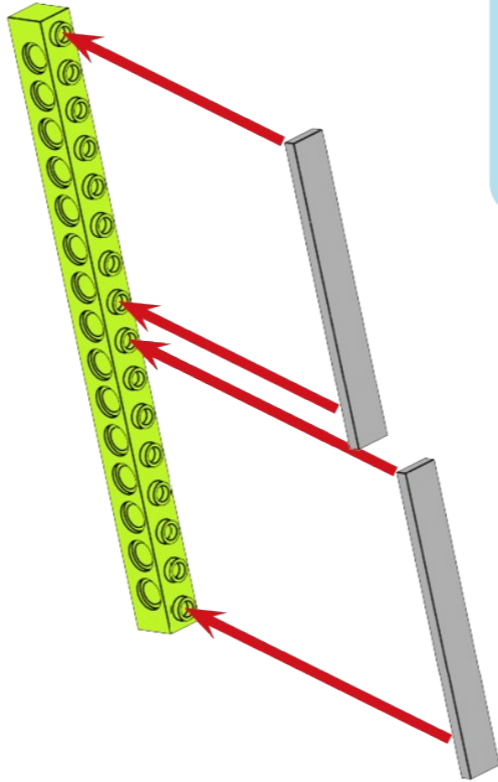
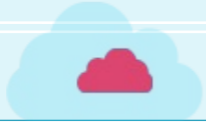

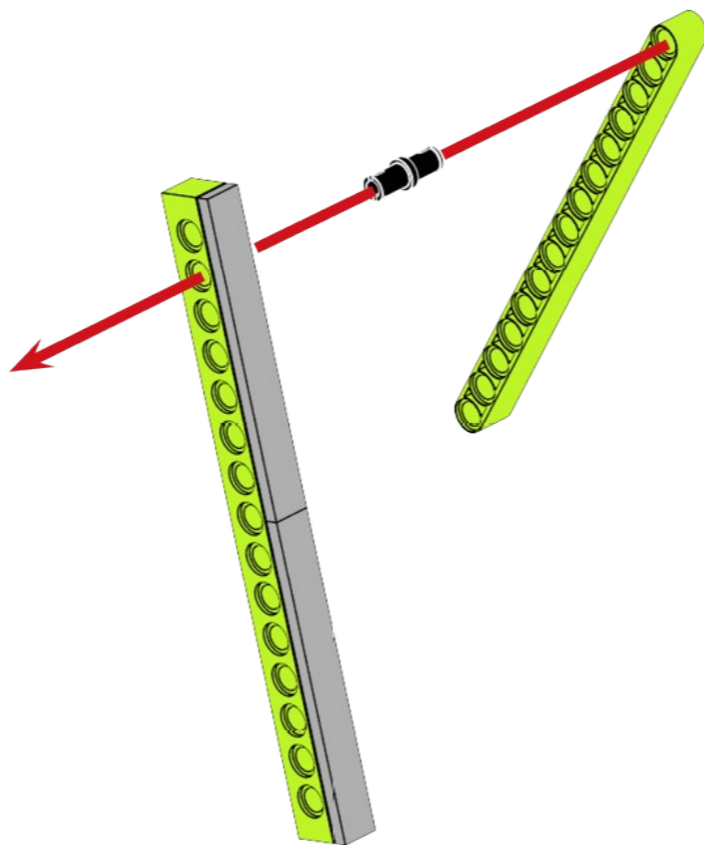

15

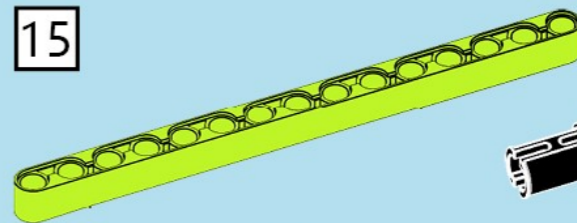

x1

x1

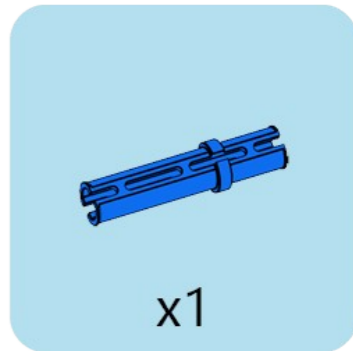
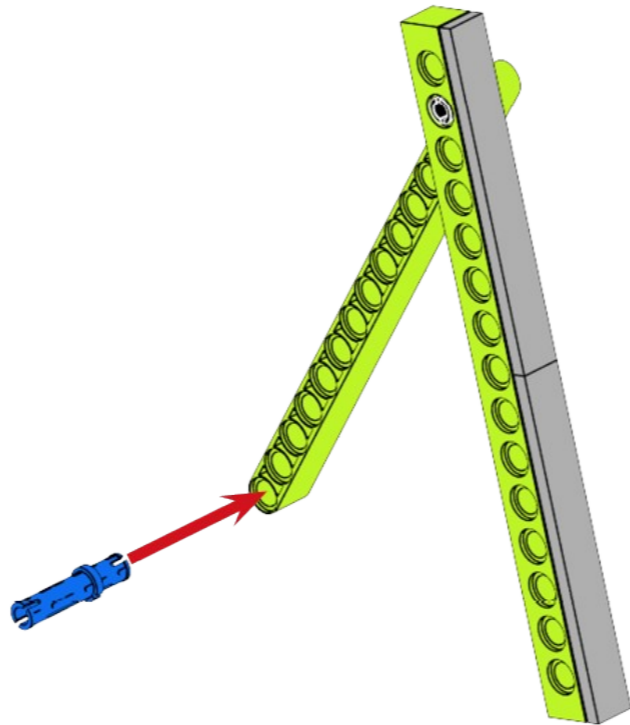

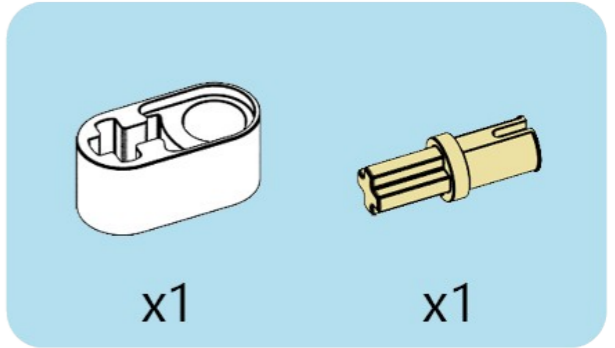
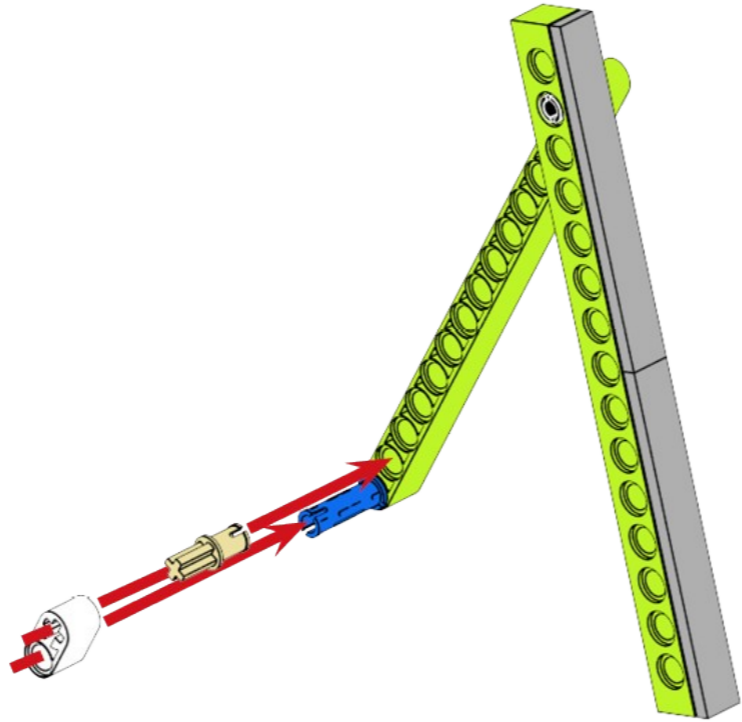

x1

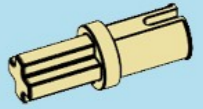

x1

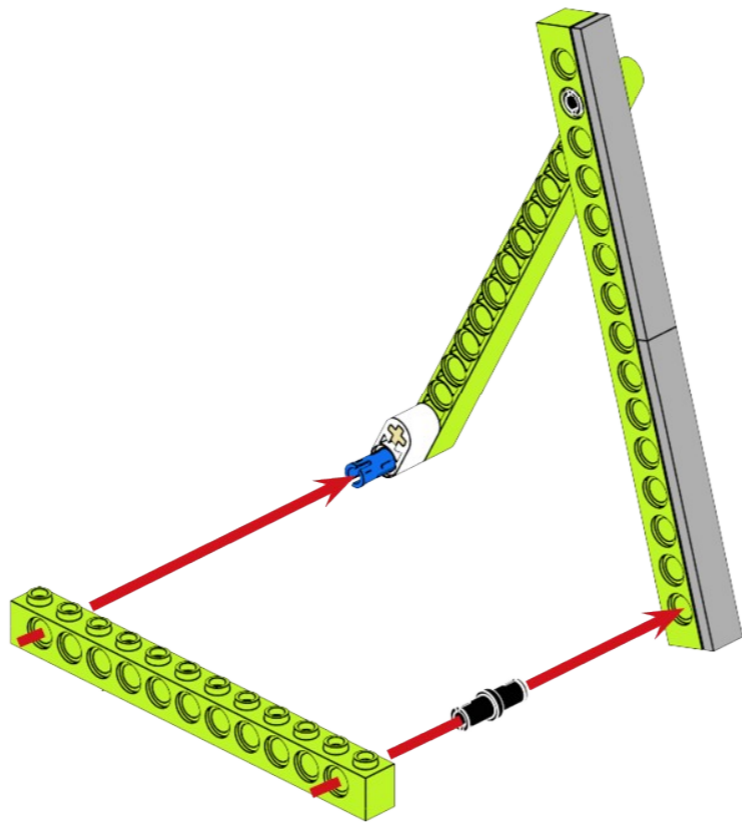

12

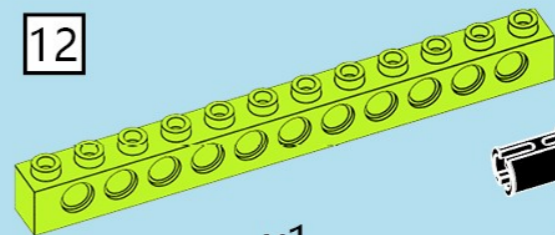

x1

x1



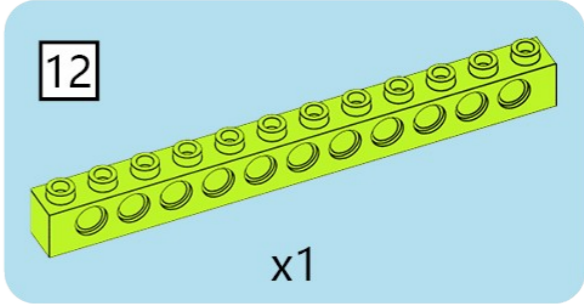
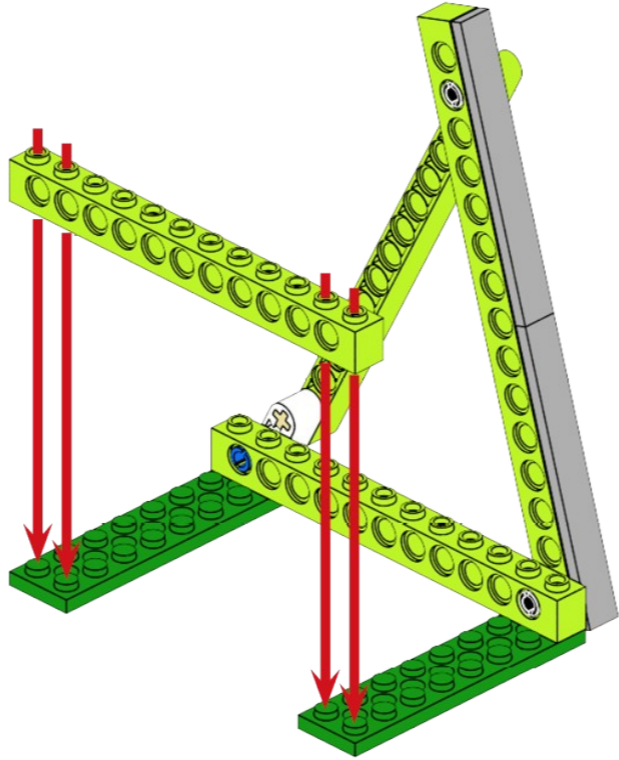
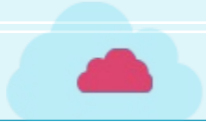

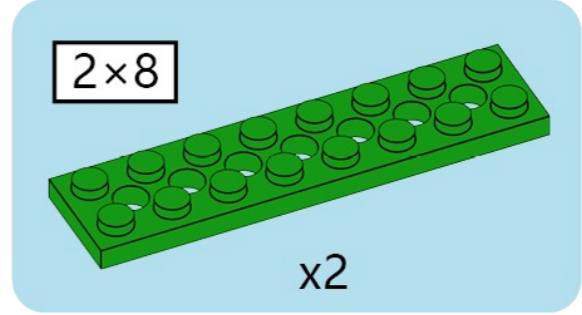
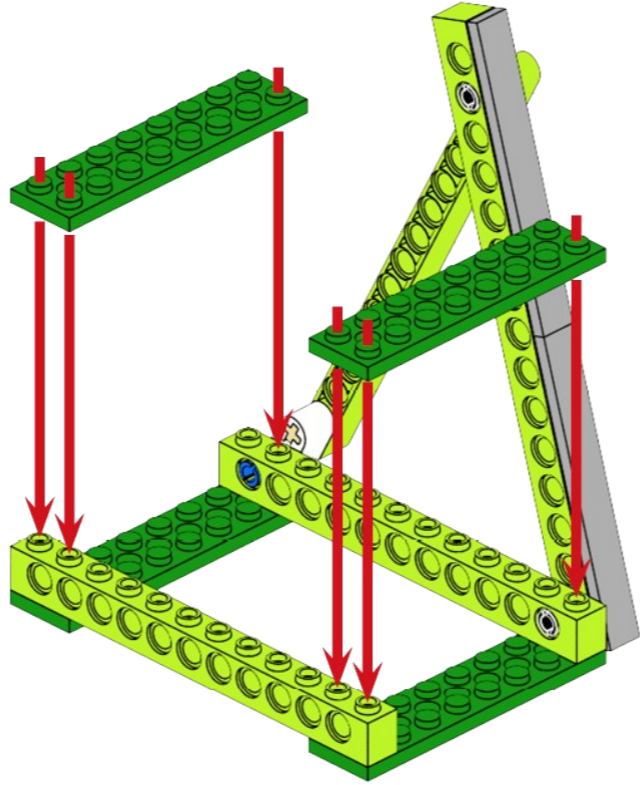
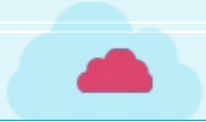

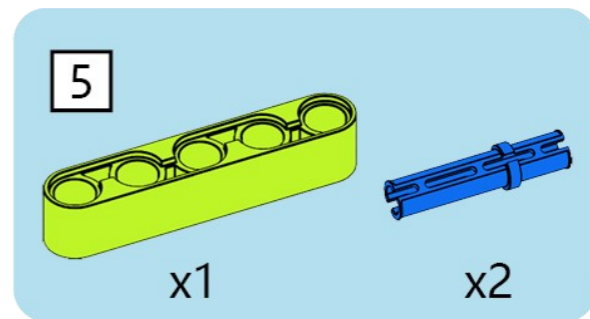
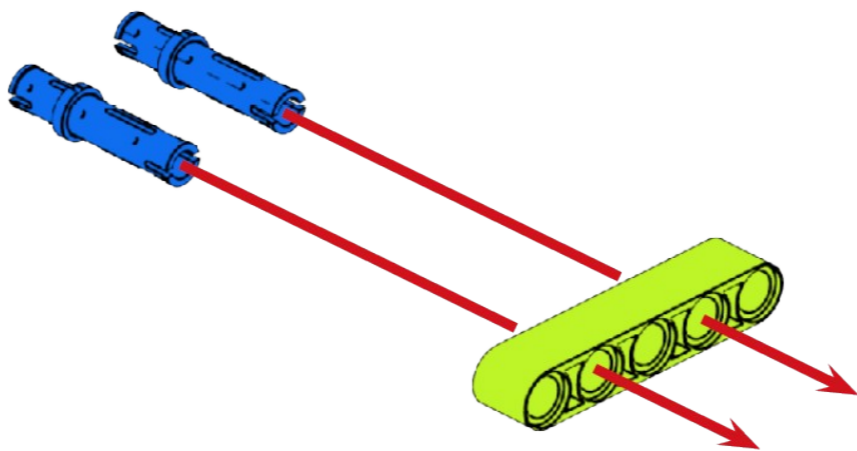

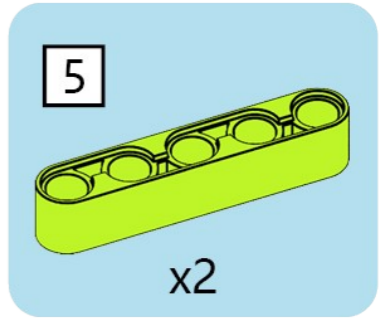
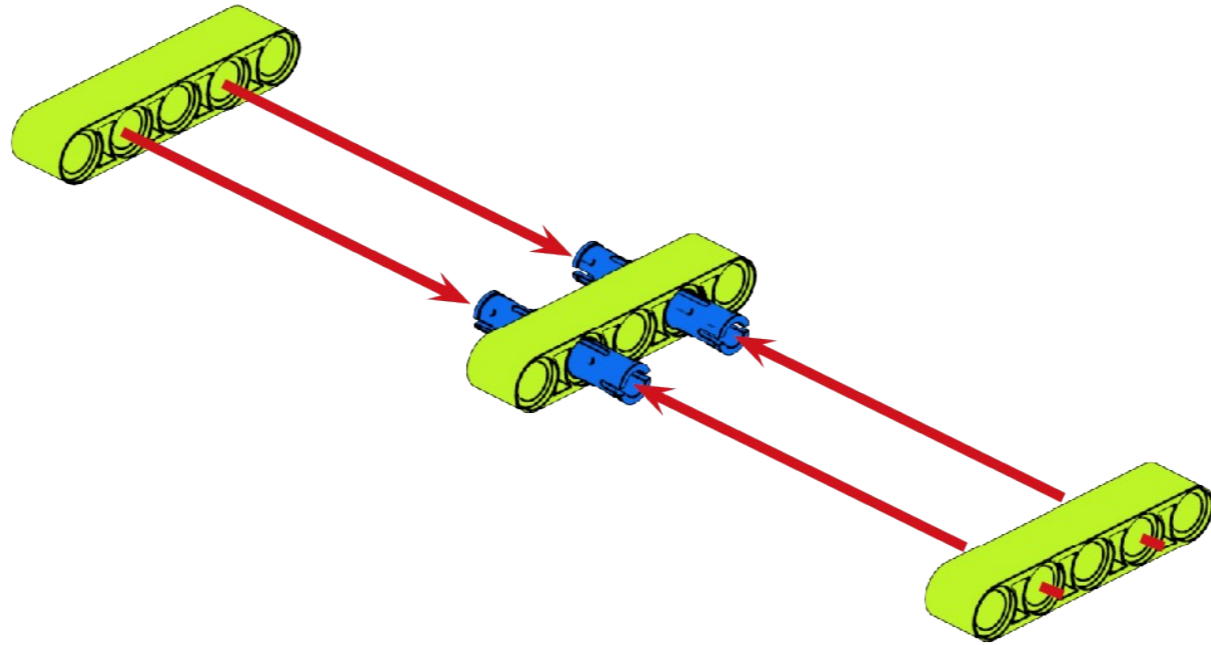

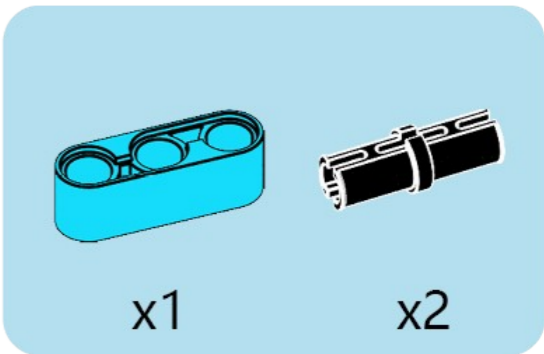
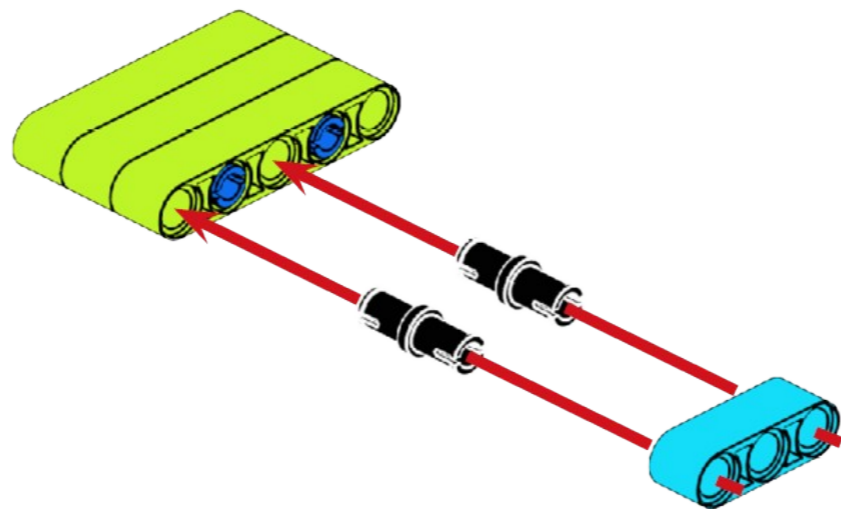

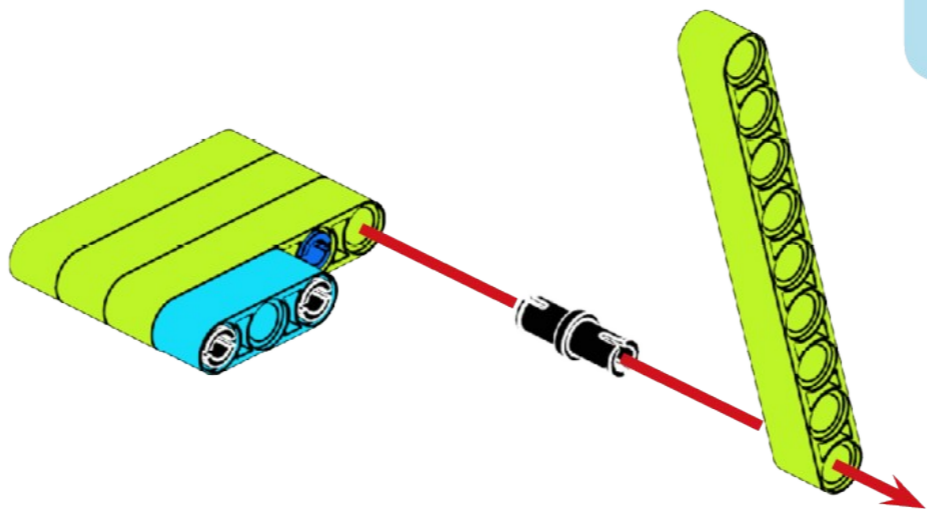

9

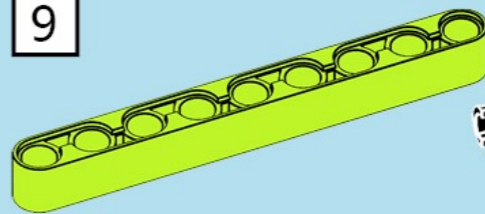

x1



x1

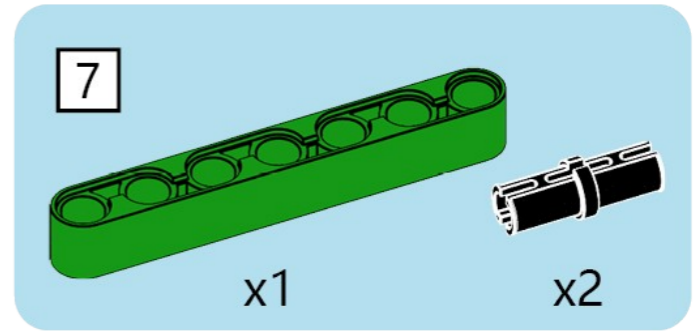
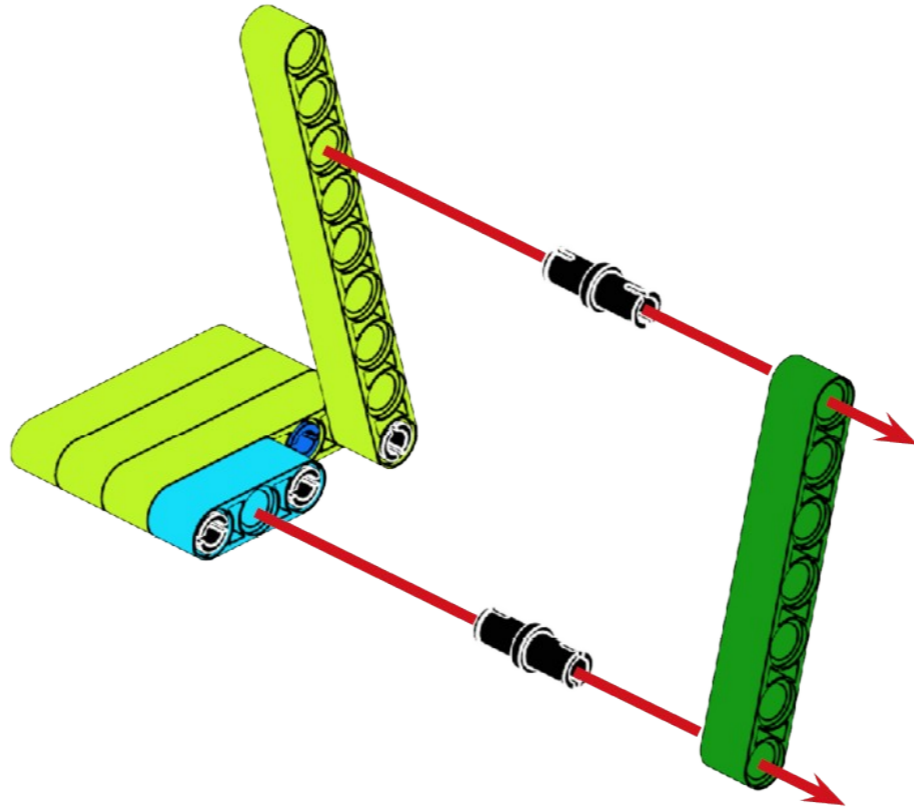
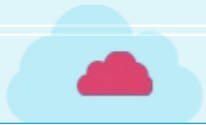

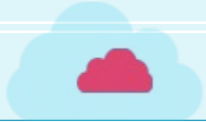

6



x2



x1

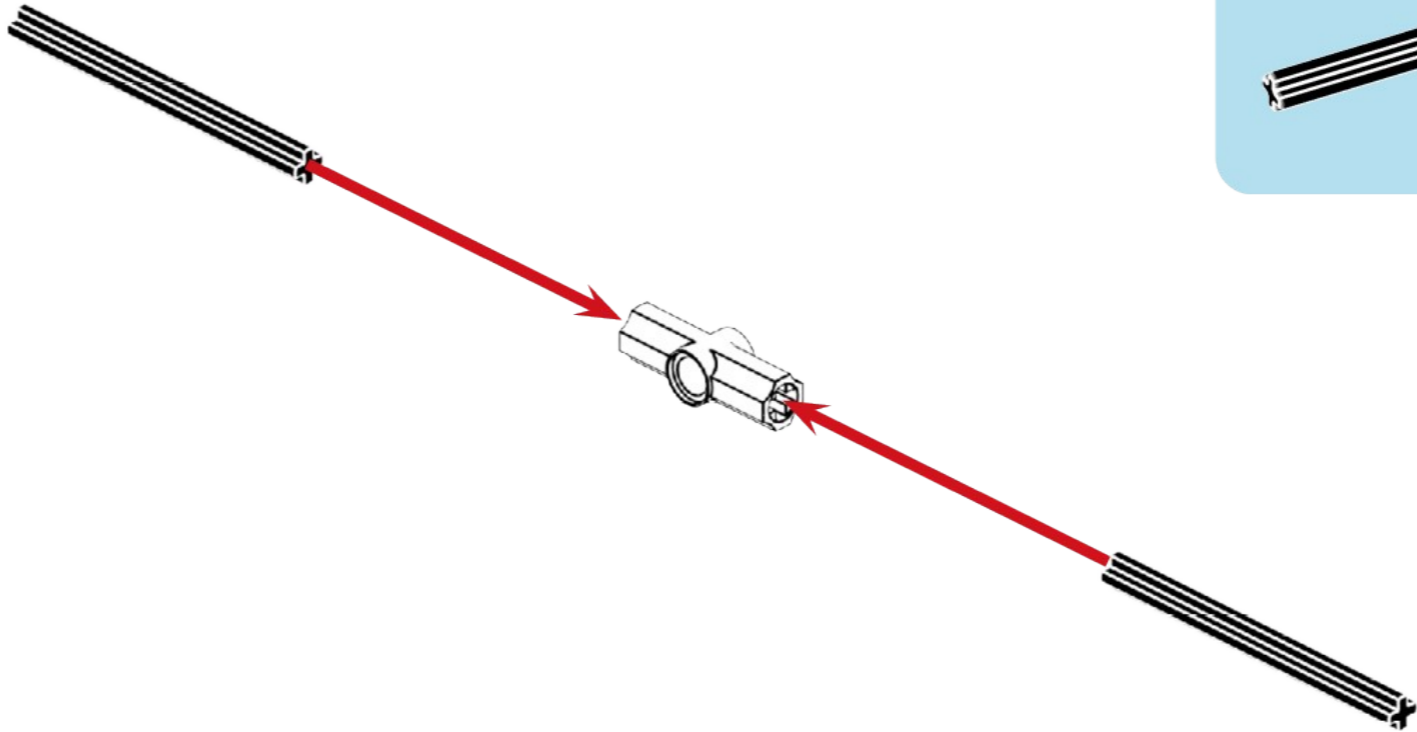

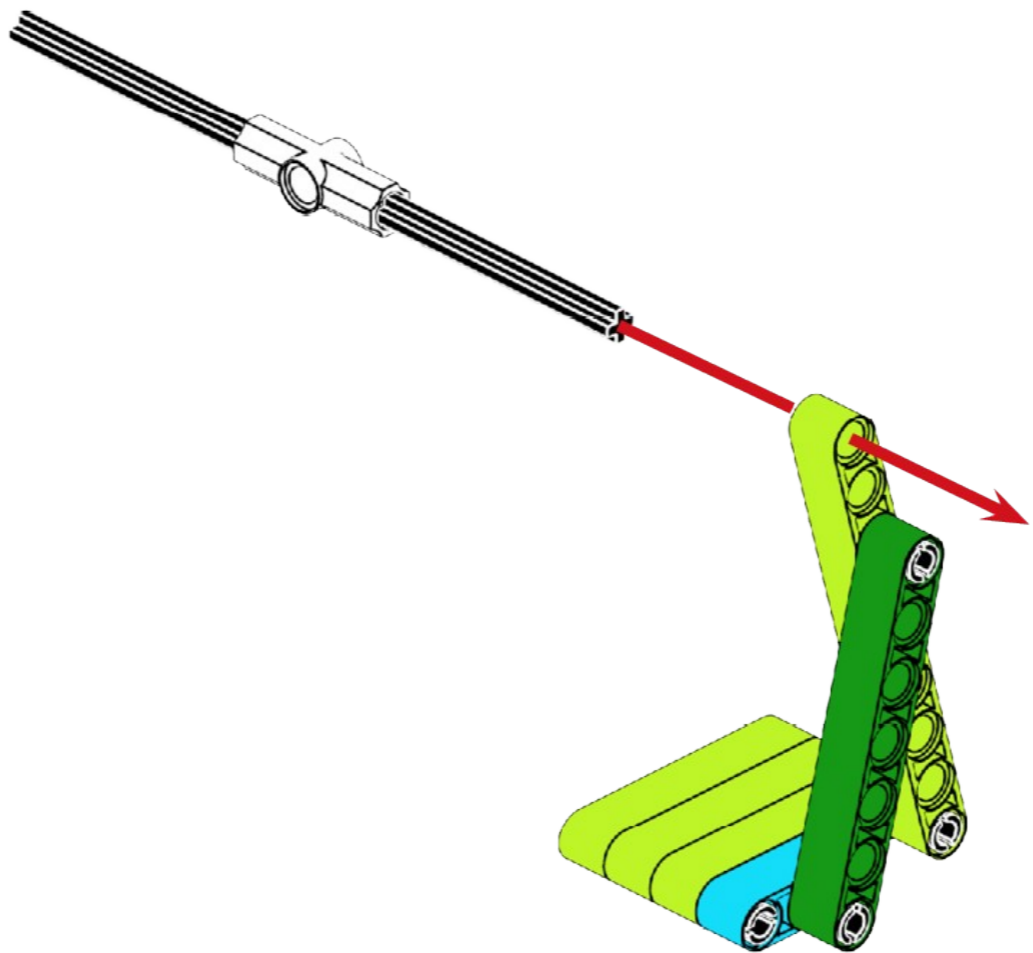

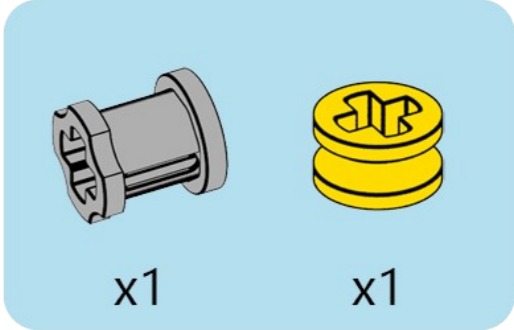
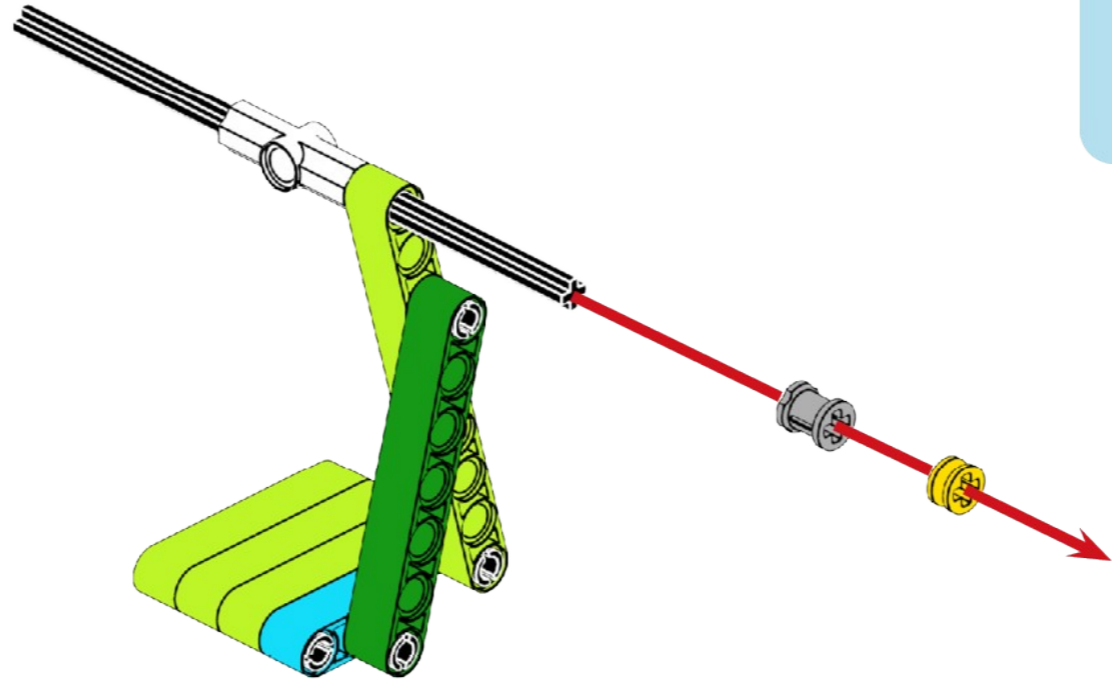
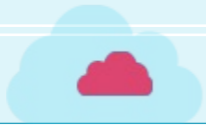

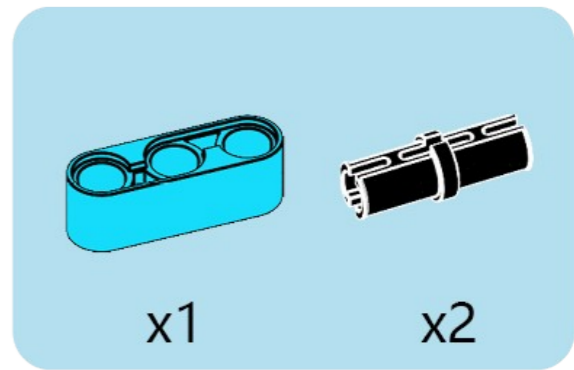
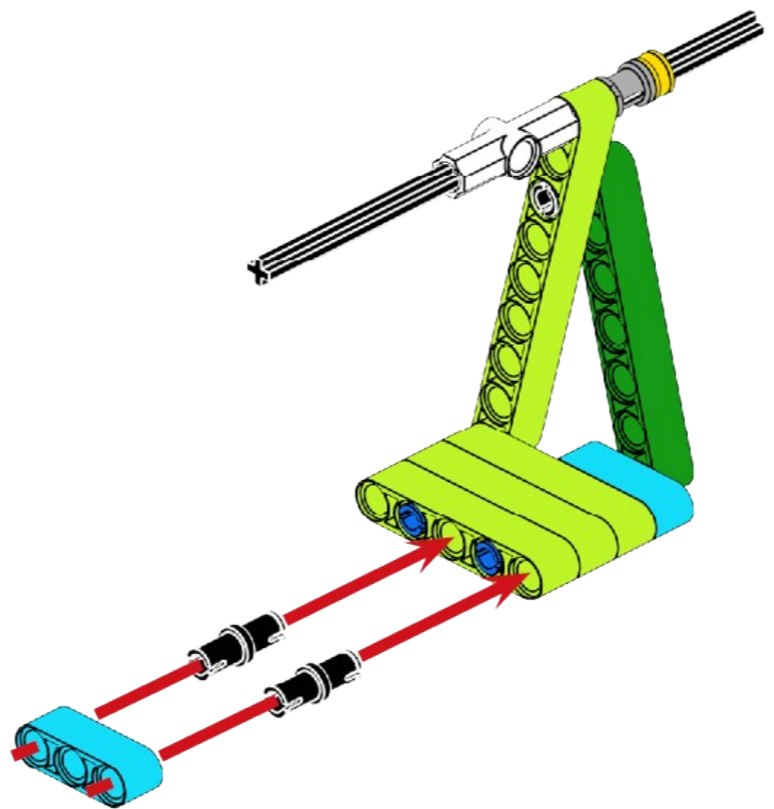

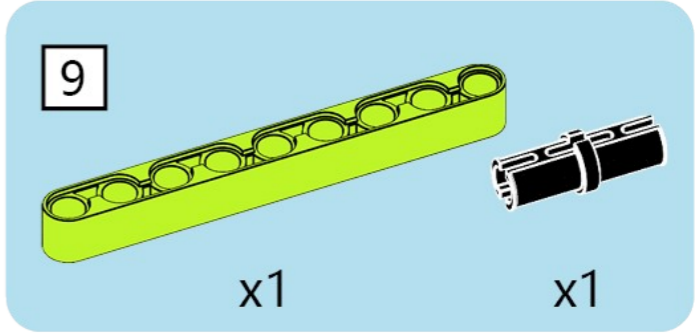
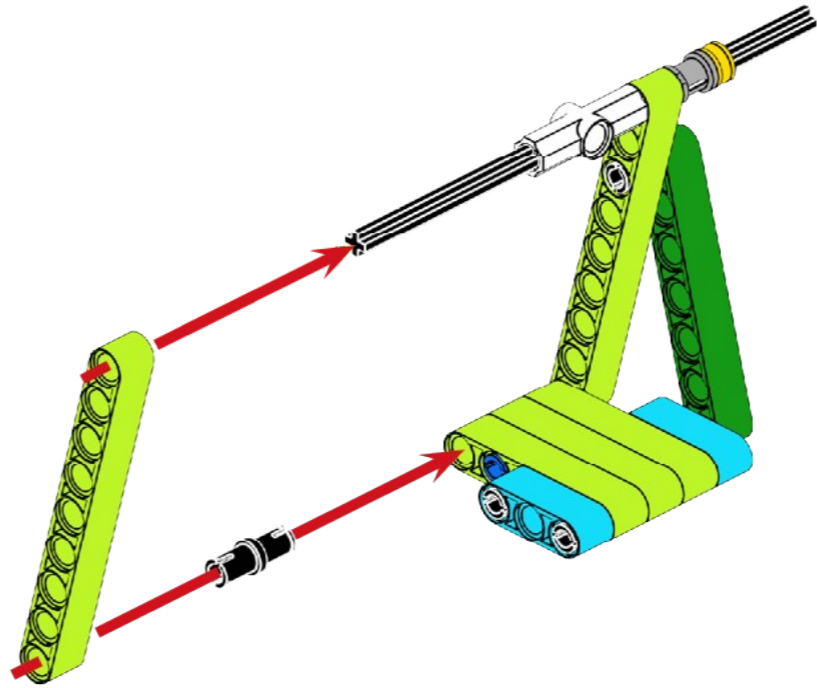
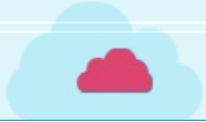

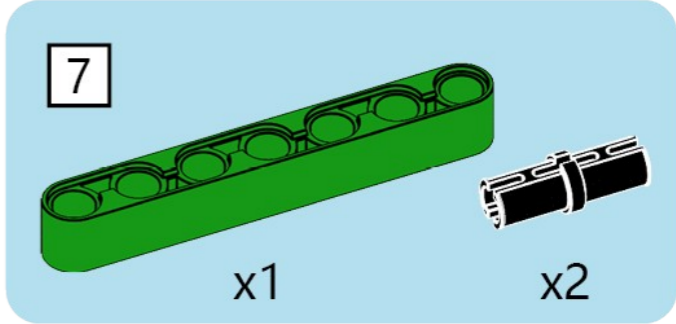
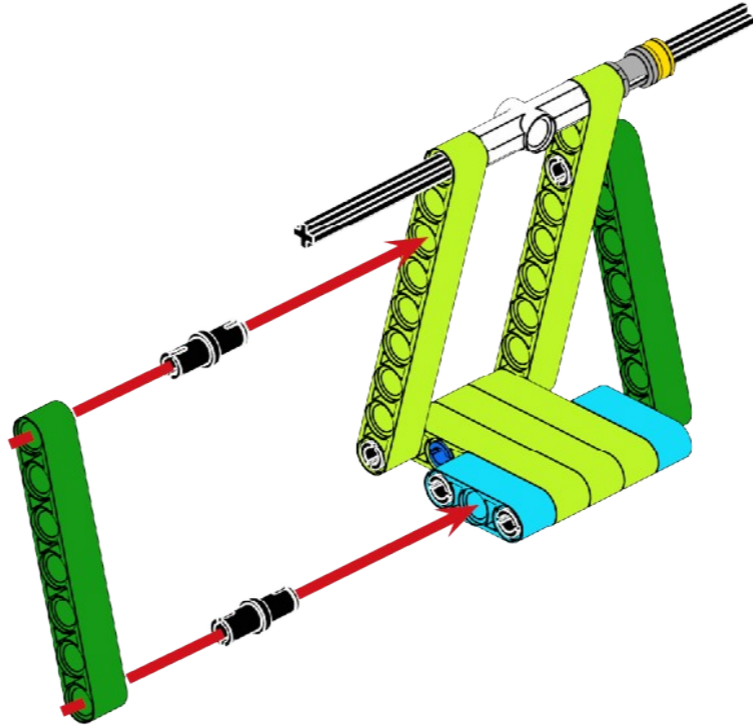

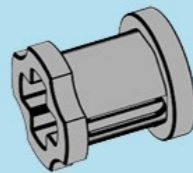
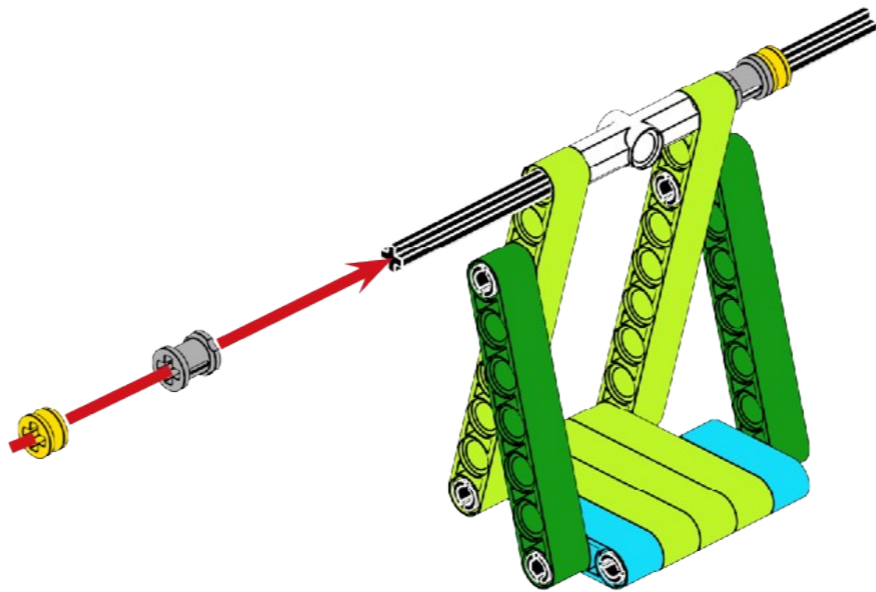

x1



x1

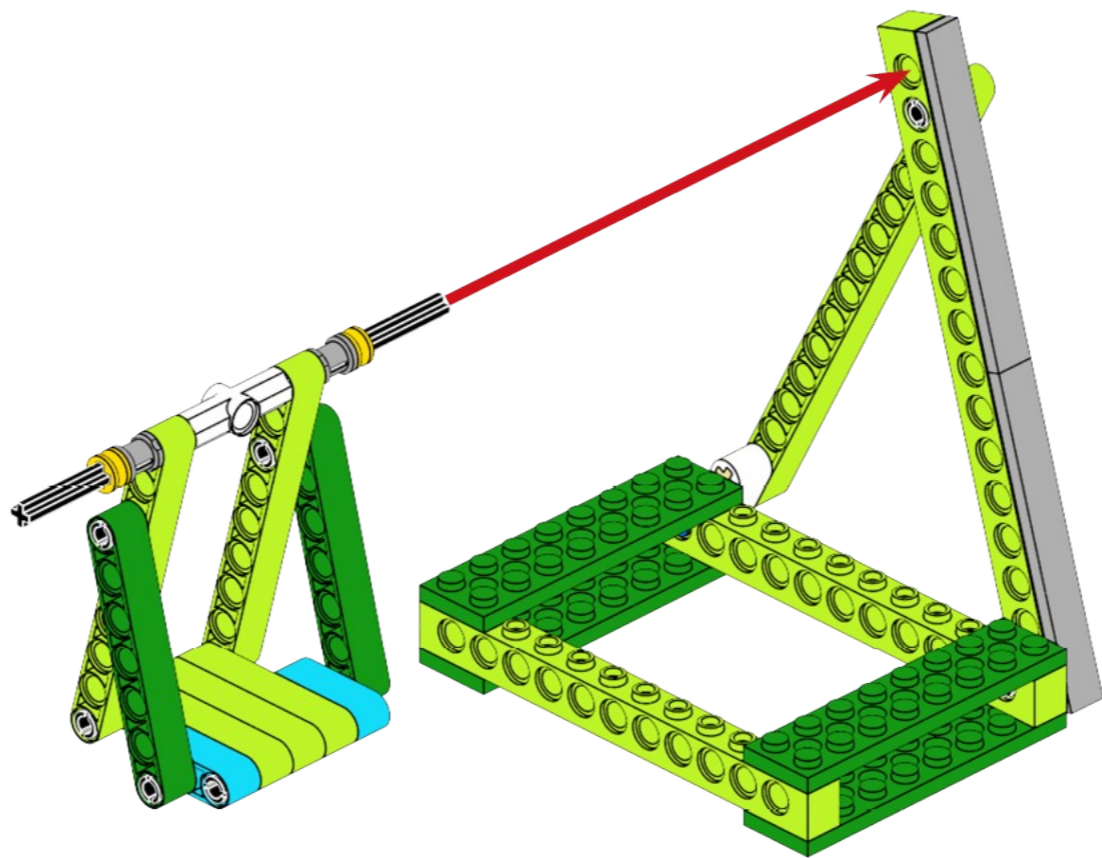

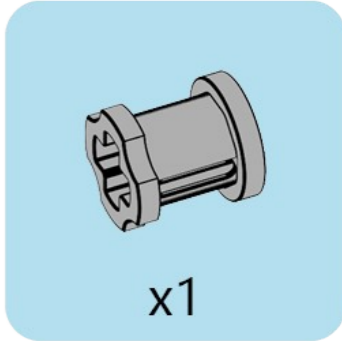
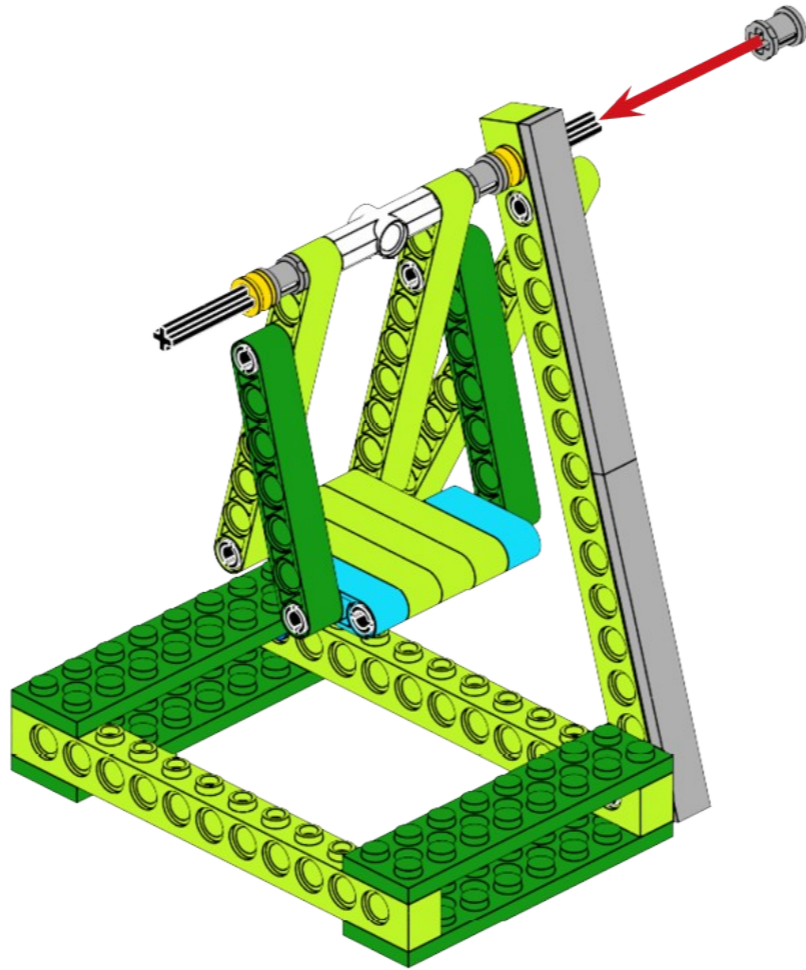



16

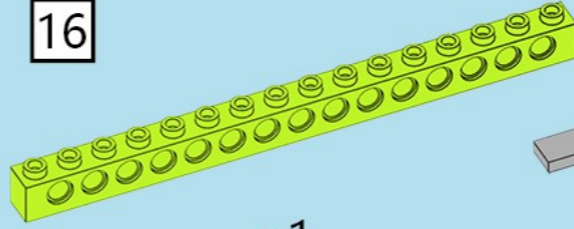

x1

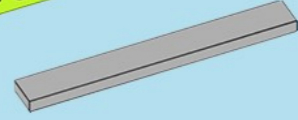

x2

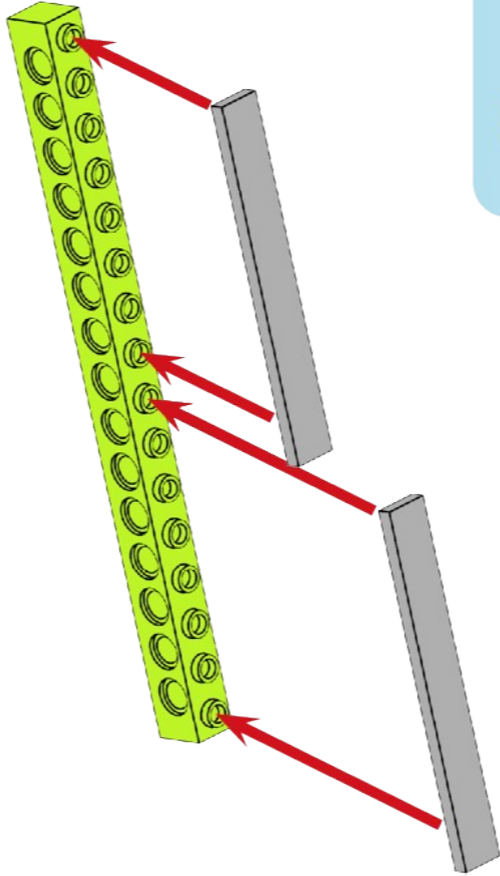

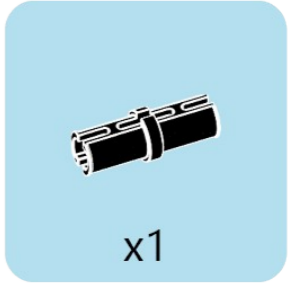
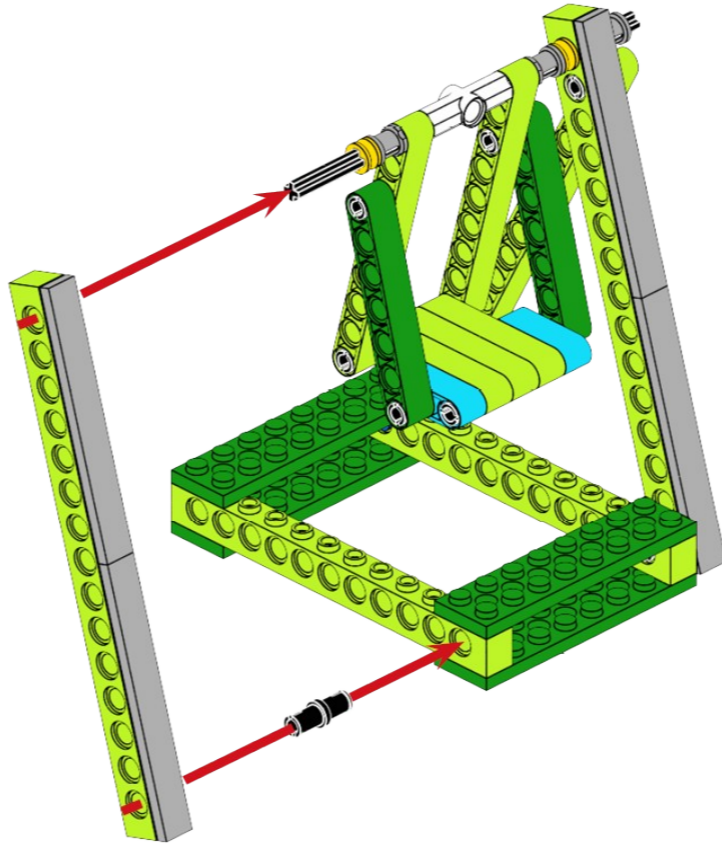
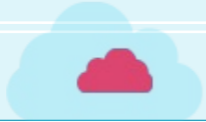

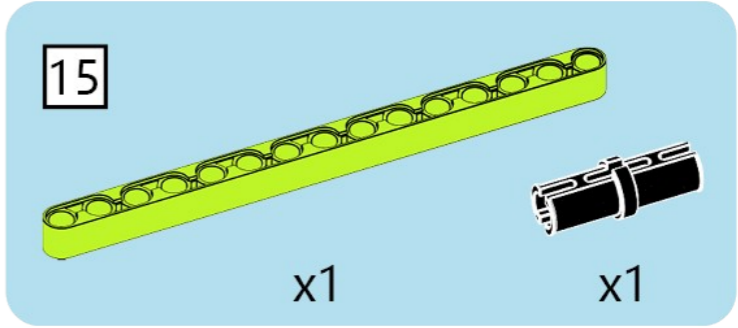
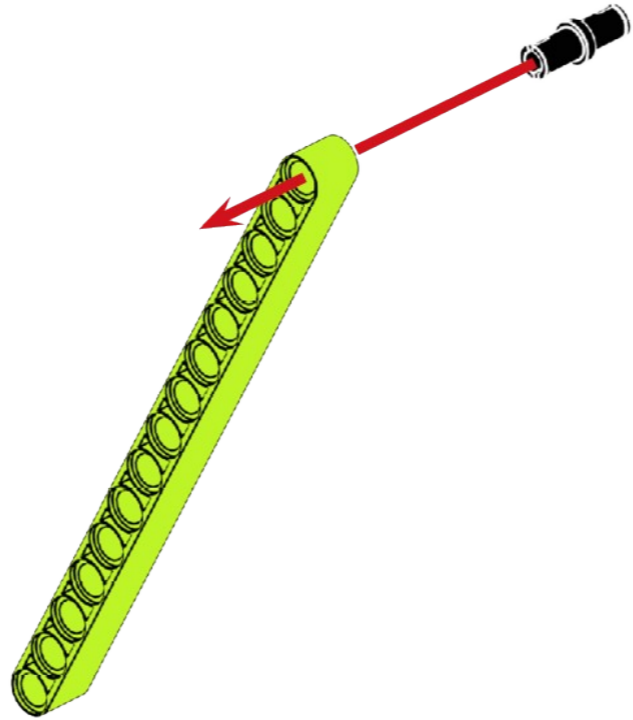
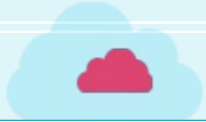

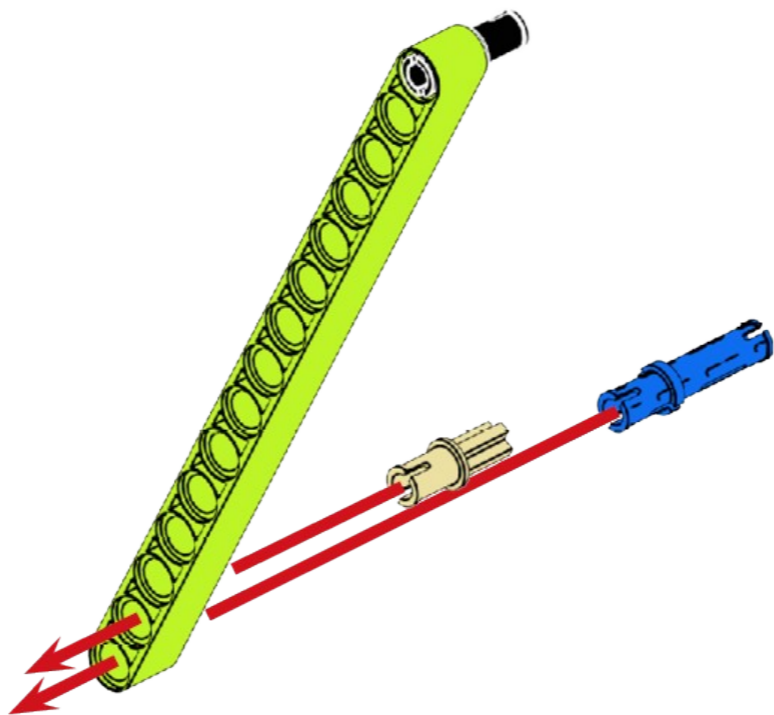

x1

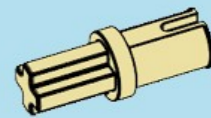

x1

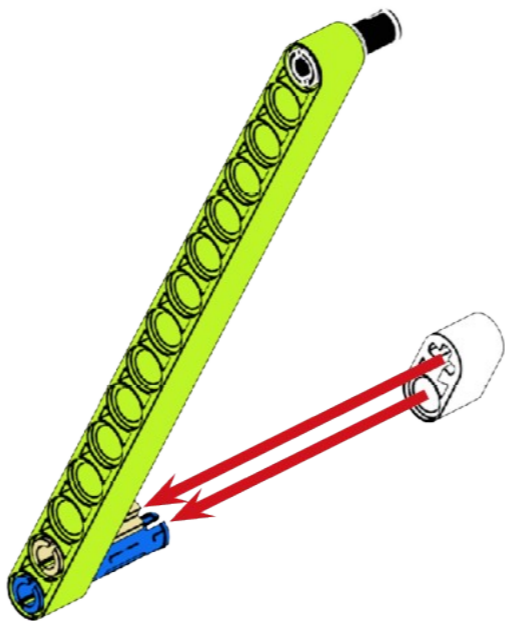
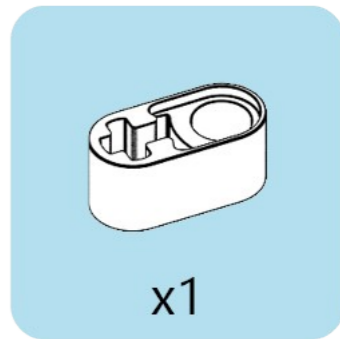

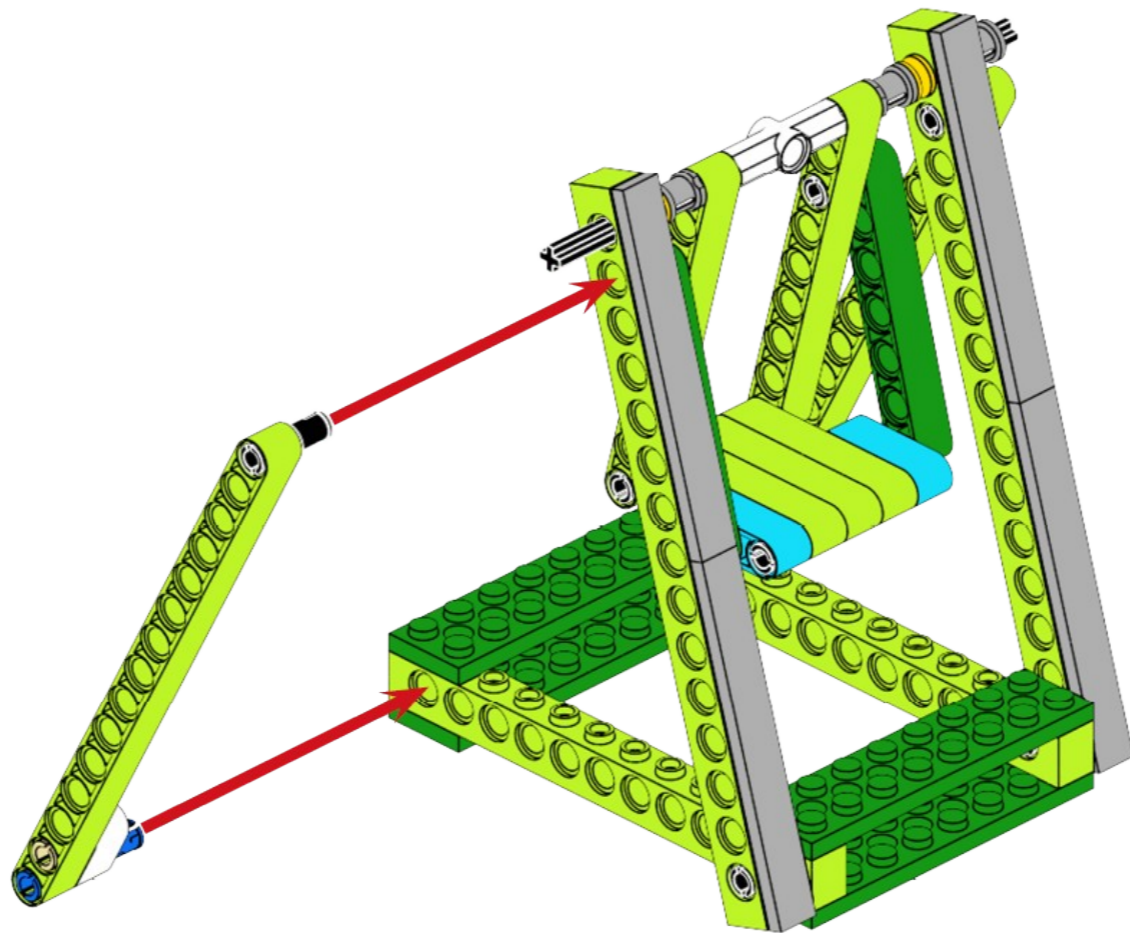

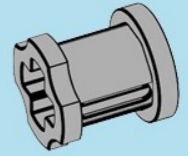
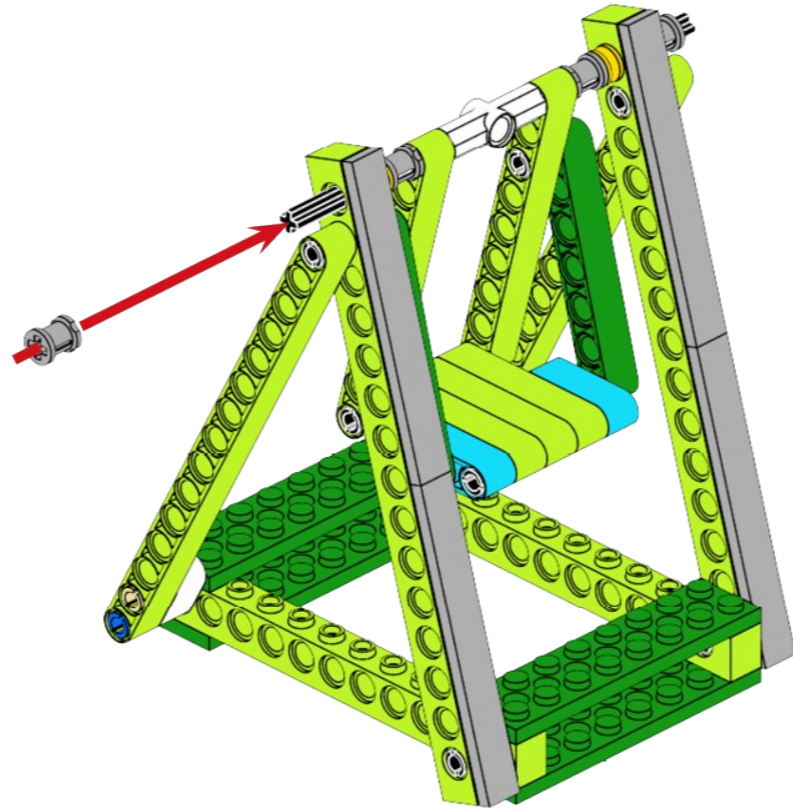
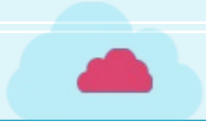

x1

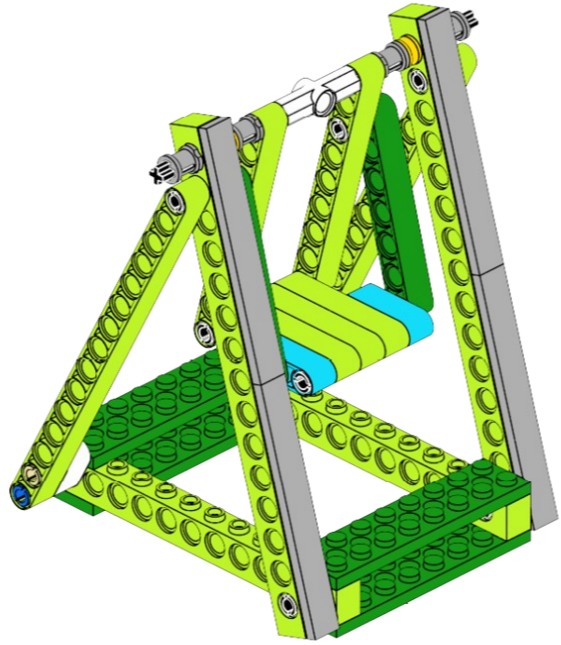

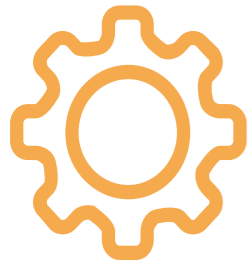
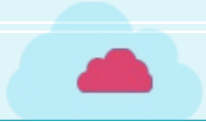

# Review

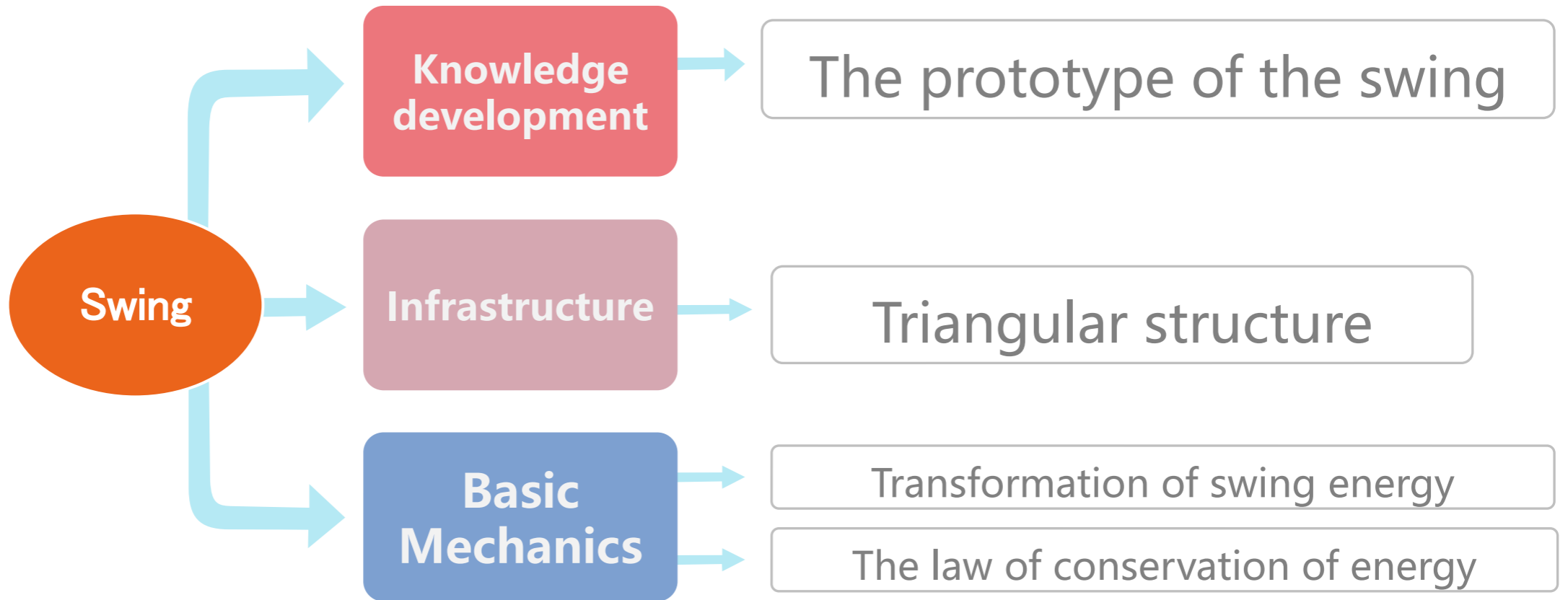



**Talk**

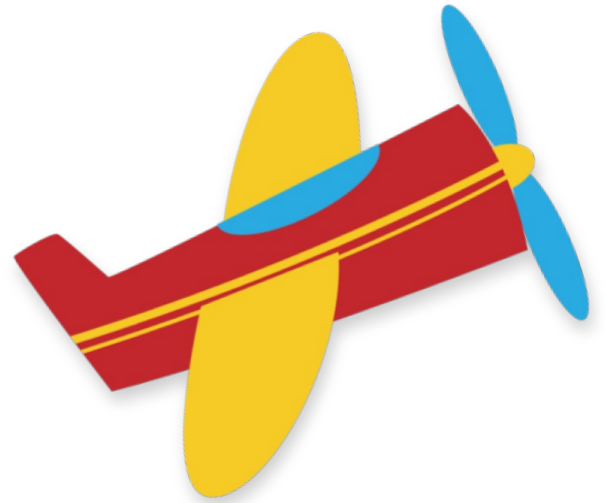



**THANKS**

