



Logic

Space



Coding



Focus

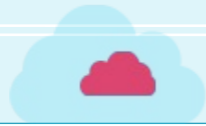

Classroom Discipline

01

Please sit down and keep quiet in class.

02

Please raise your hand if you have any questions

03

Please observe carefully when the pictures are played.



The Air Rescue

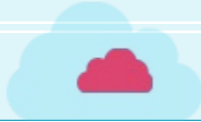



Think

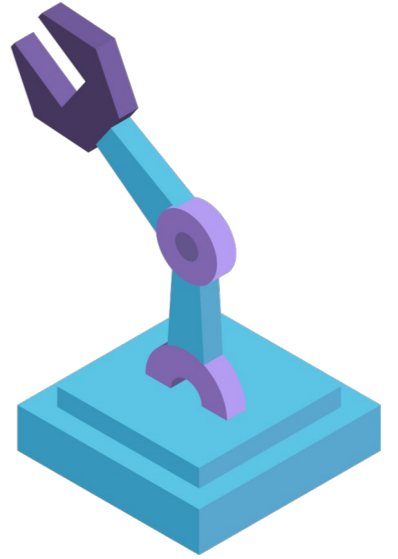

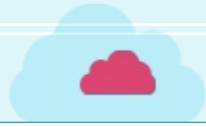

1. Kids, what can we use for rescue after a natural disaster?
2. What should we do after a natural disaster?





Explore

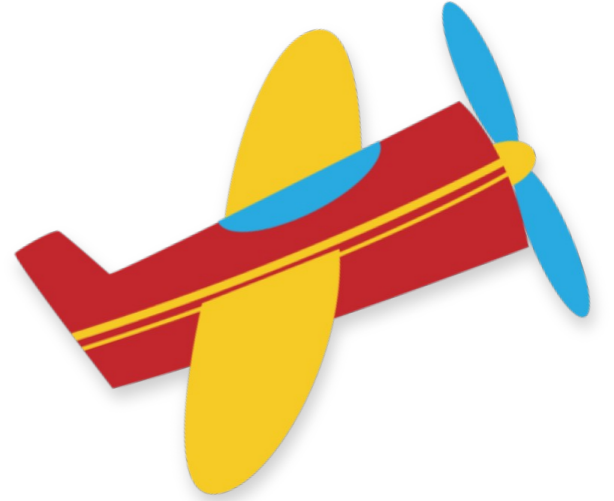

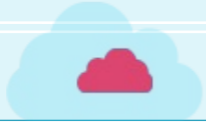

1. Who invented the airplane?

2. Which animal's characteristics were used as a reference for the invention of the airplane?

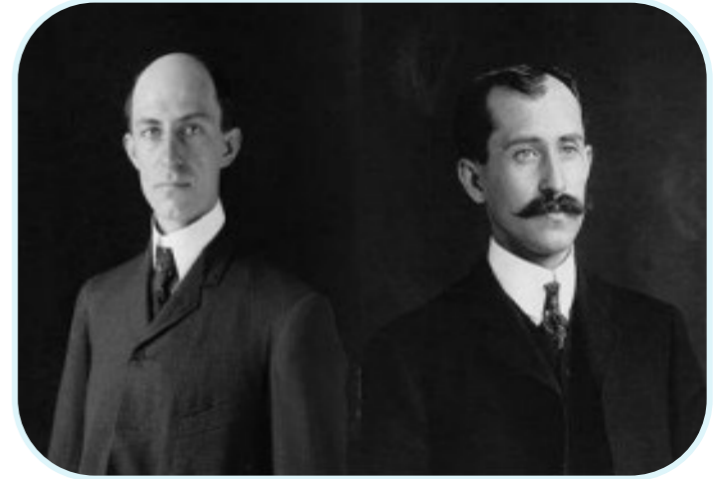

Wright Brothers





Build

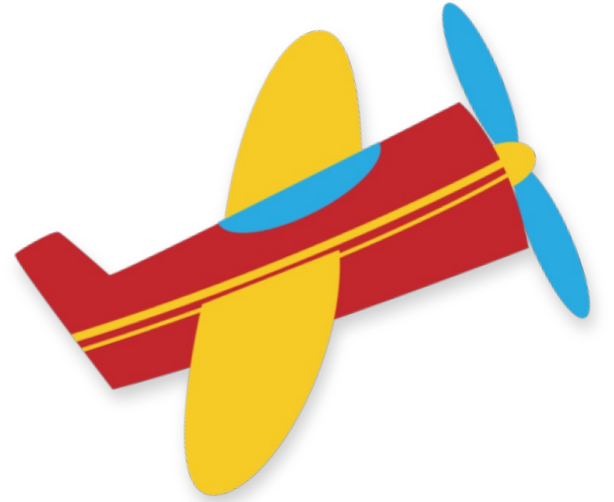

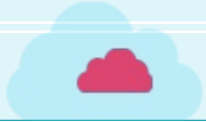

Rear



Propeller

landing gear

Cabin (driver's cabin)

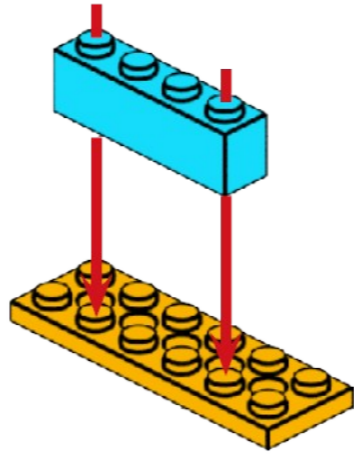
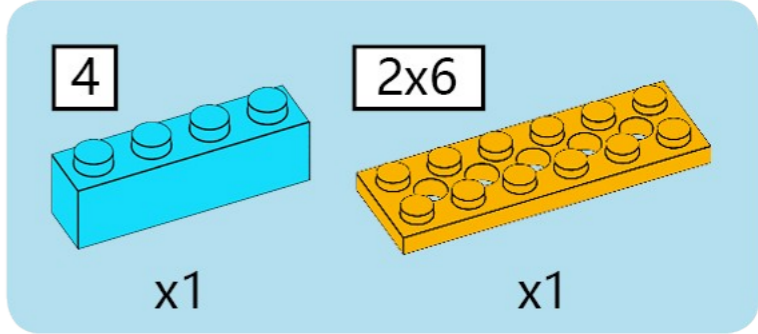

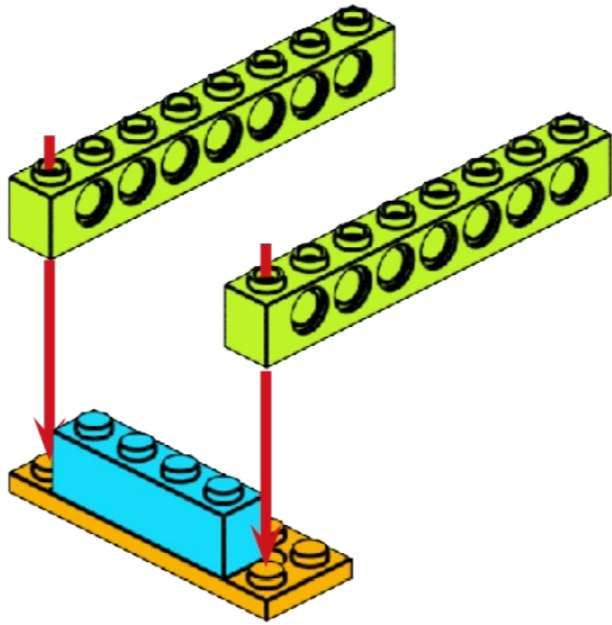

8

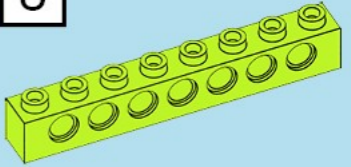

x2

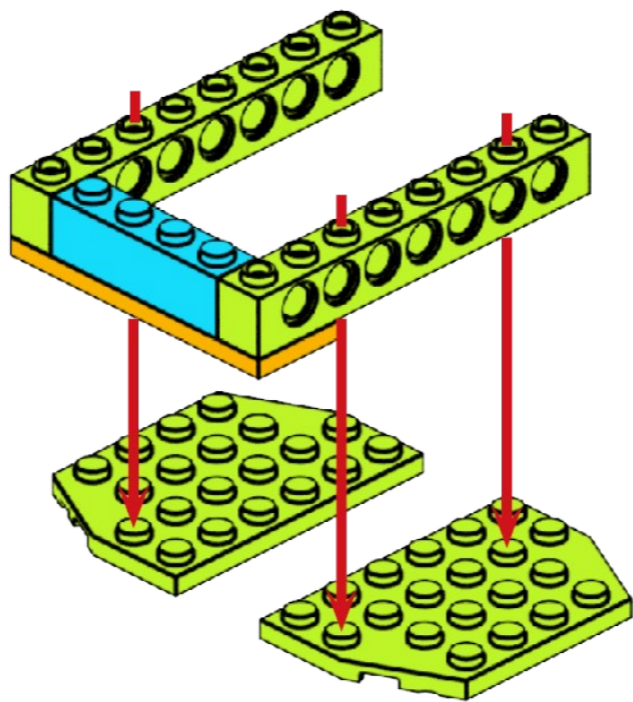
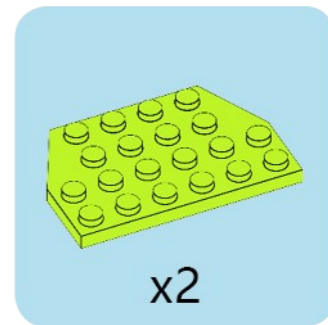



12

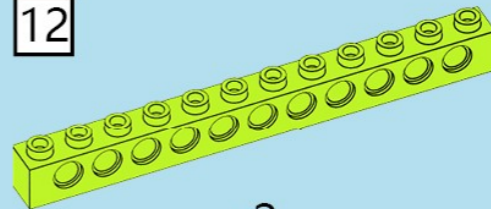

x2

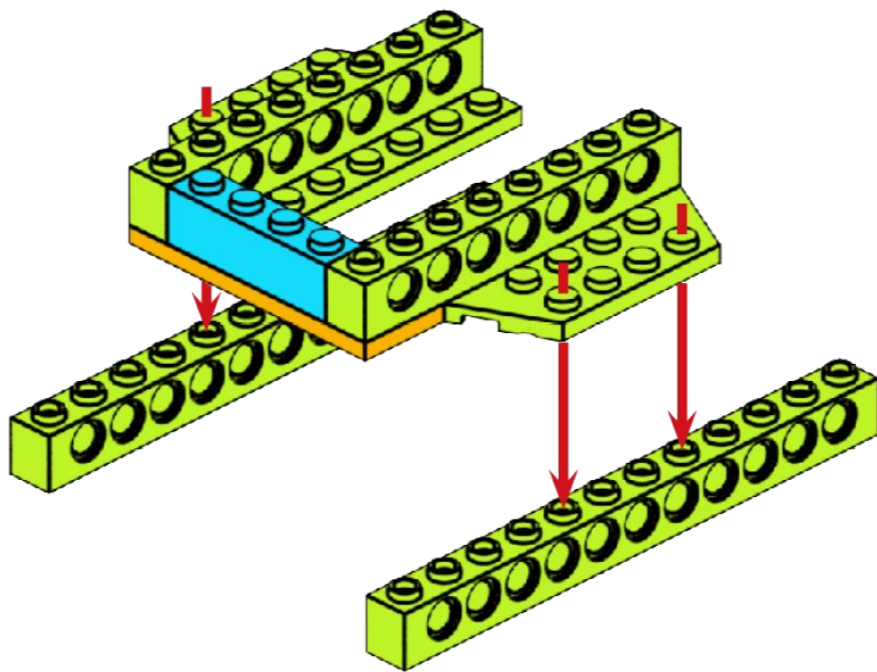

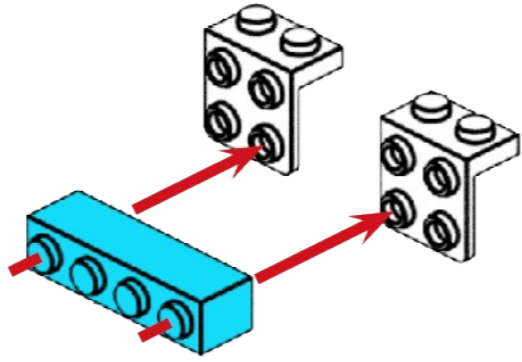
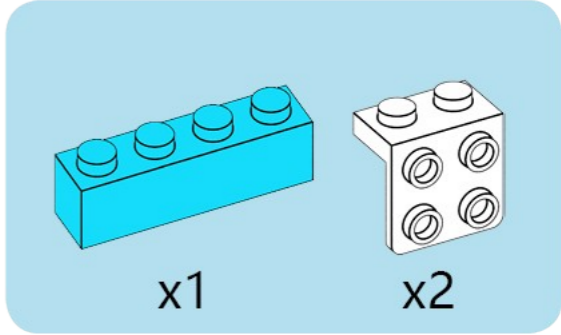

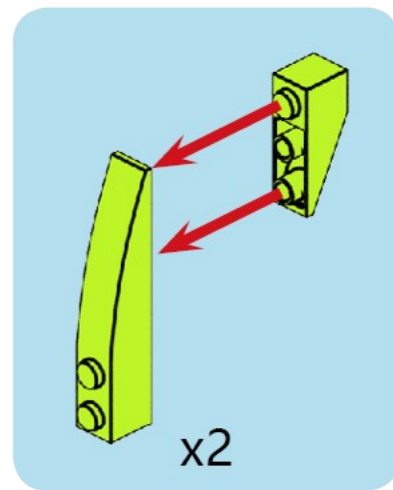
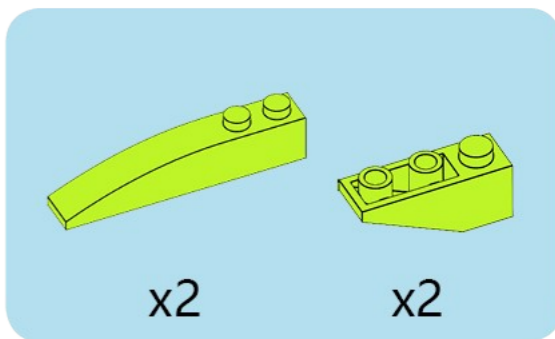
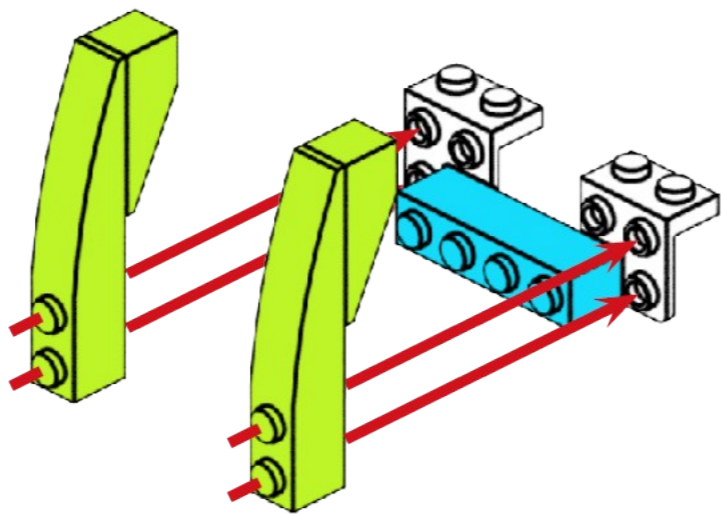

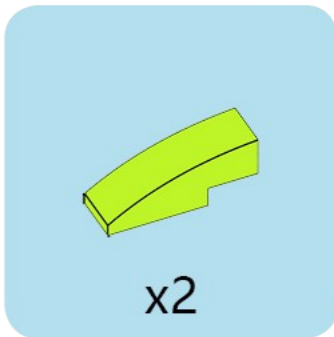
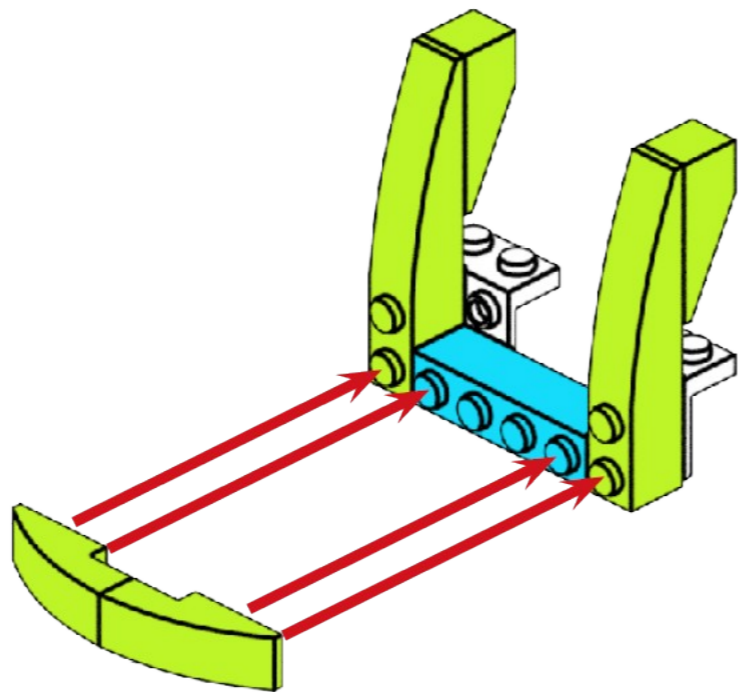

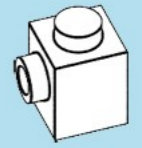

x2

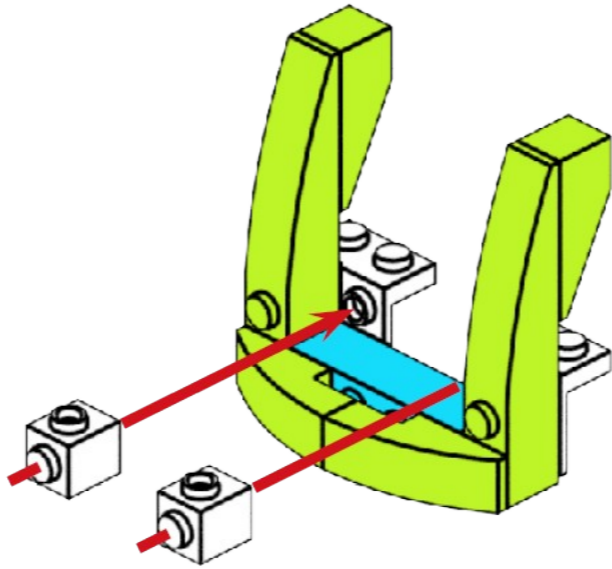

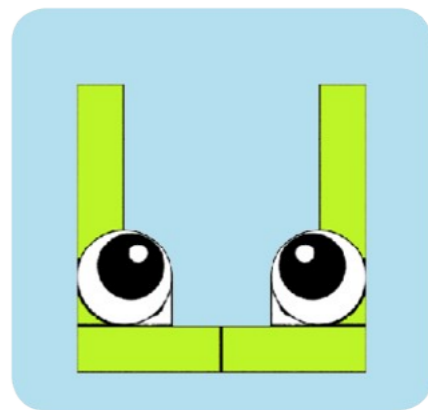
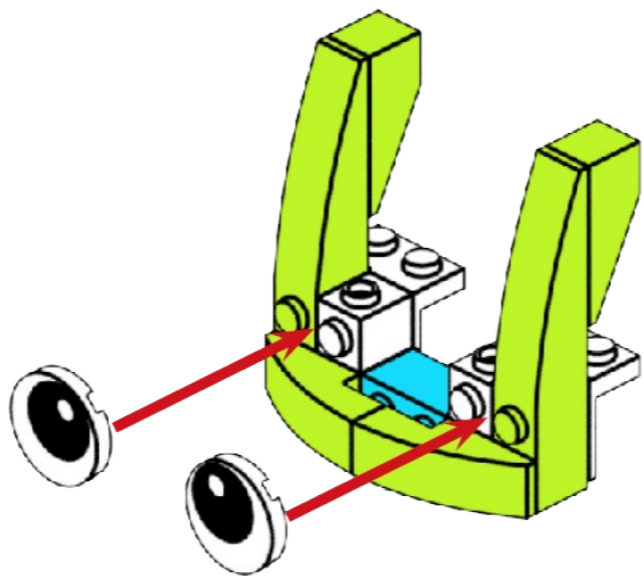
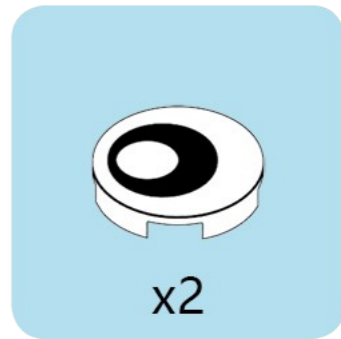

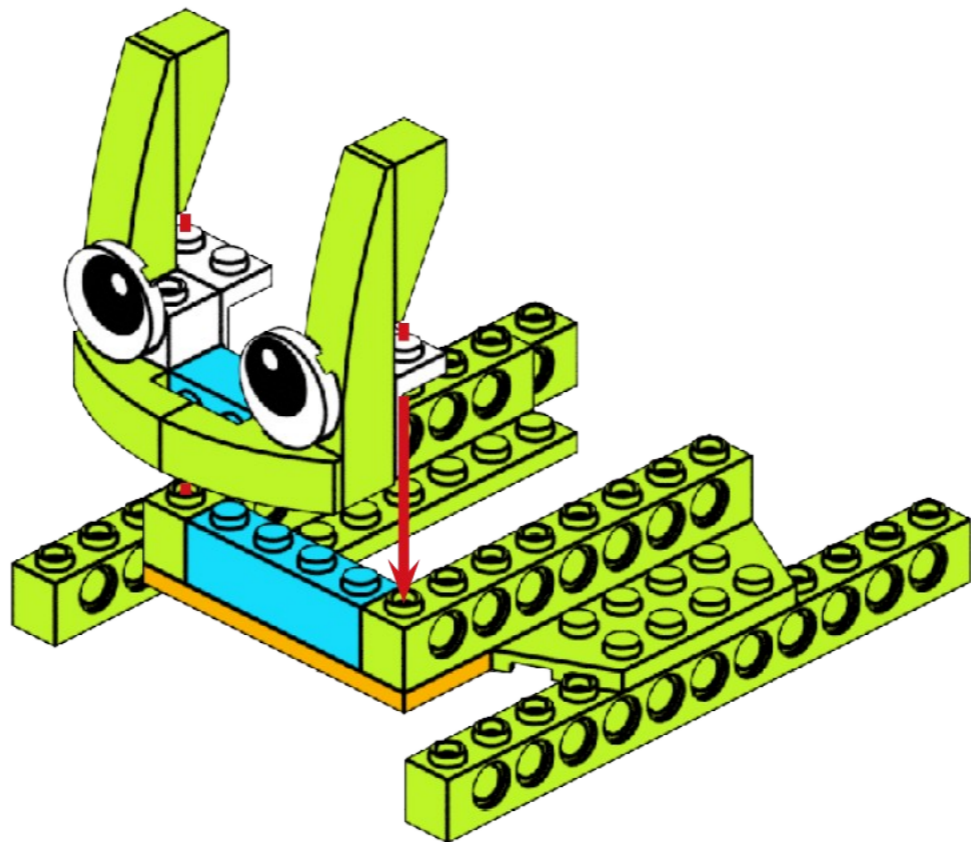

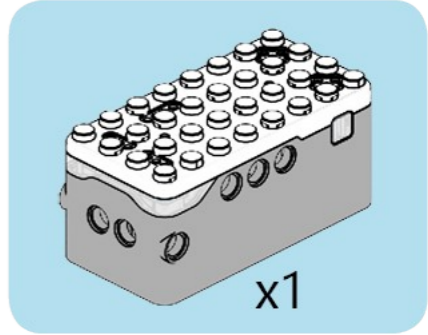
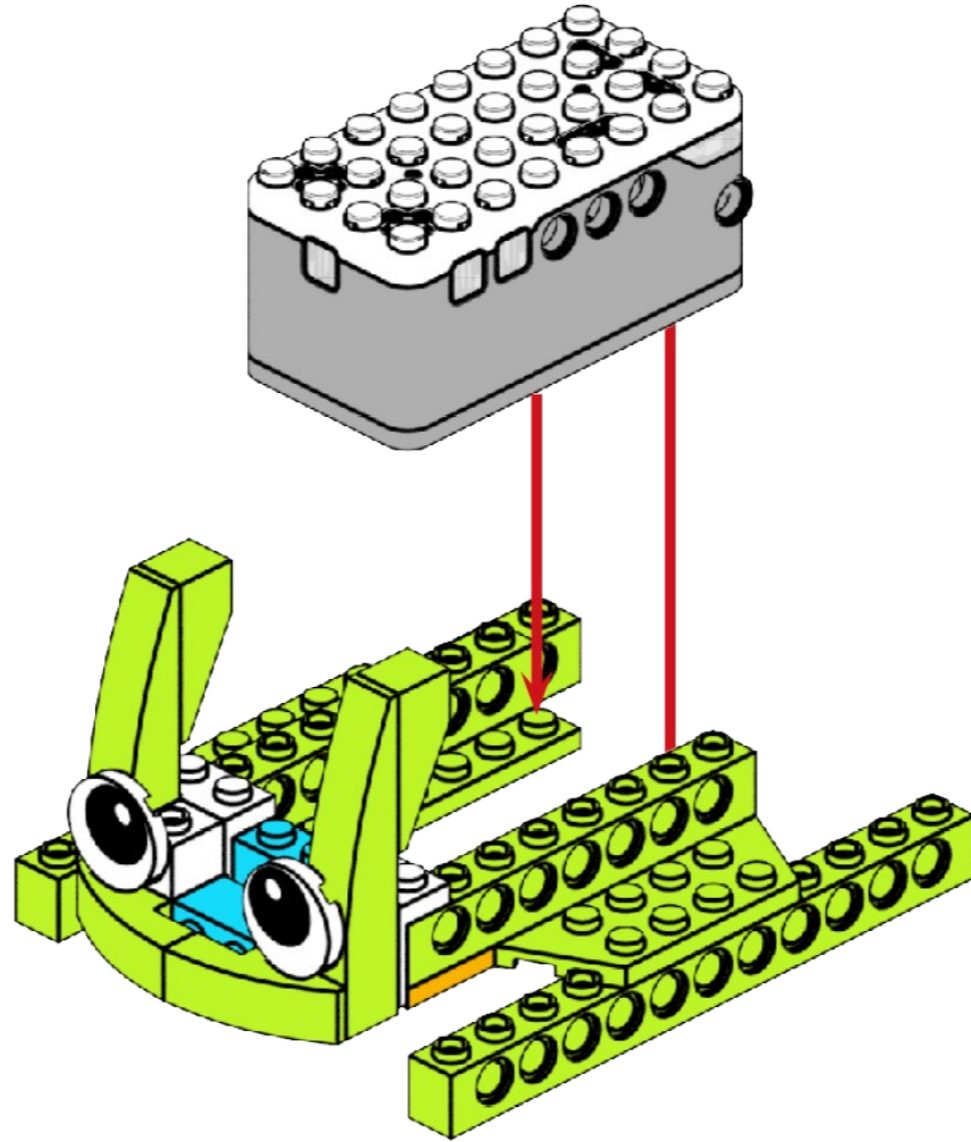

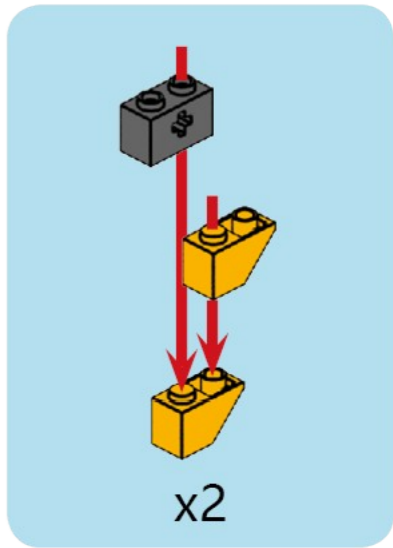
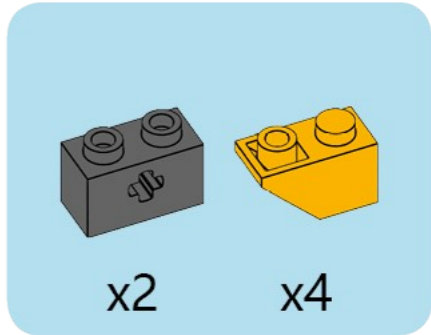
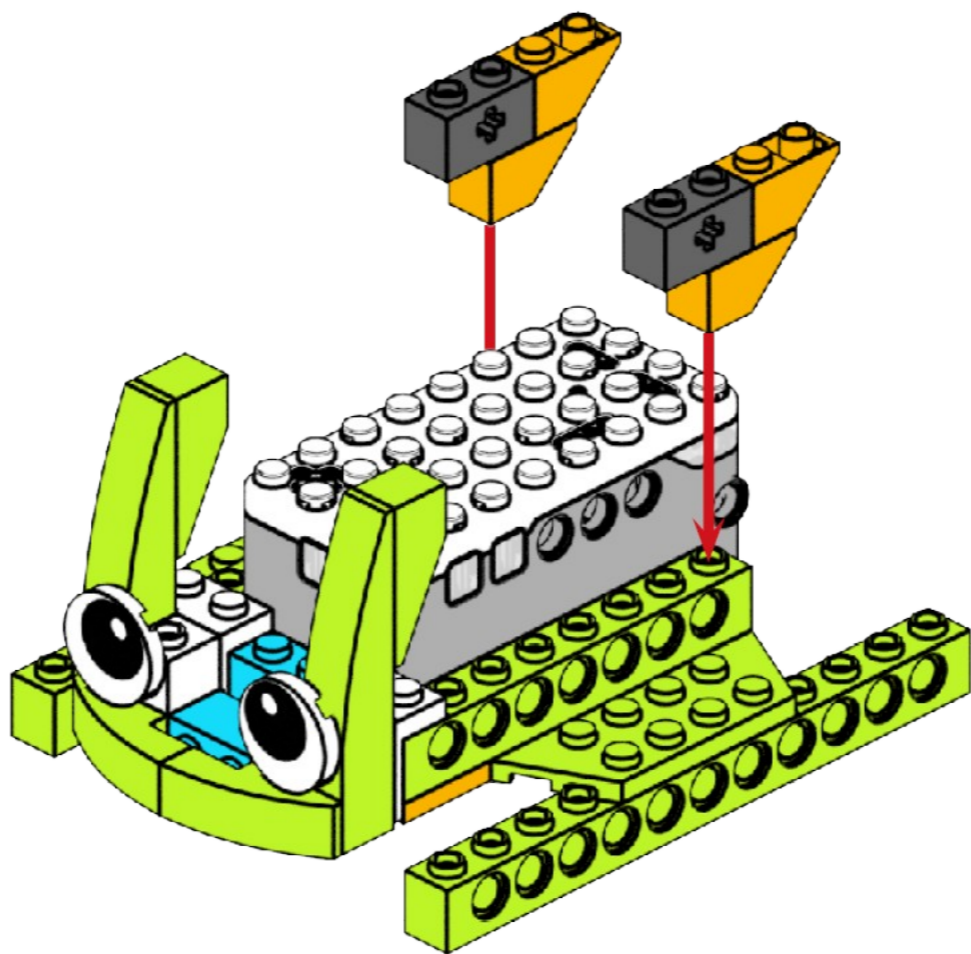

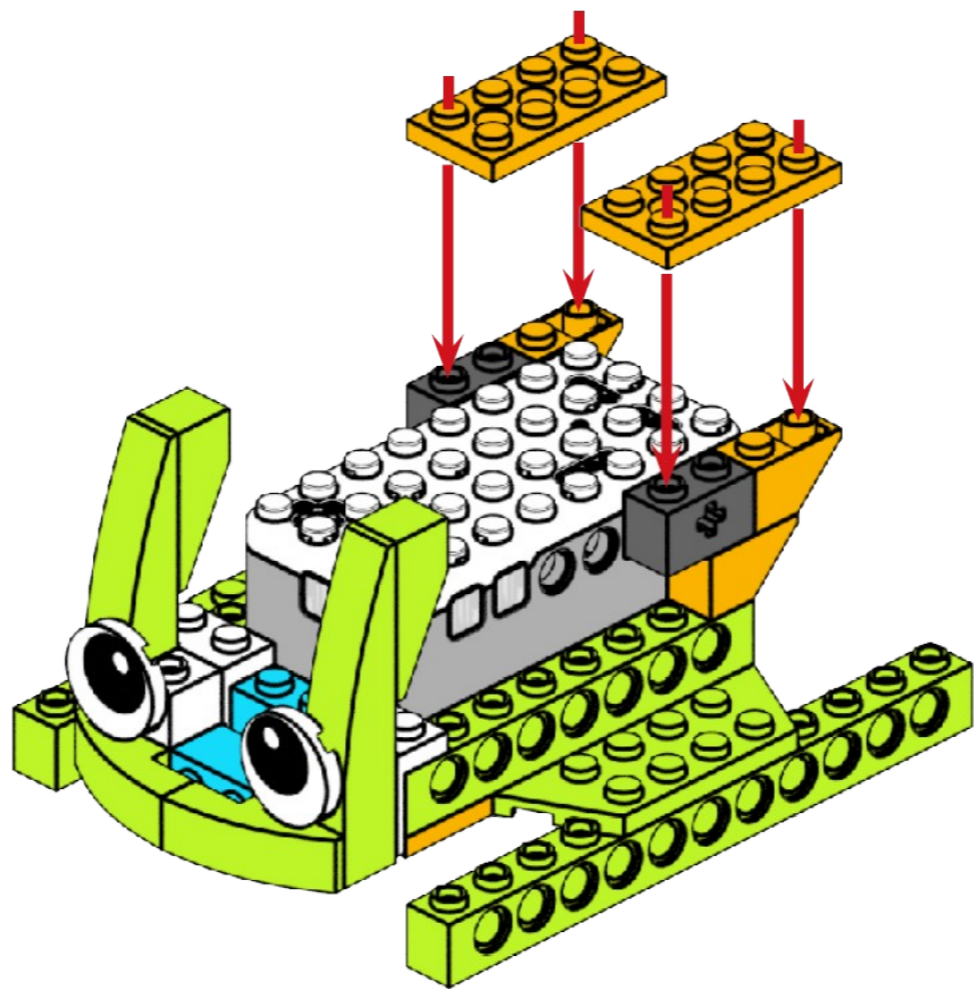

2x4



x2

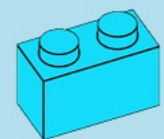
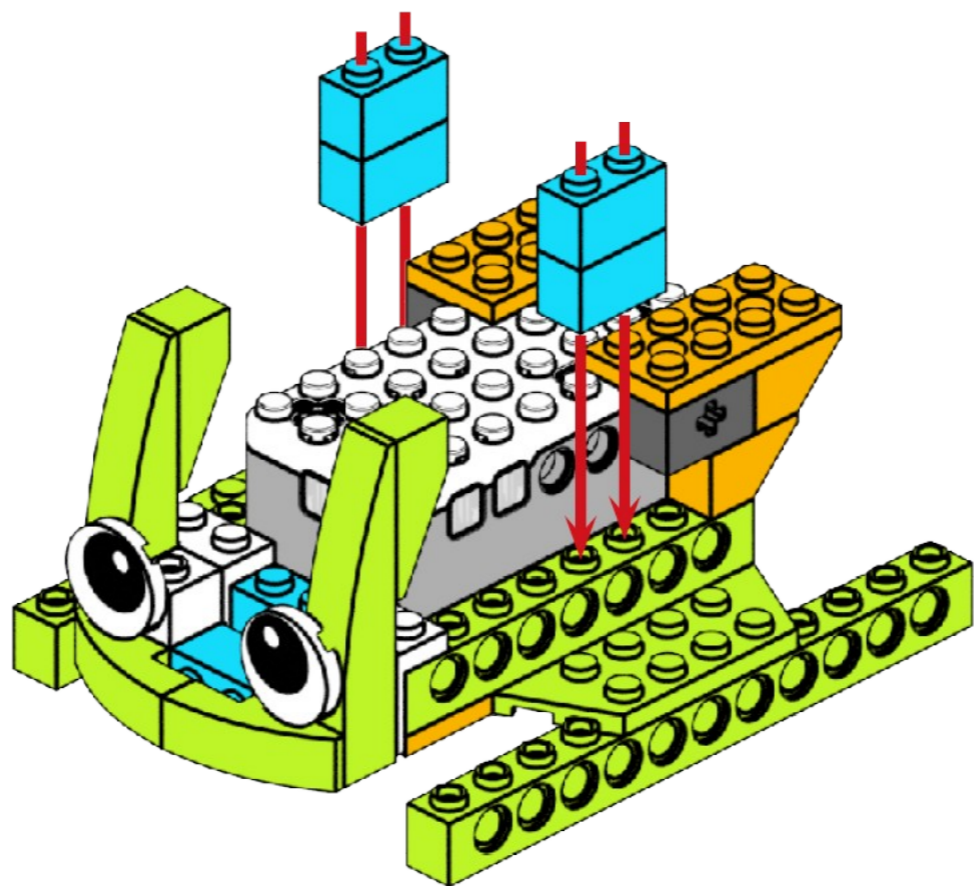

x4

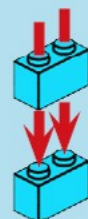

x2

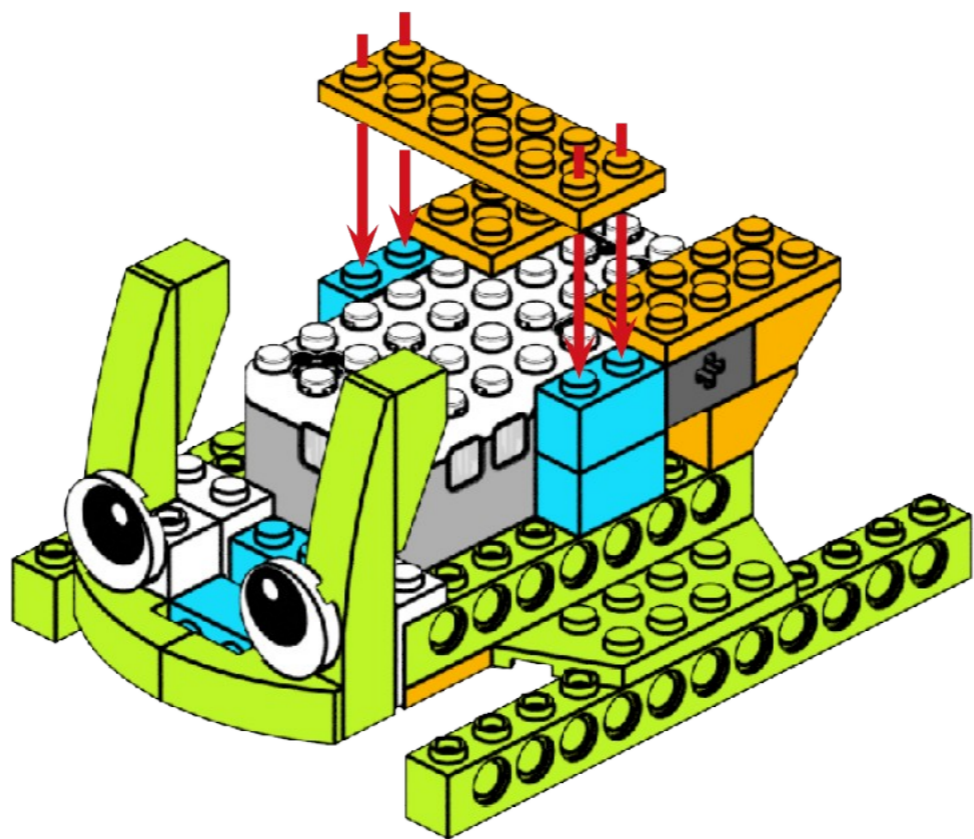
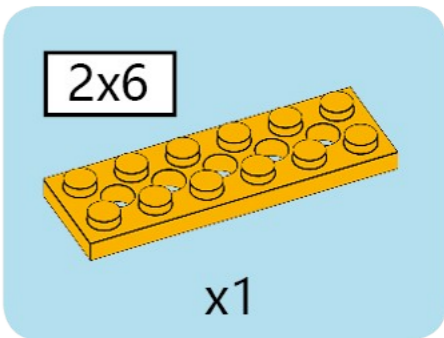

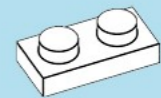
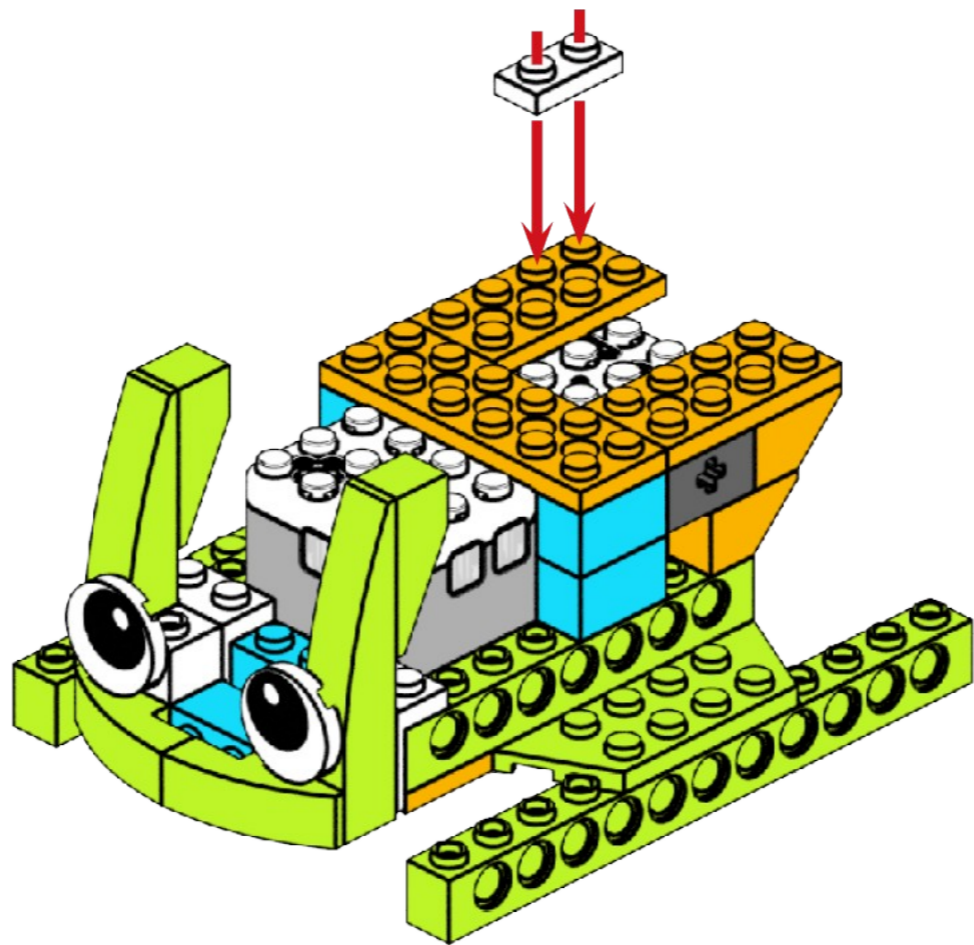

x1

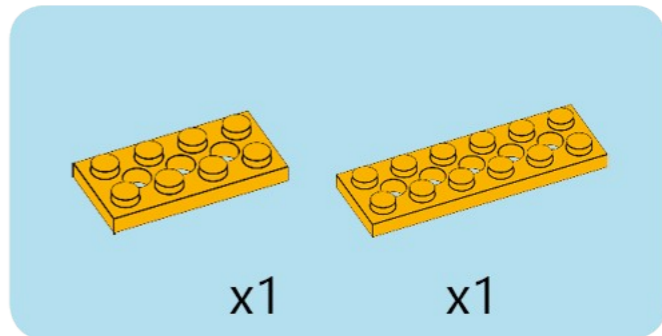
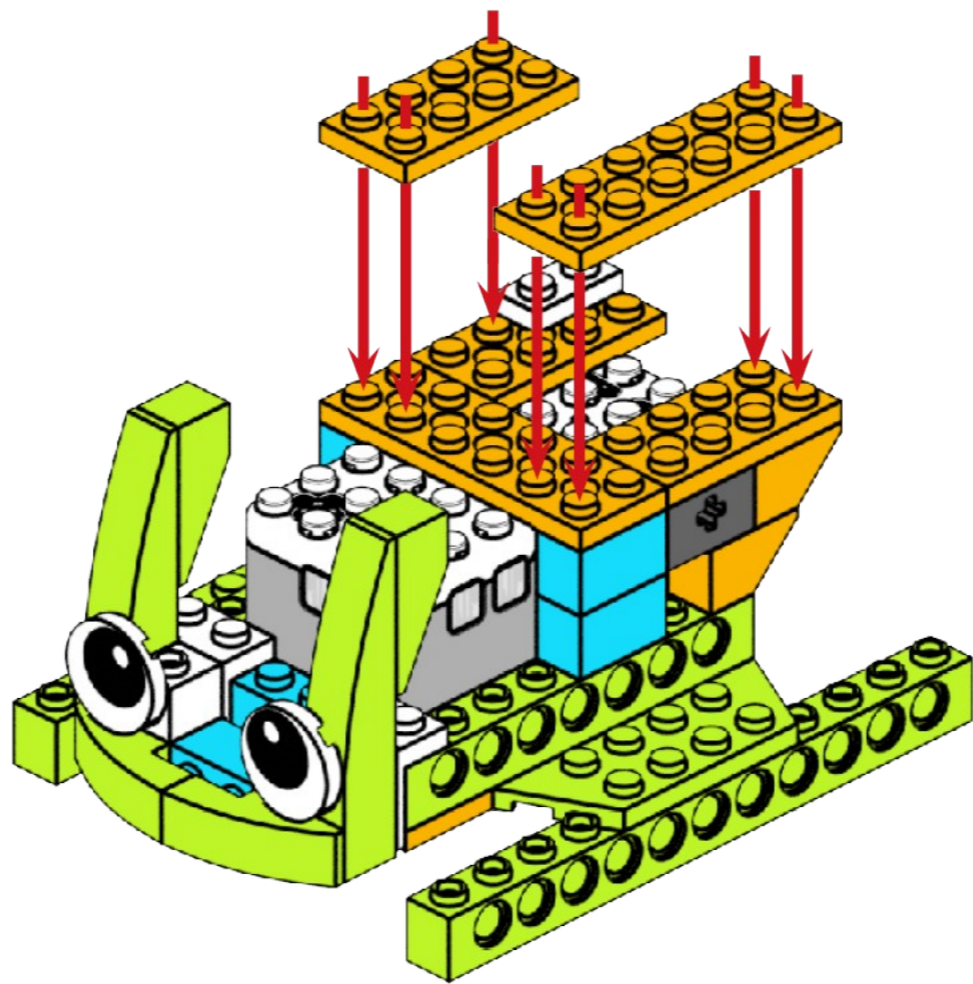

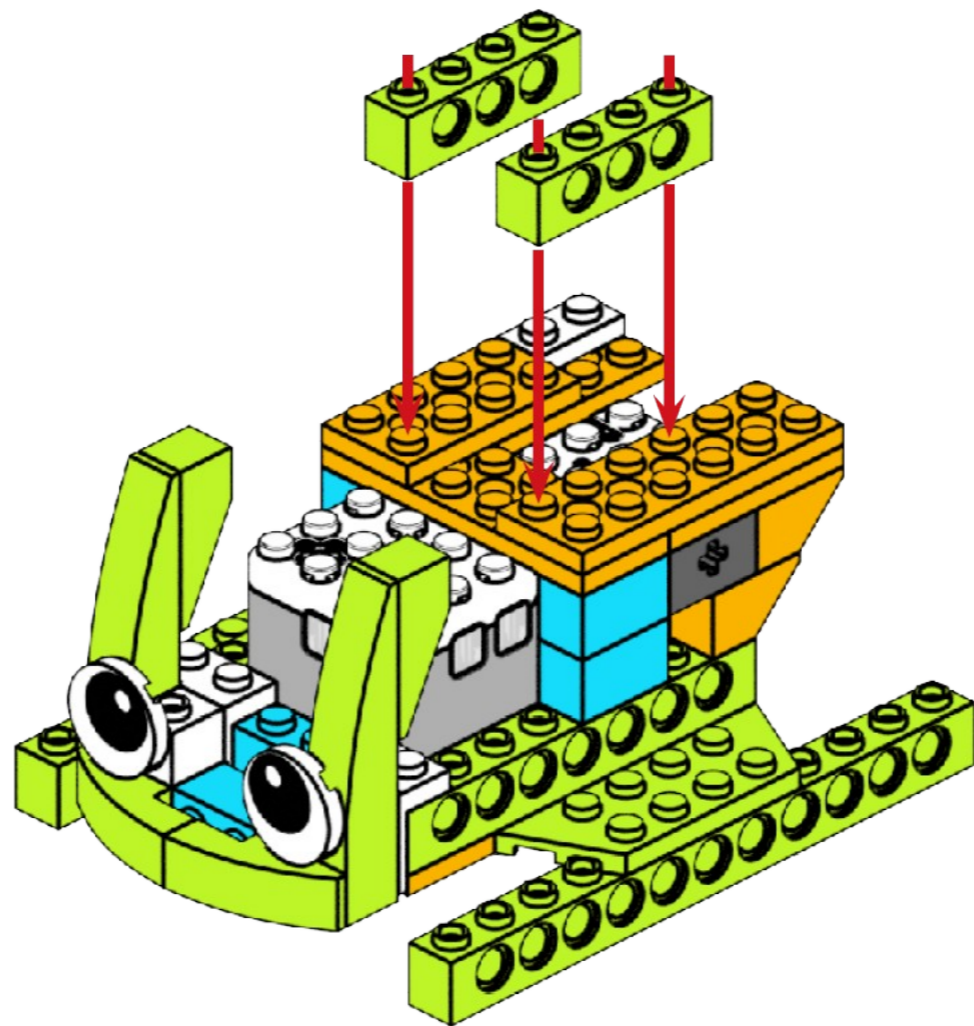

4

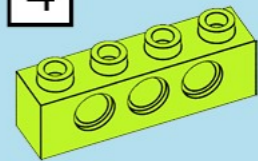

x2

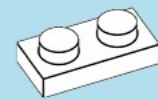
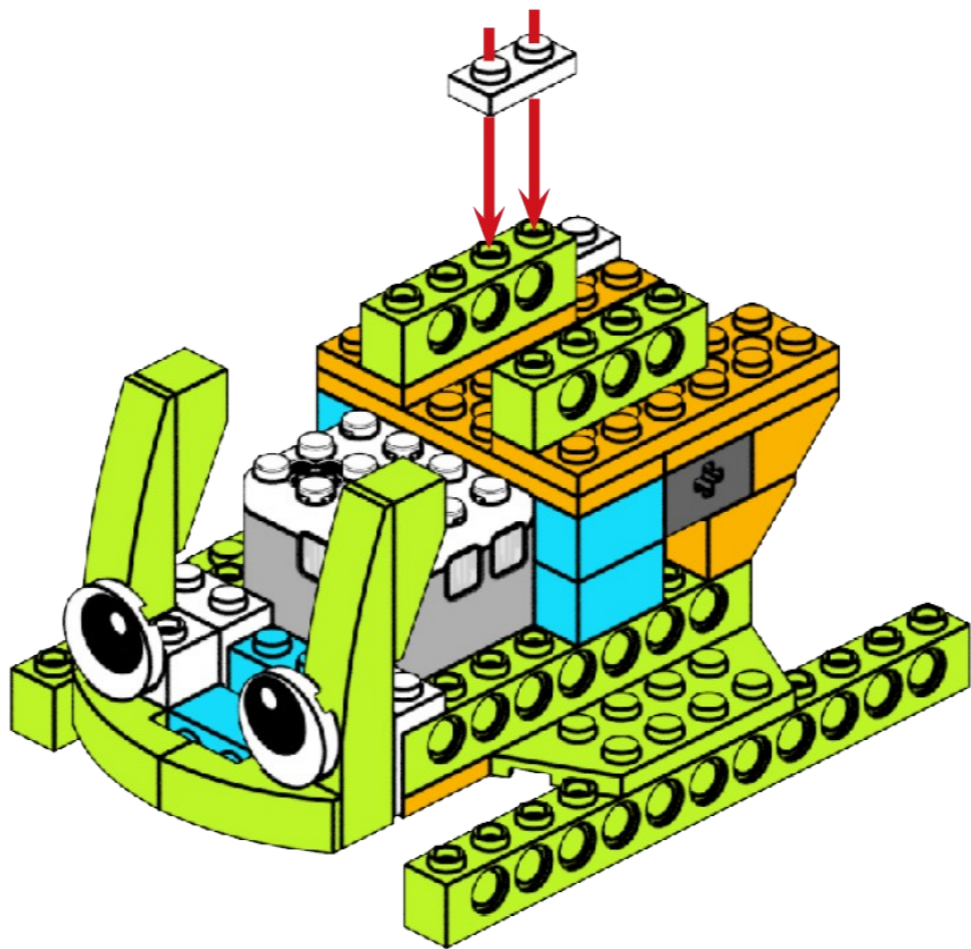

x1

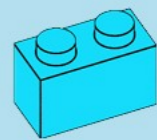
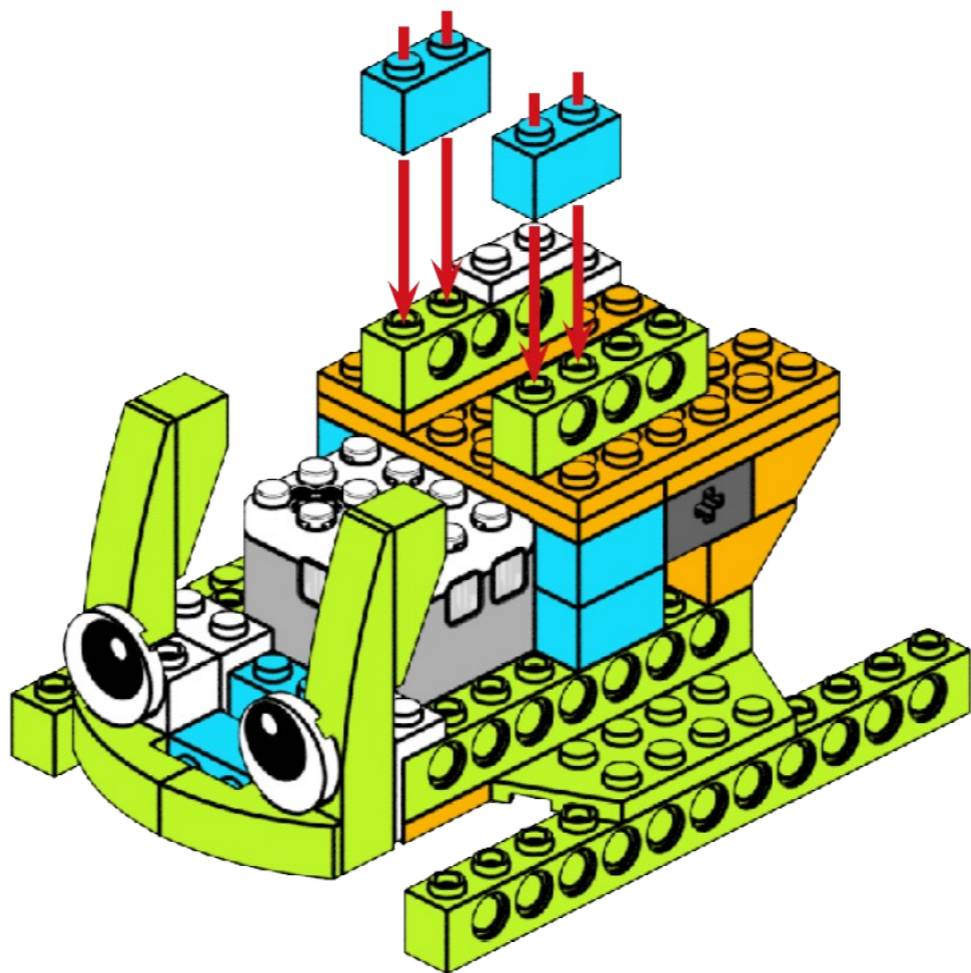

x2

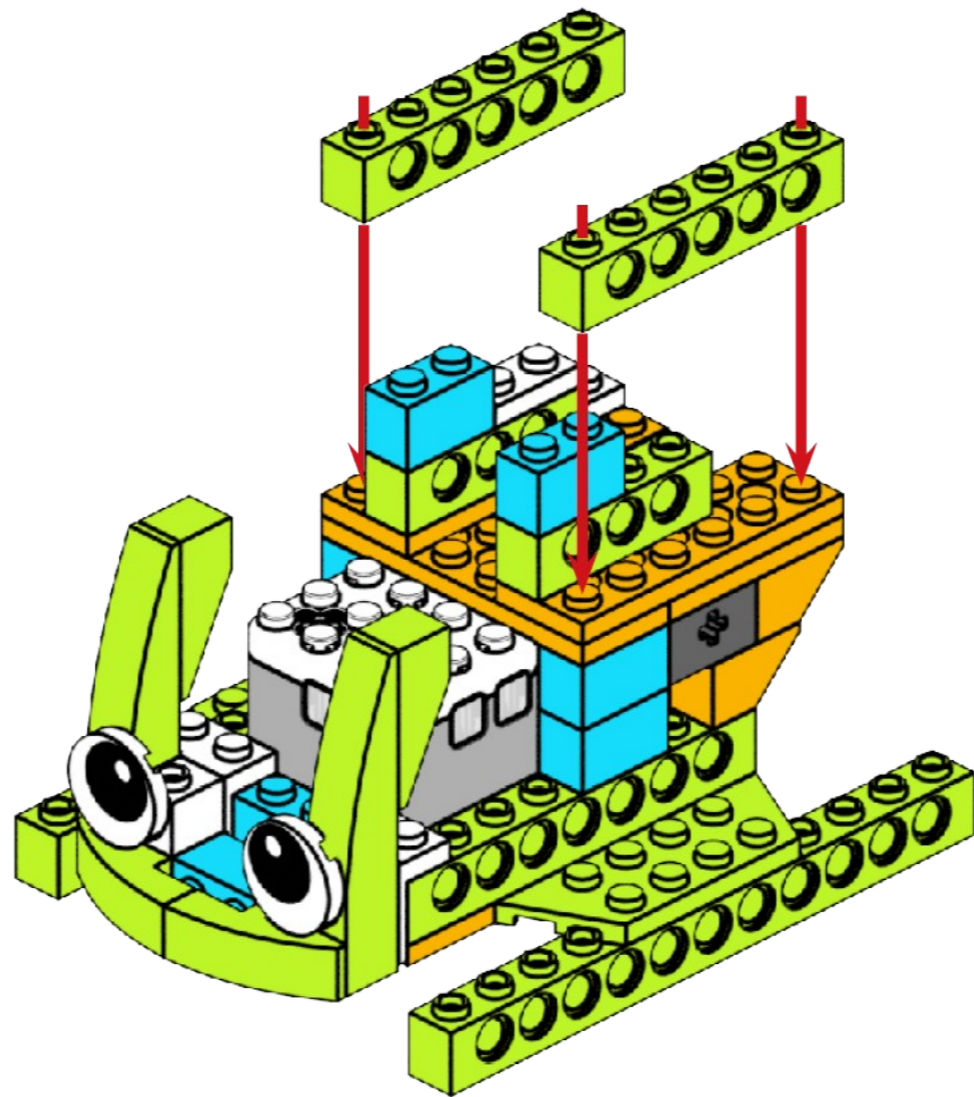

6

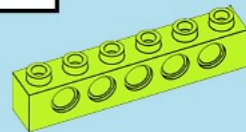

x2

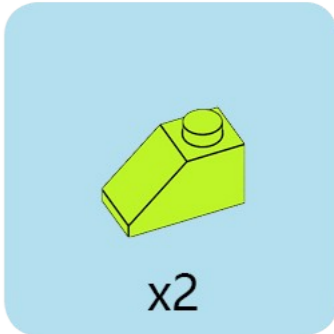
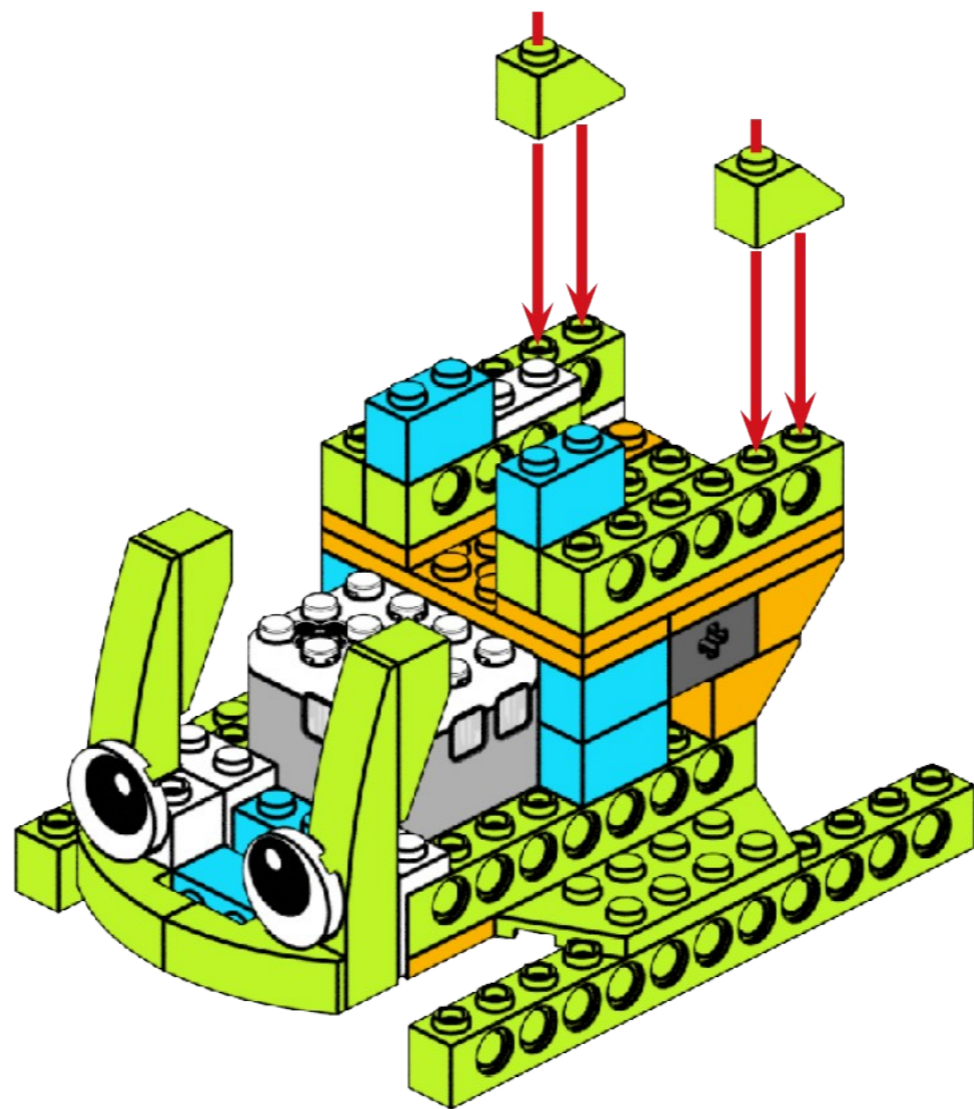

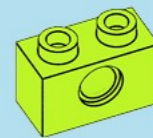
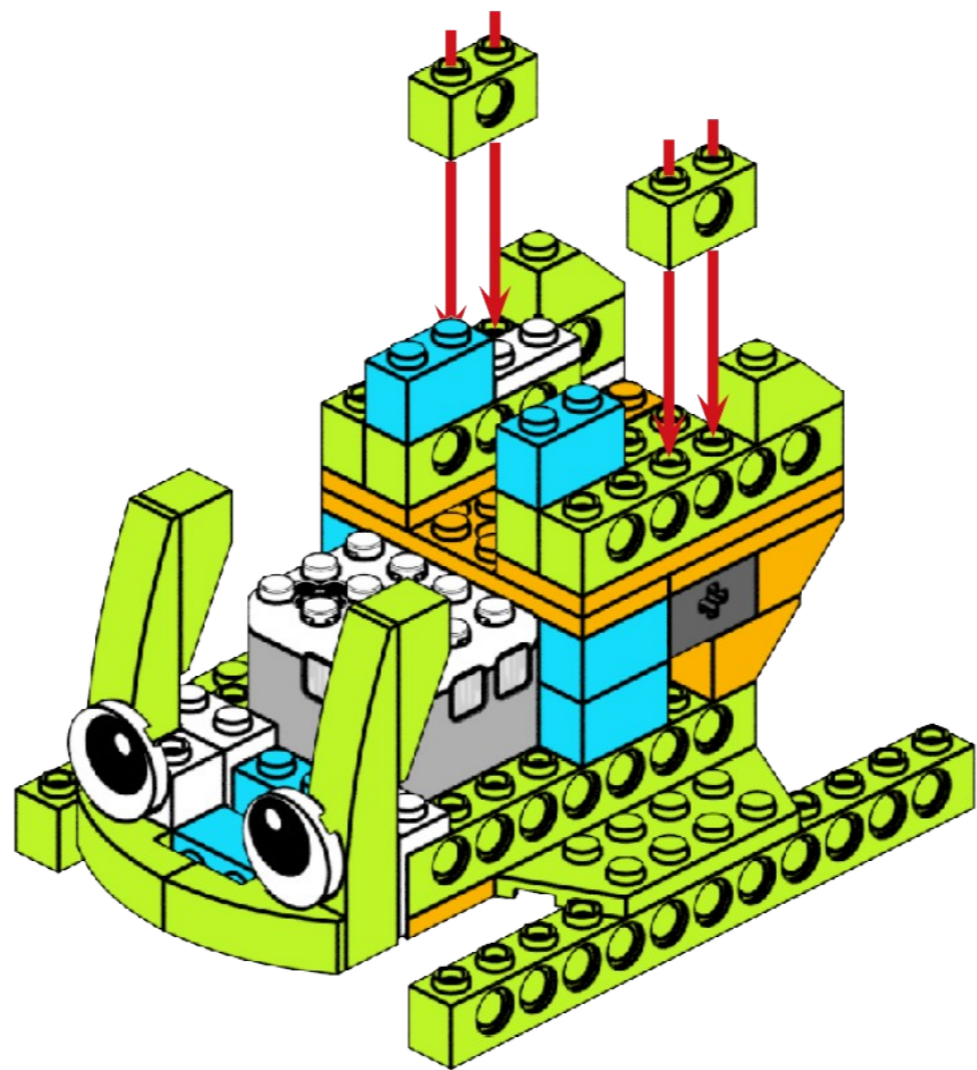

x2

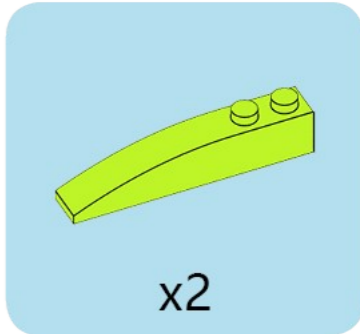
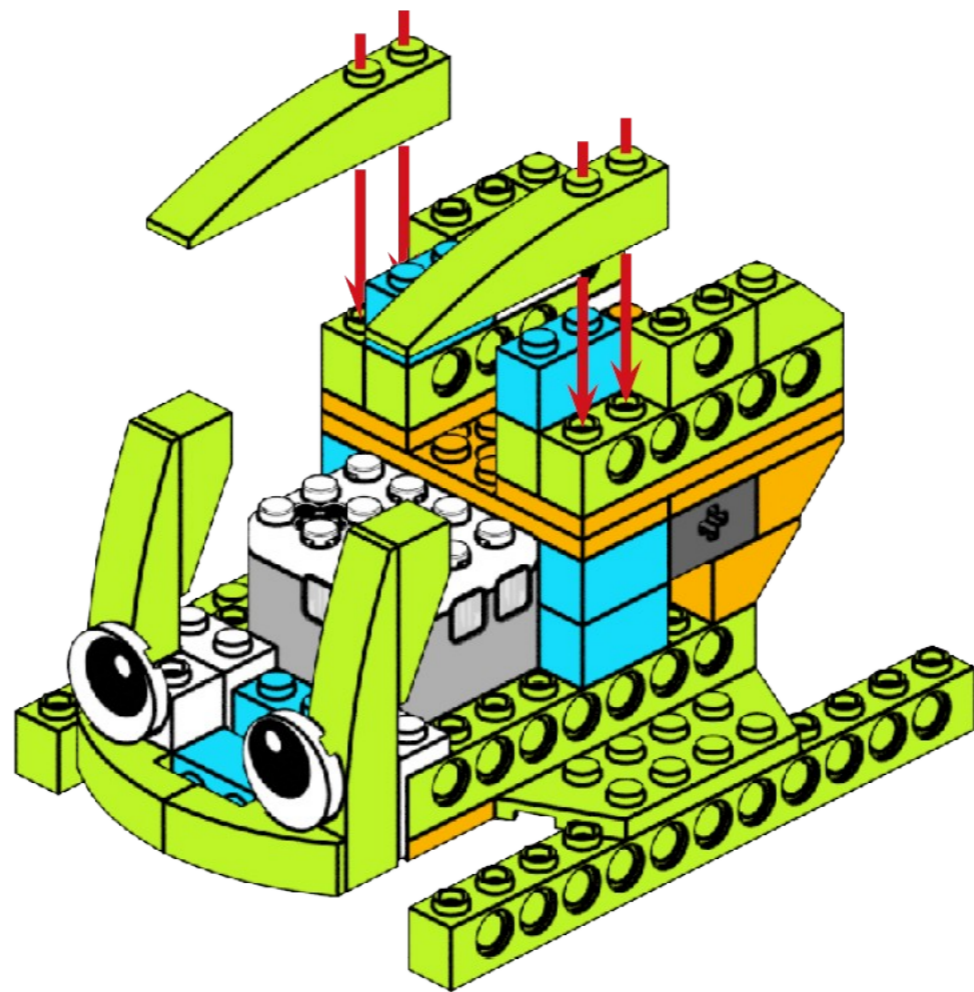

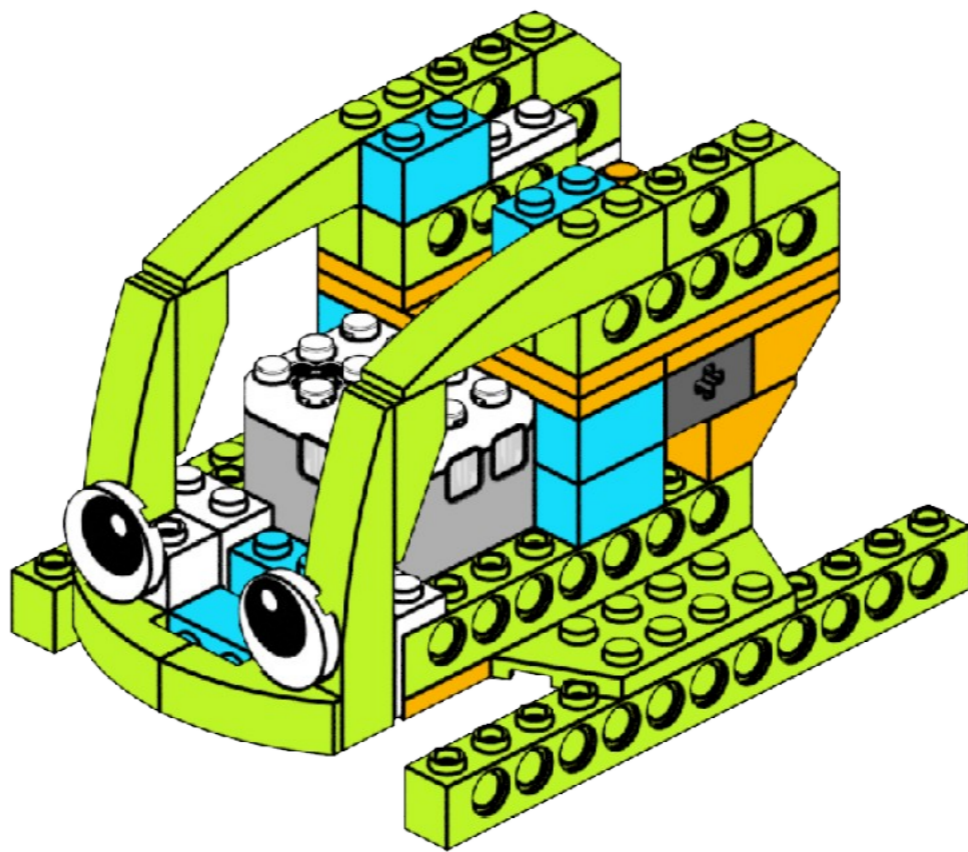



x1

7

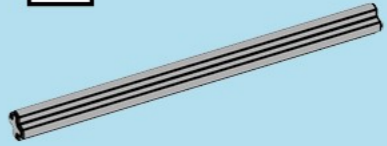

x1

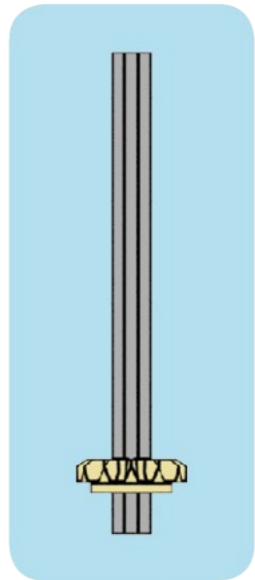

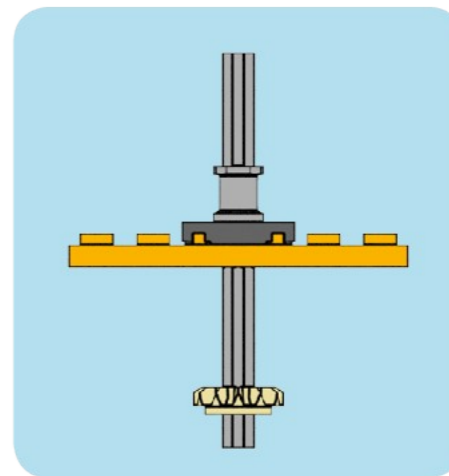
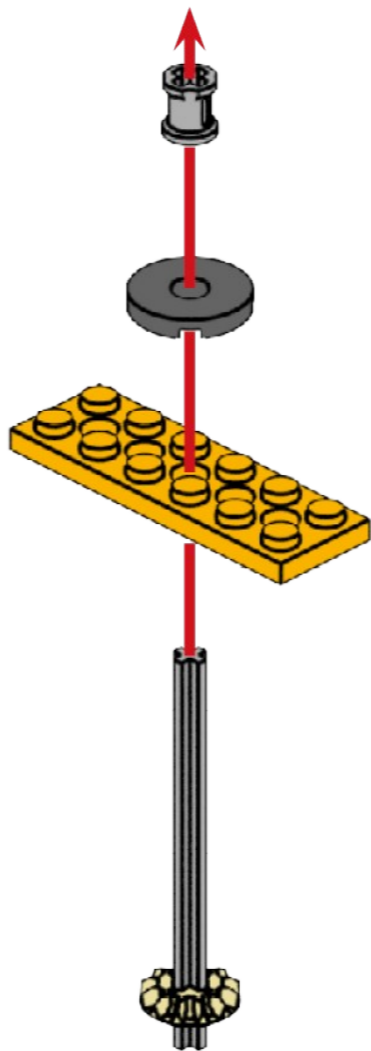

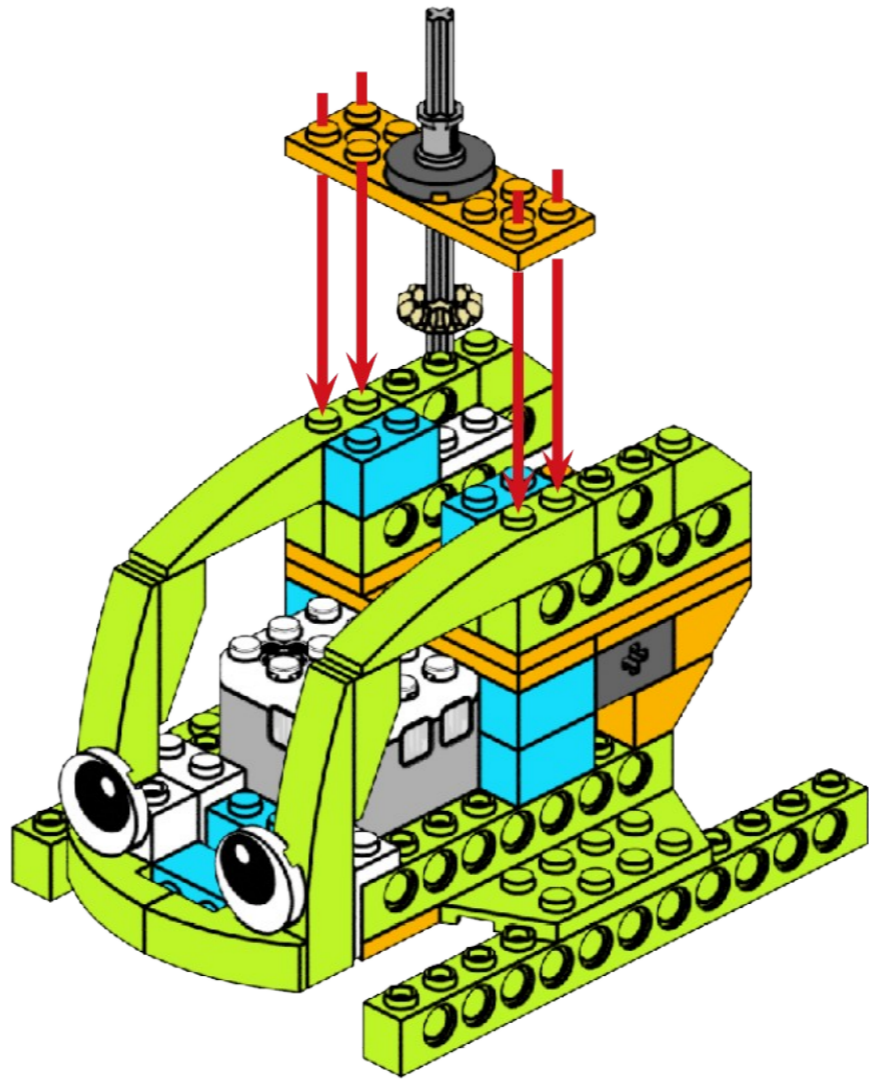

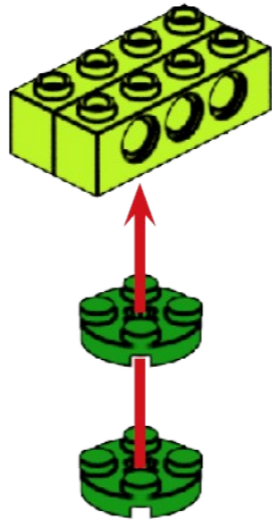
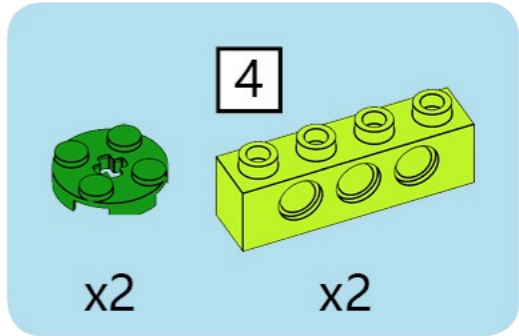

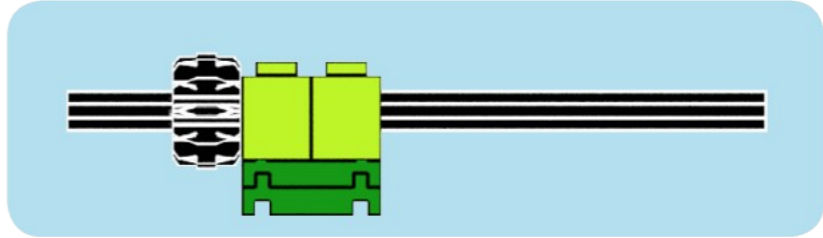
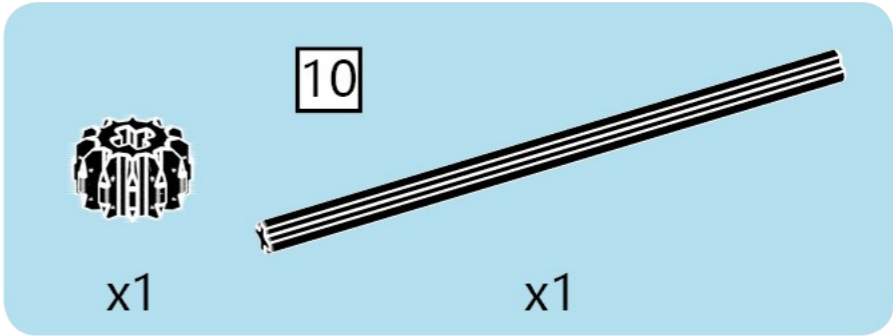
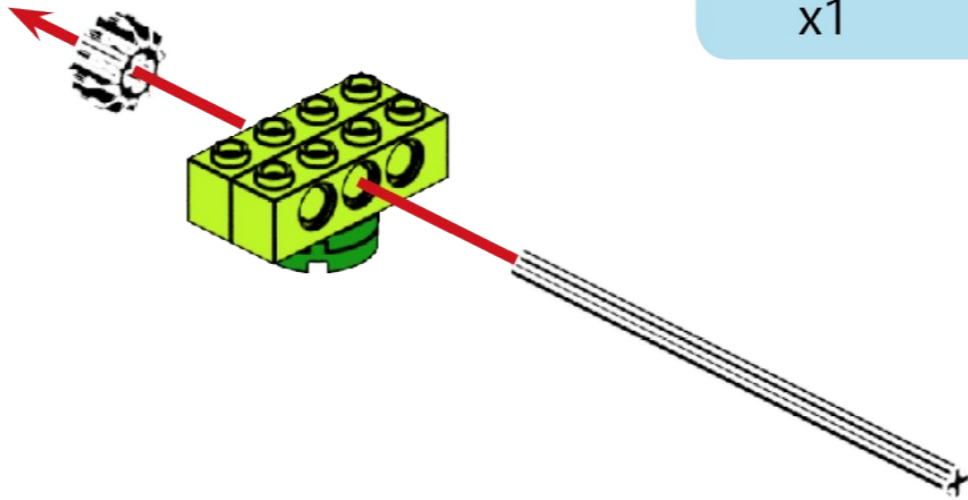

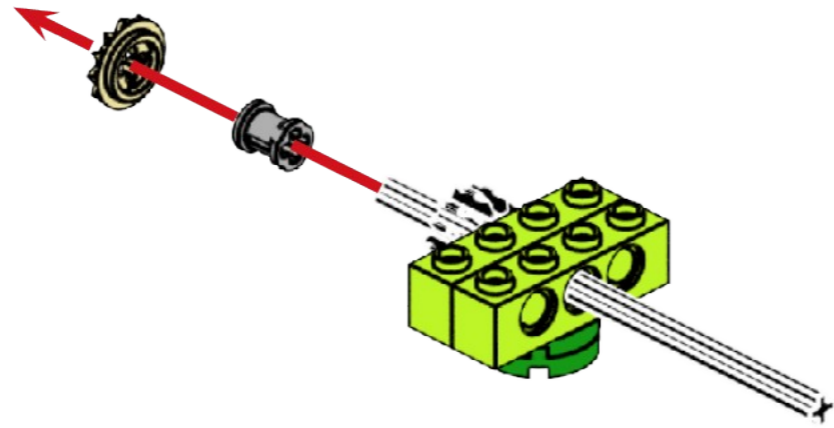

x1

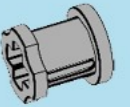

x1

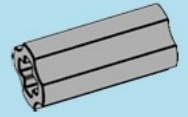
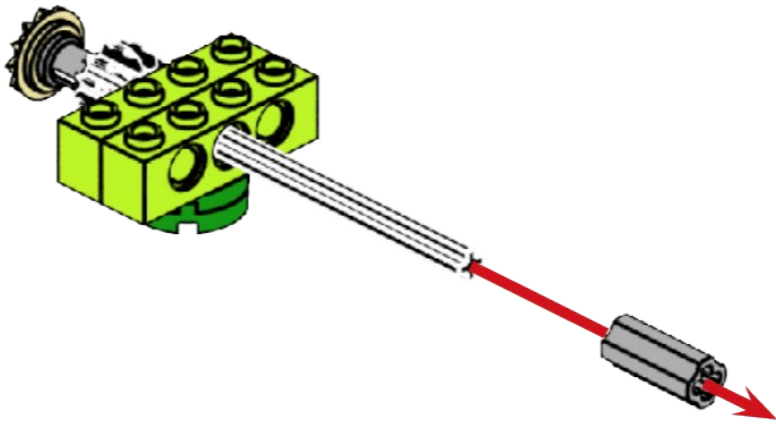

x1



8



x1

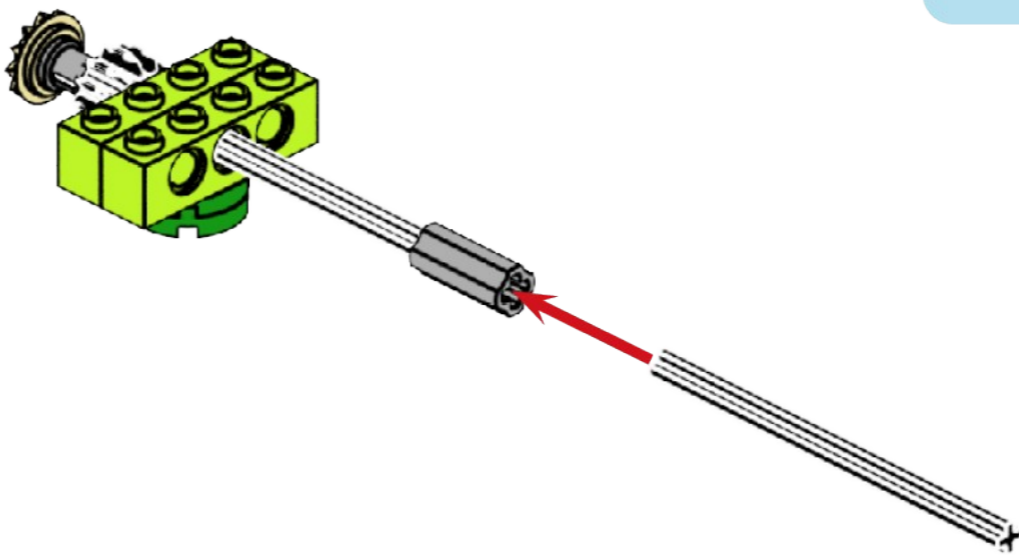

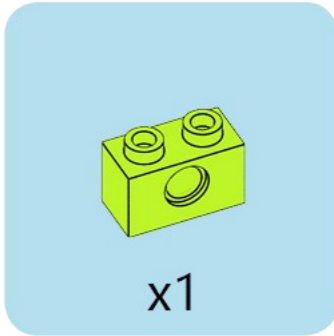
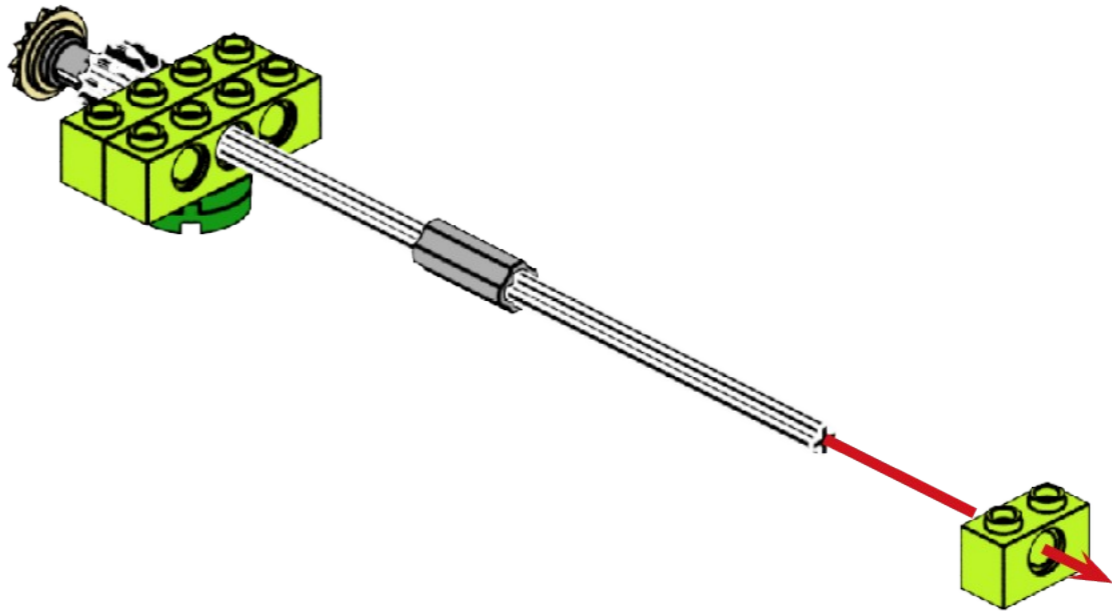

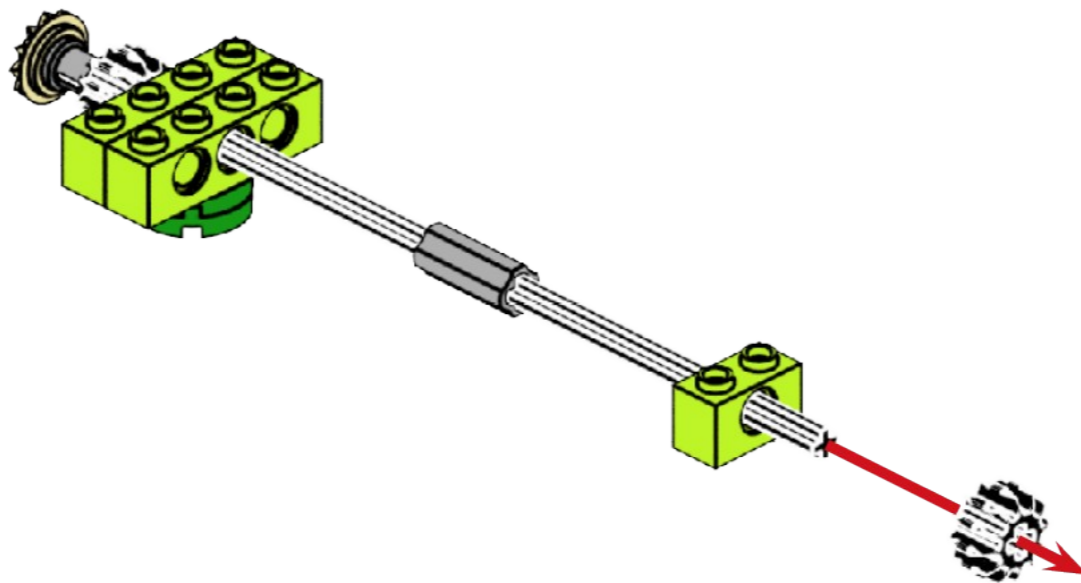

x1

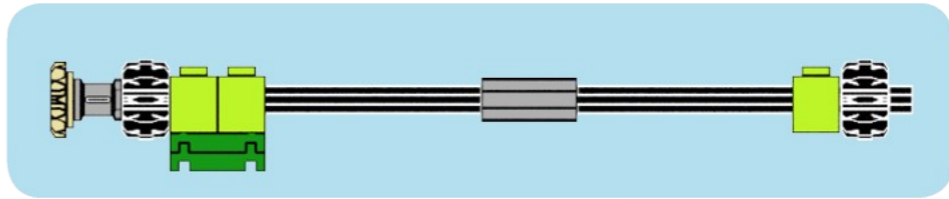

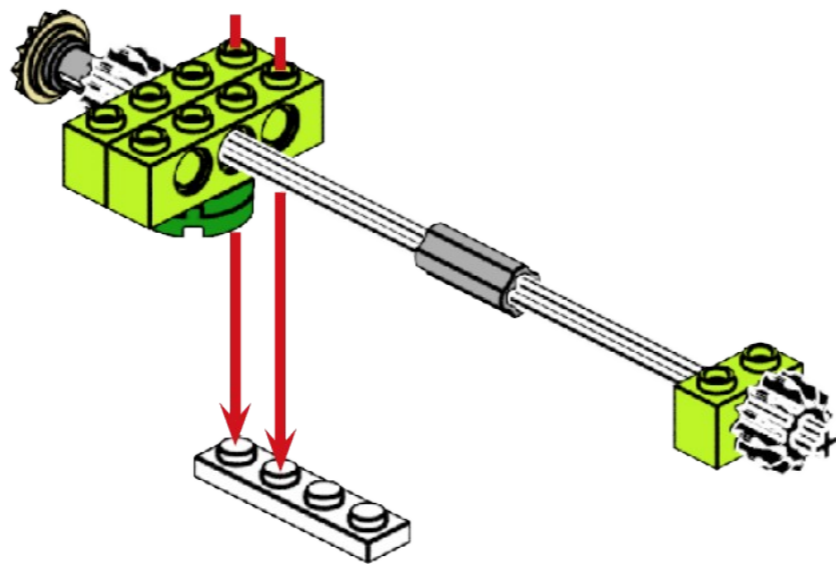
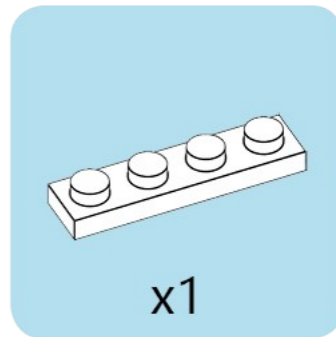



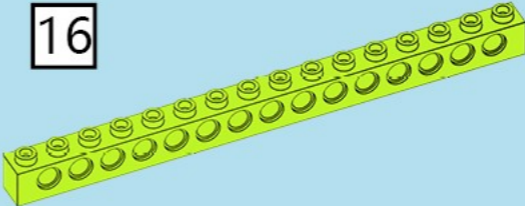

16



x1



x1



x1

3

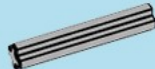

x1

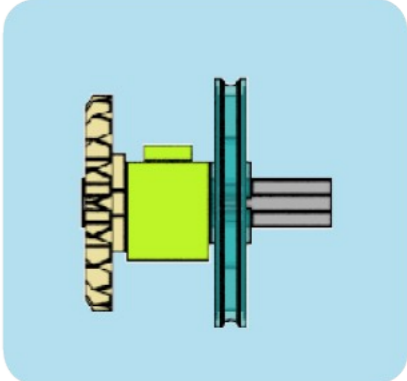
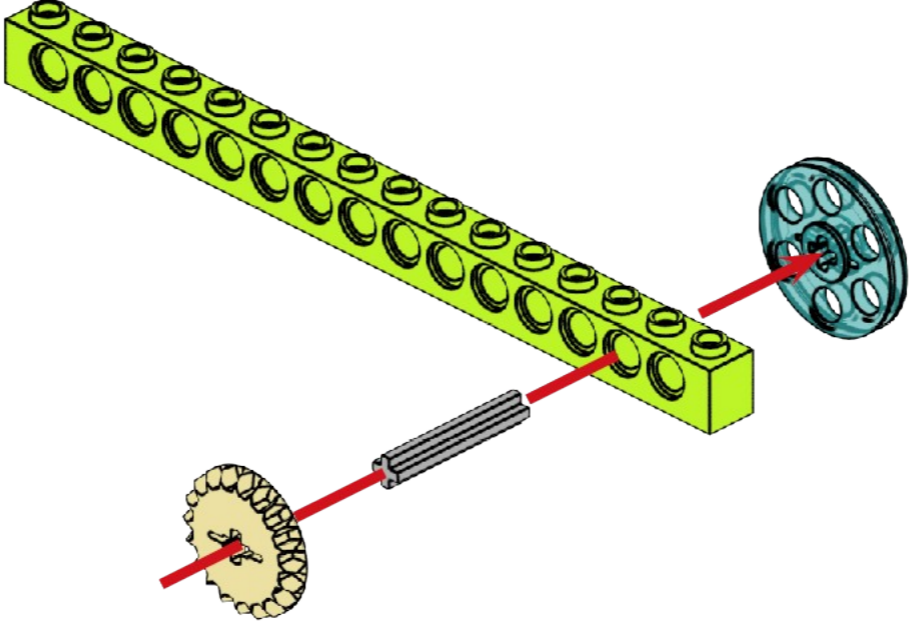

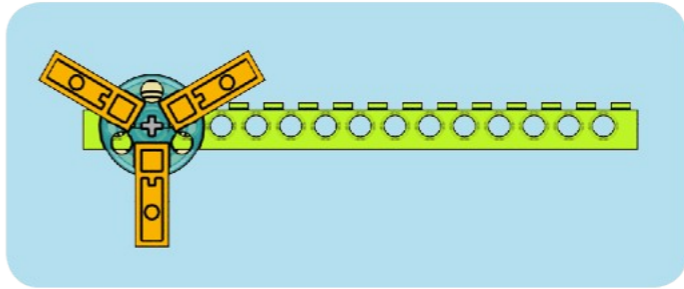
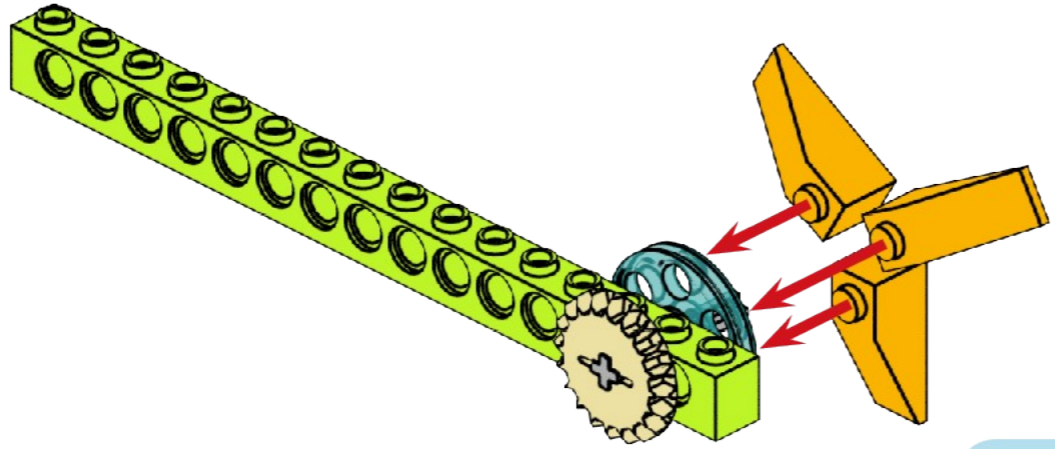
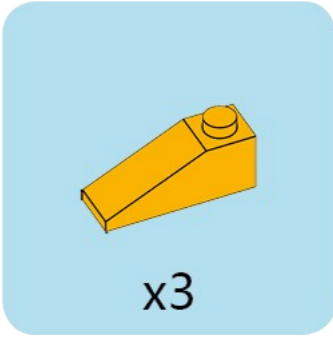

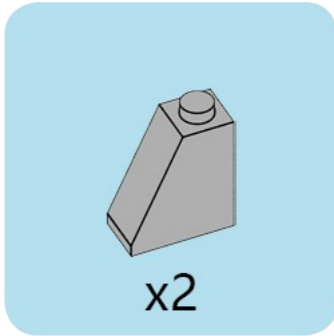
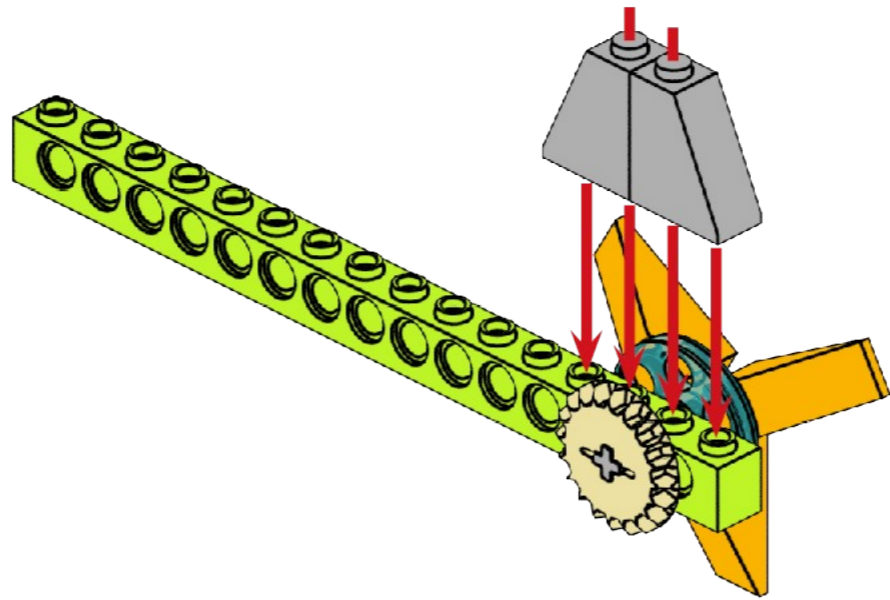

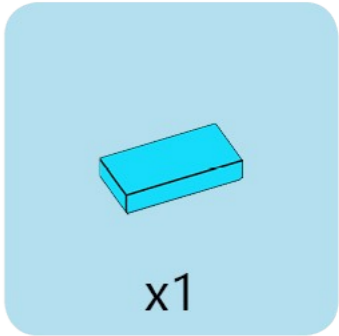
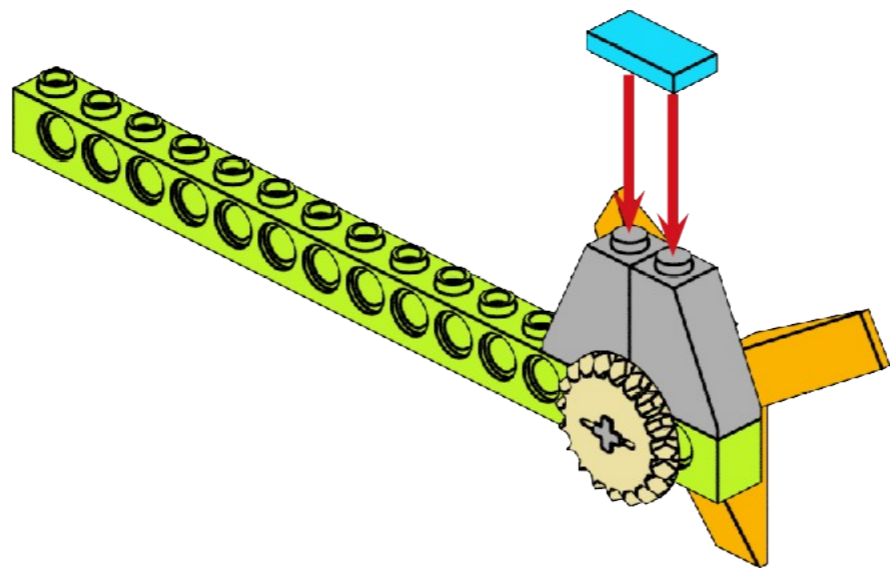

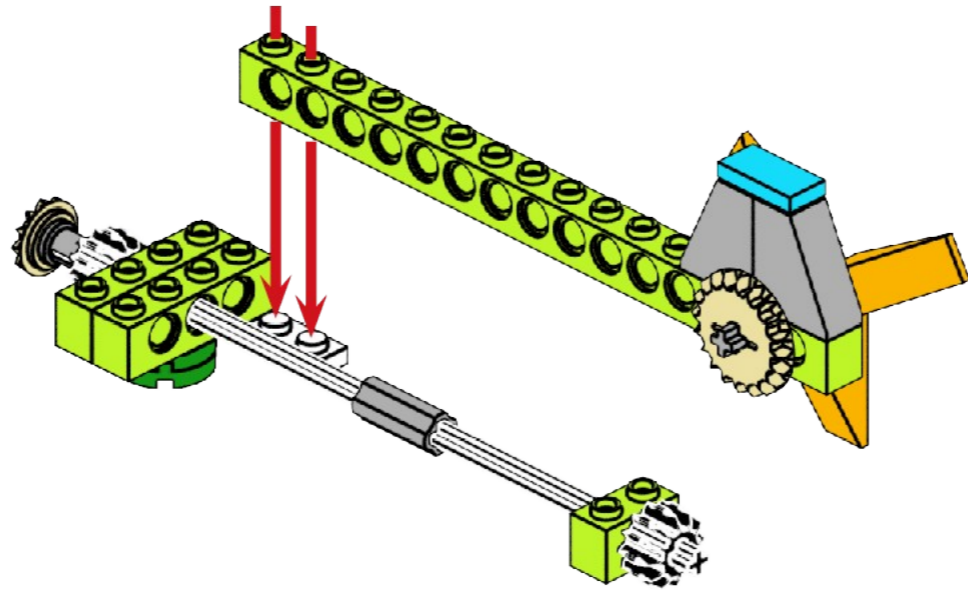

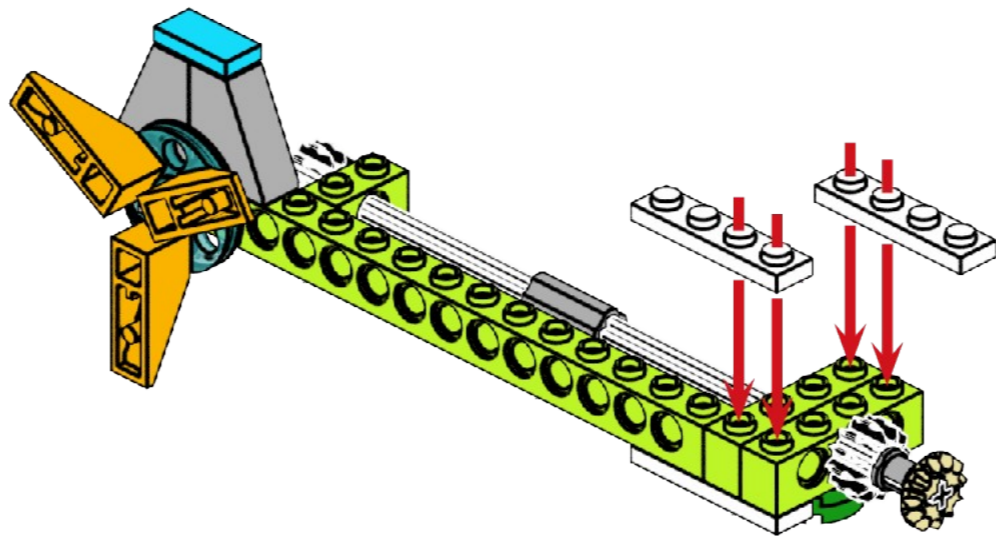
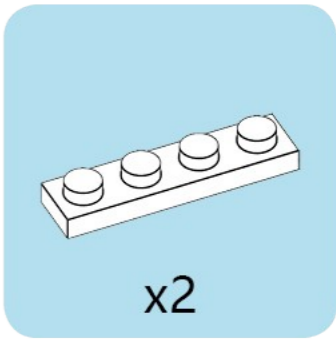

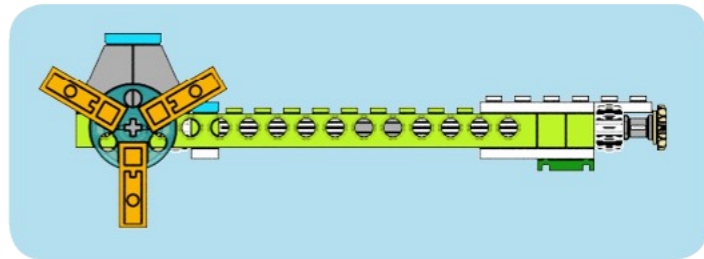
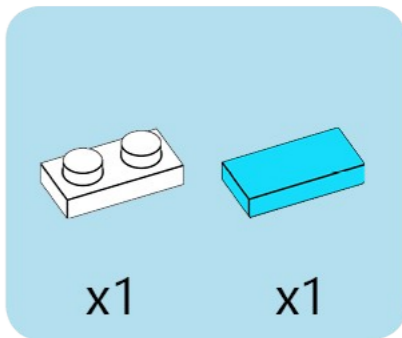
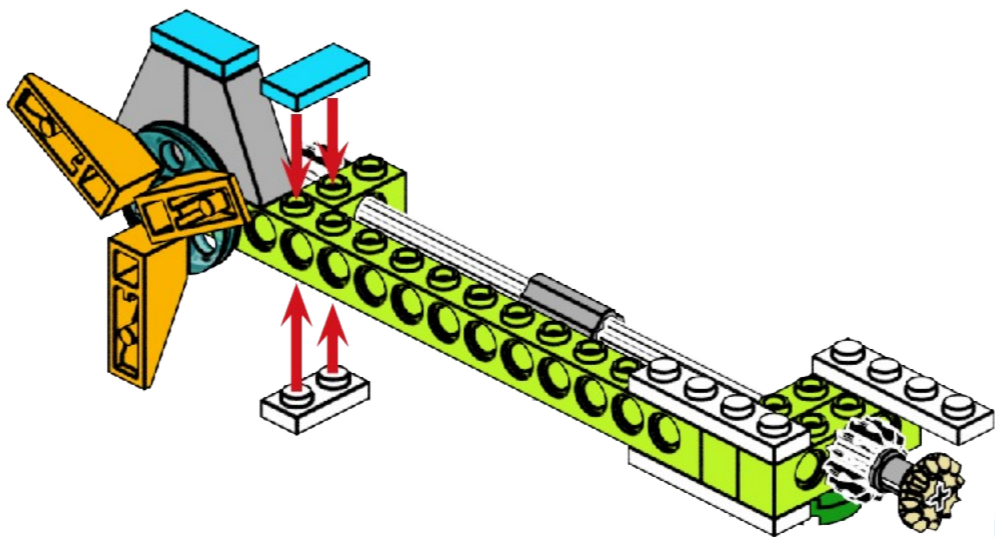

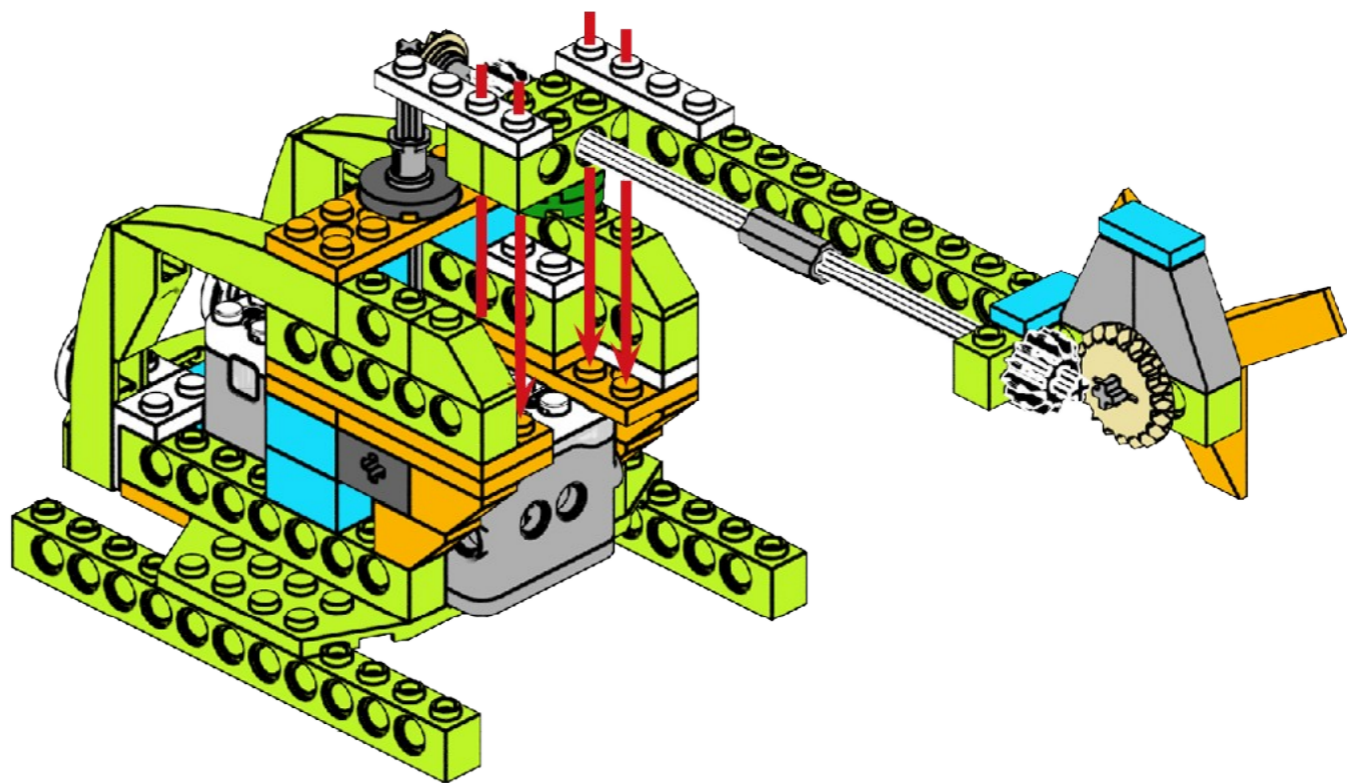

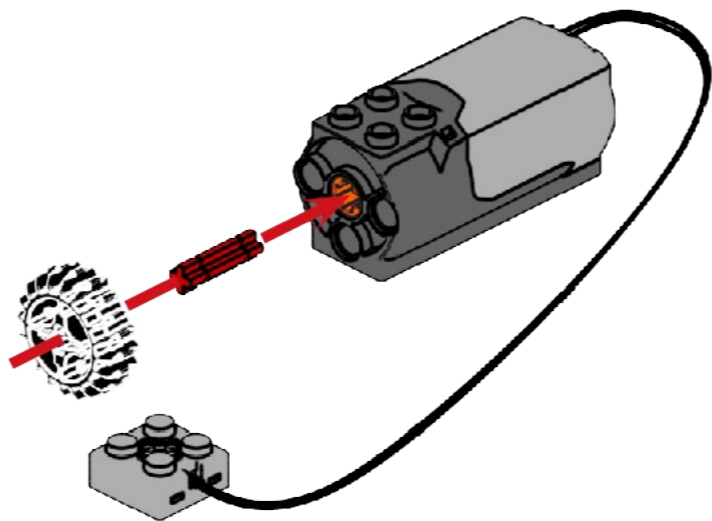
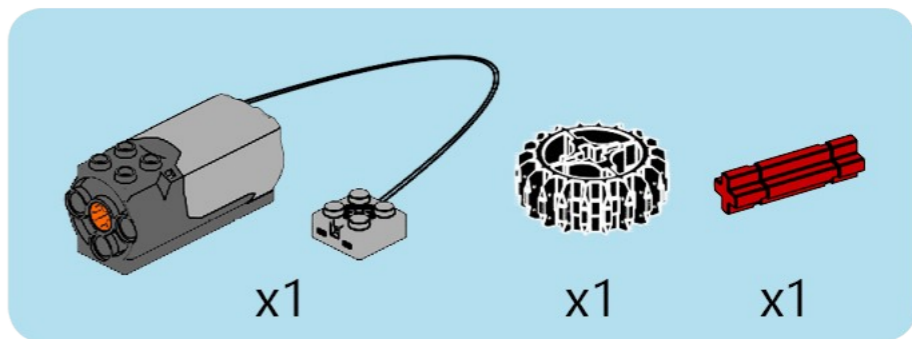

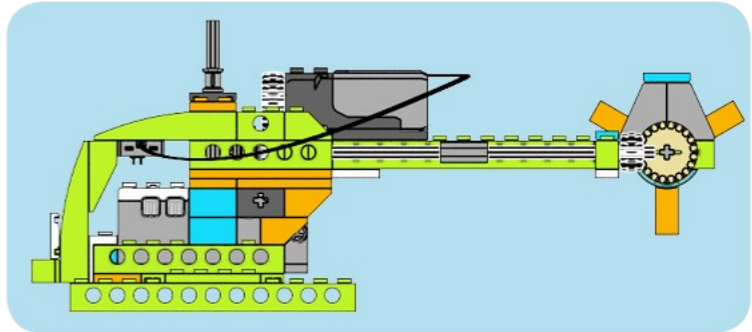
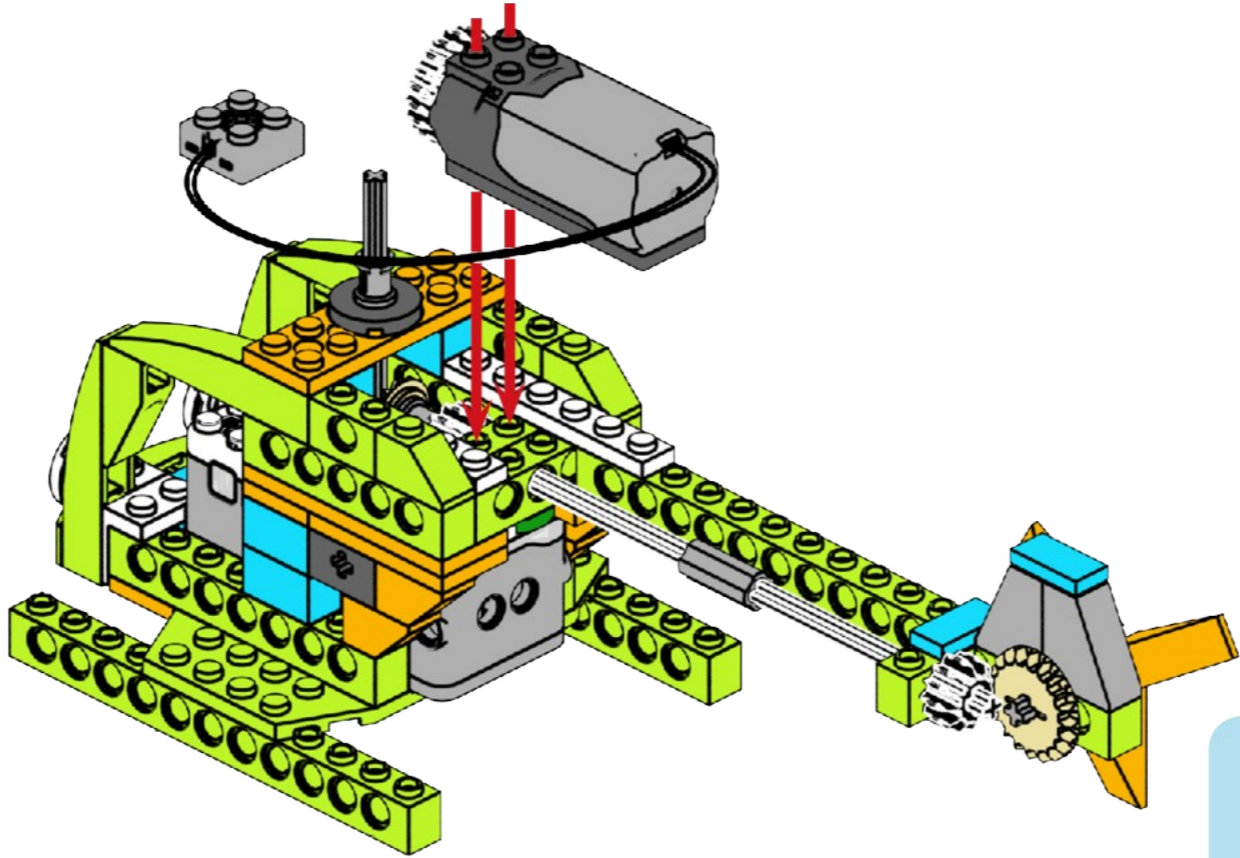

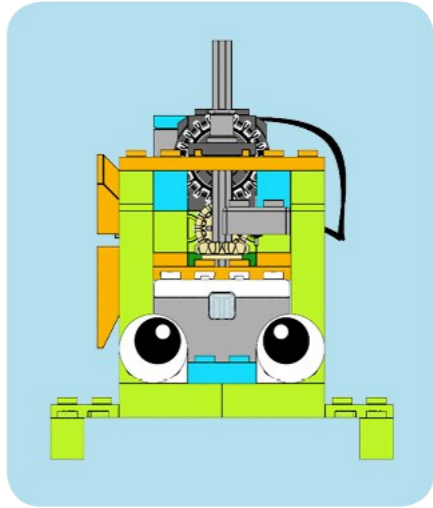
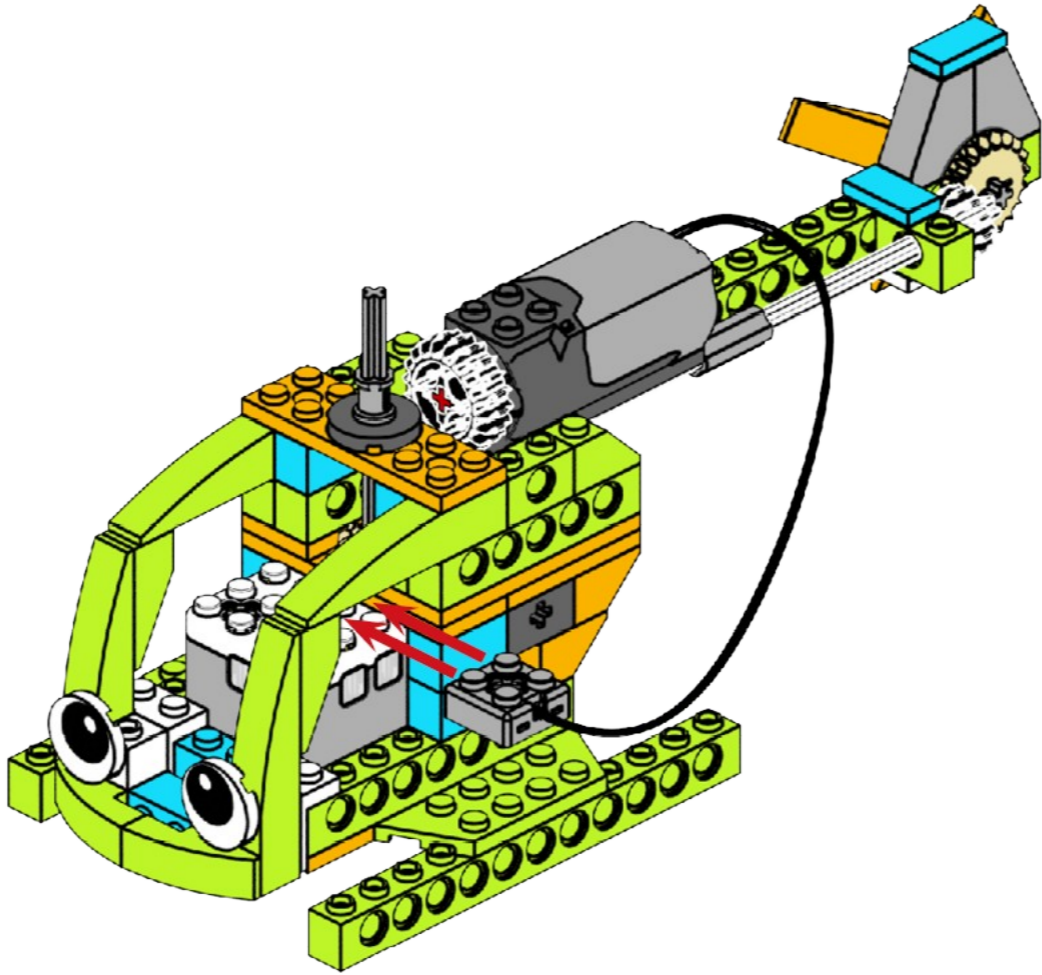

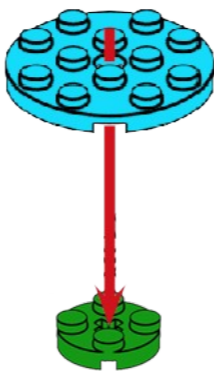

x1



x1

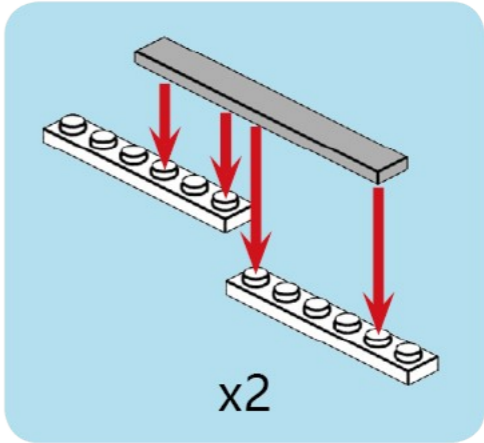
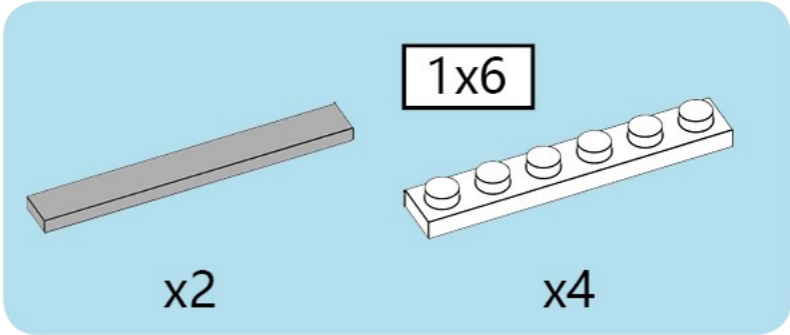
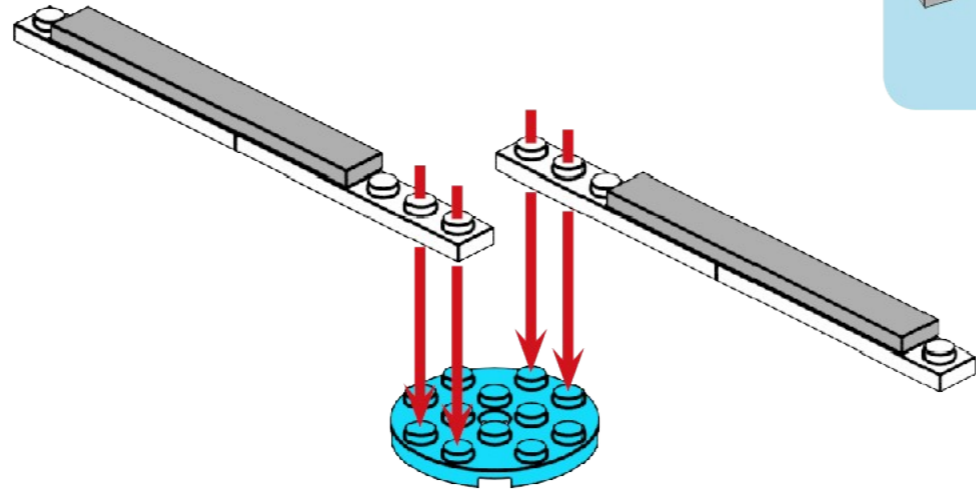

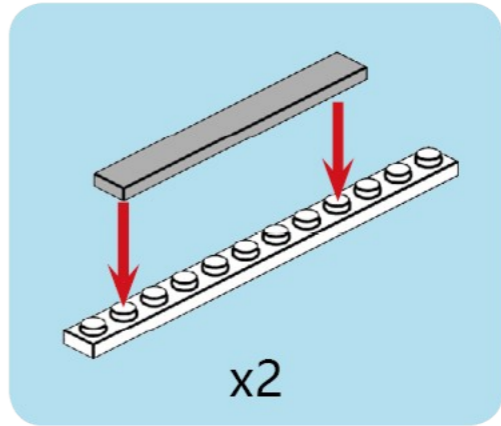
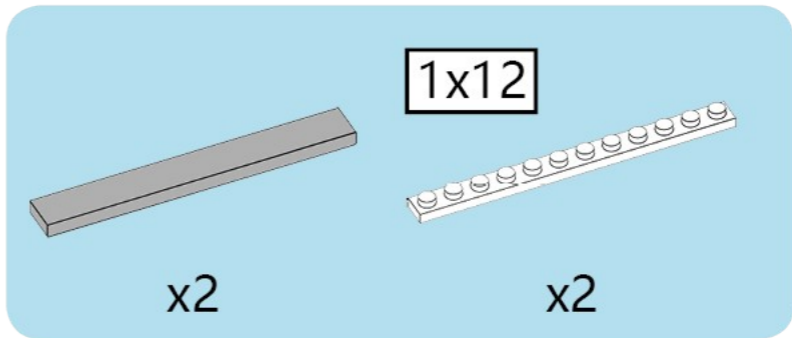
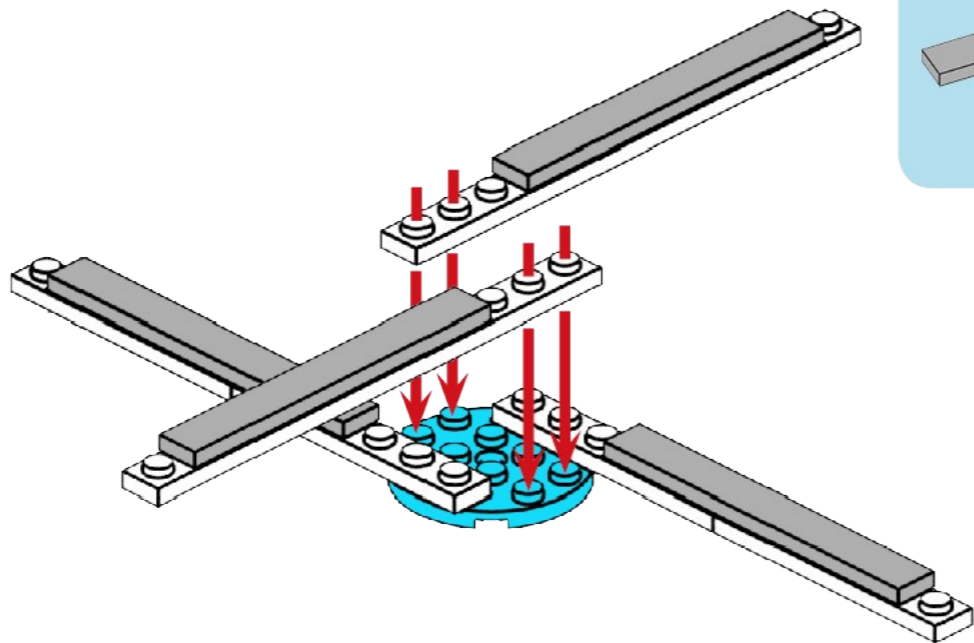

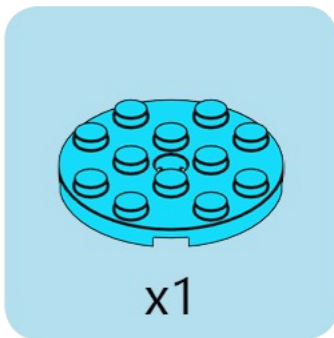
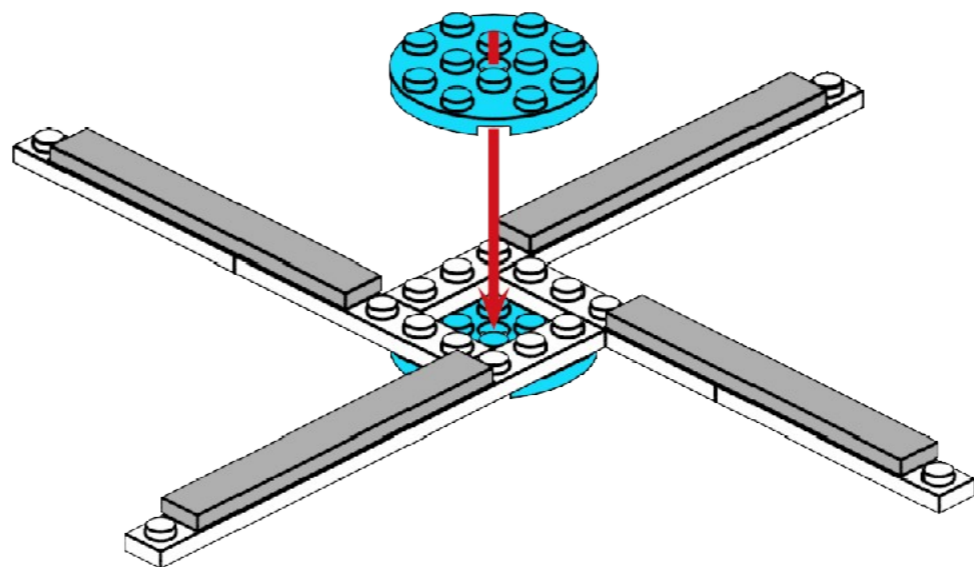

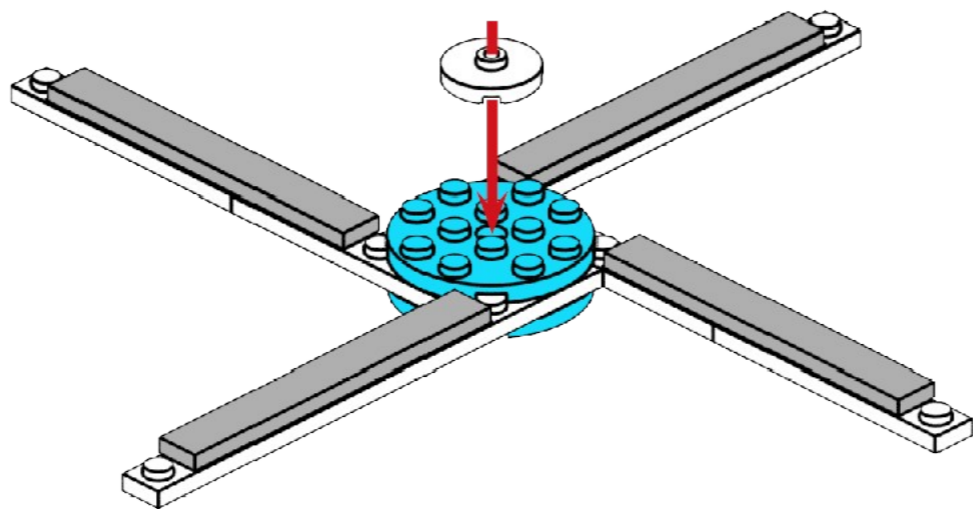
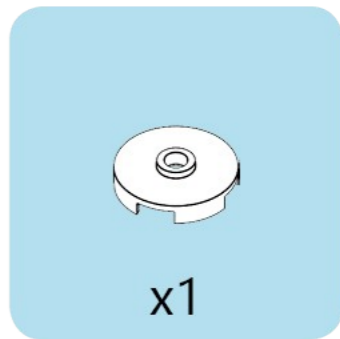

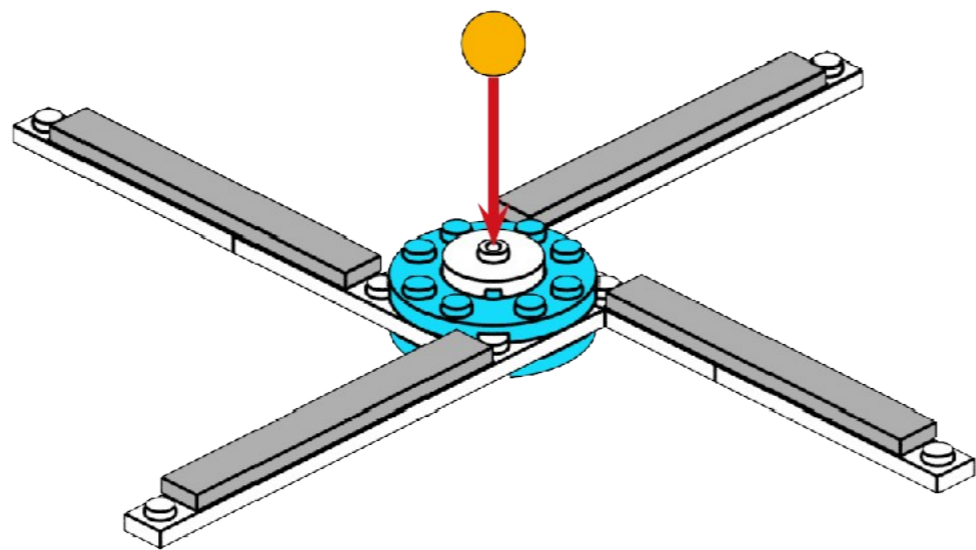
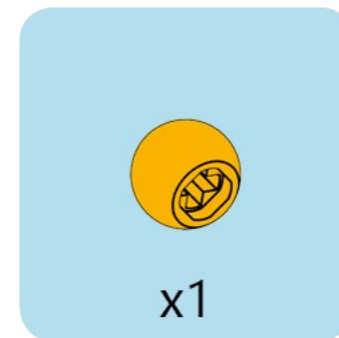

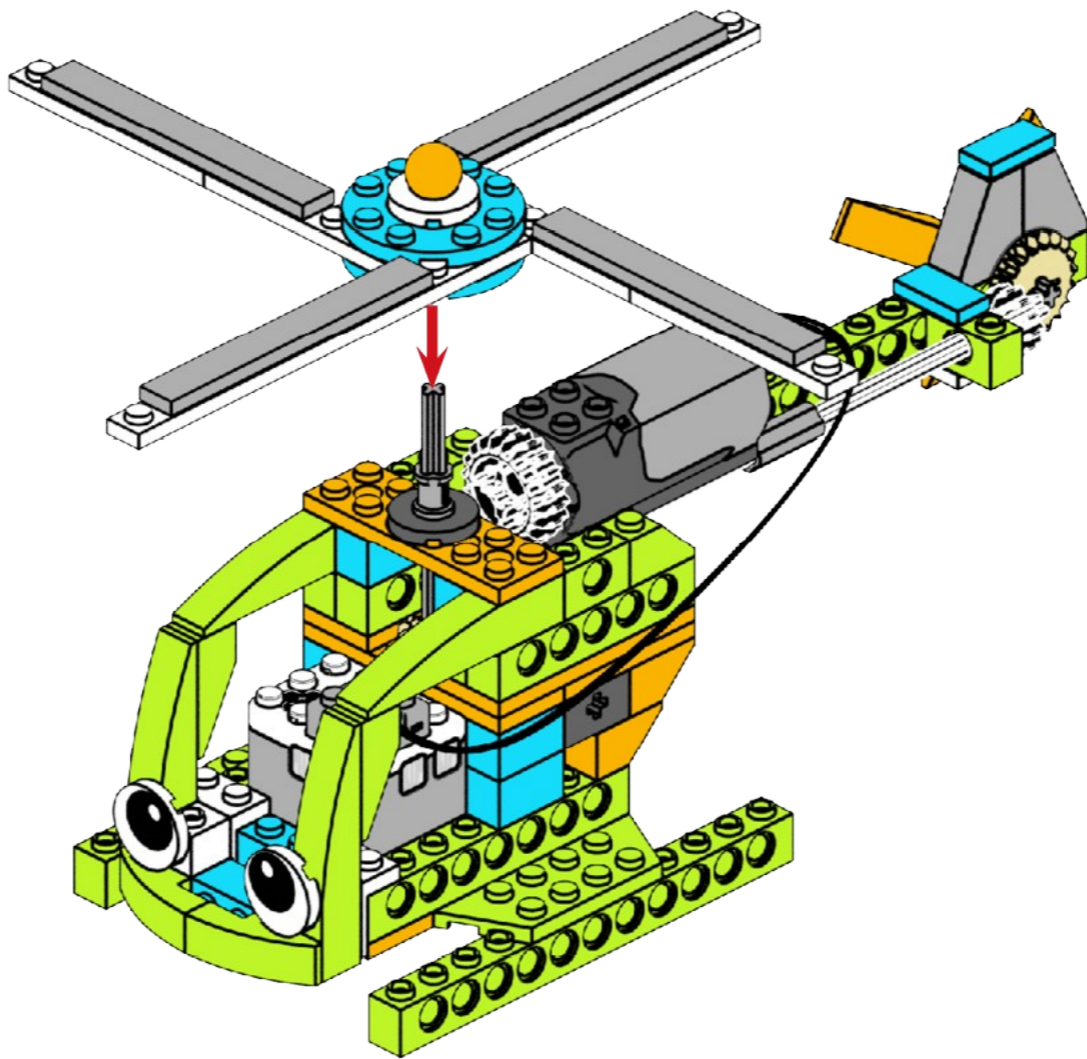

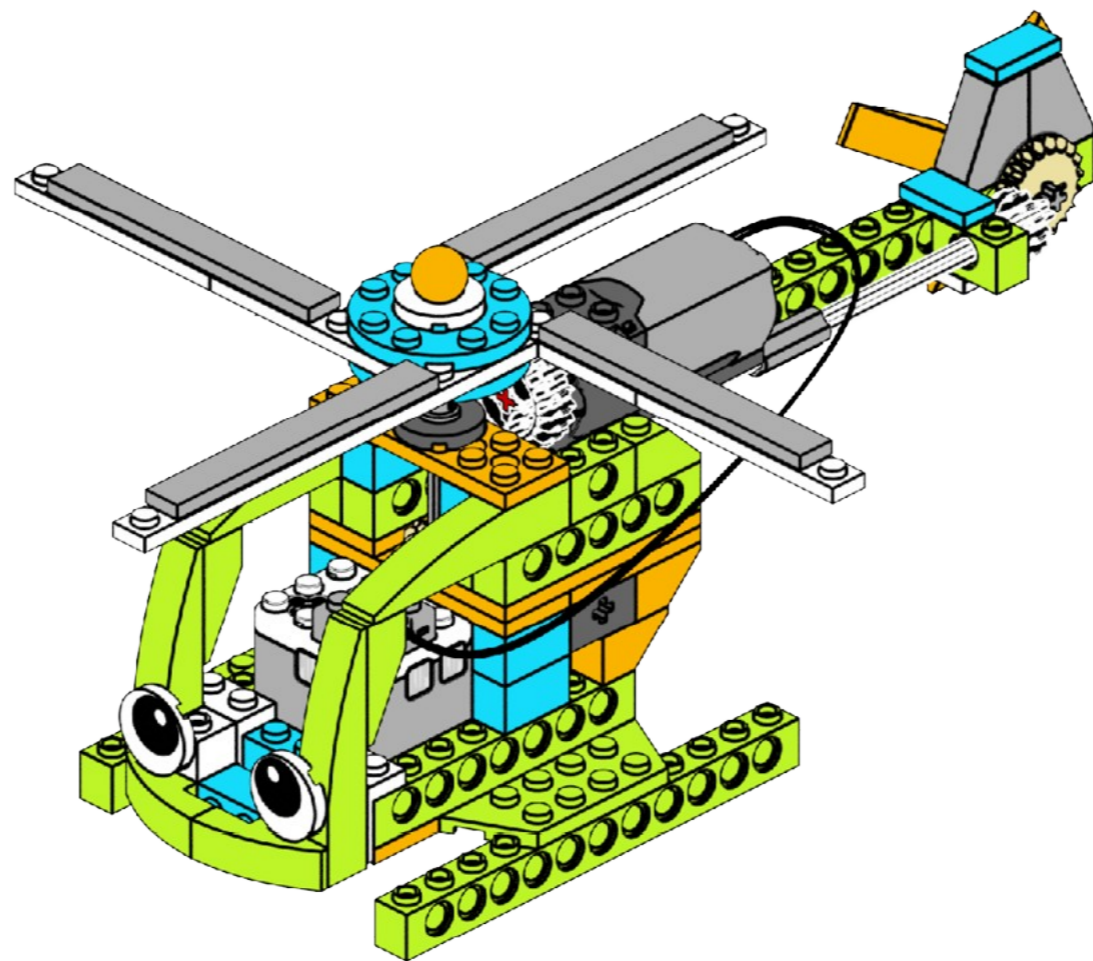

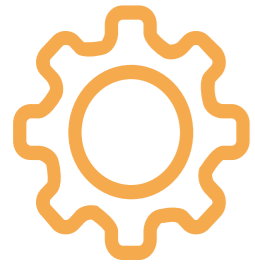

Review

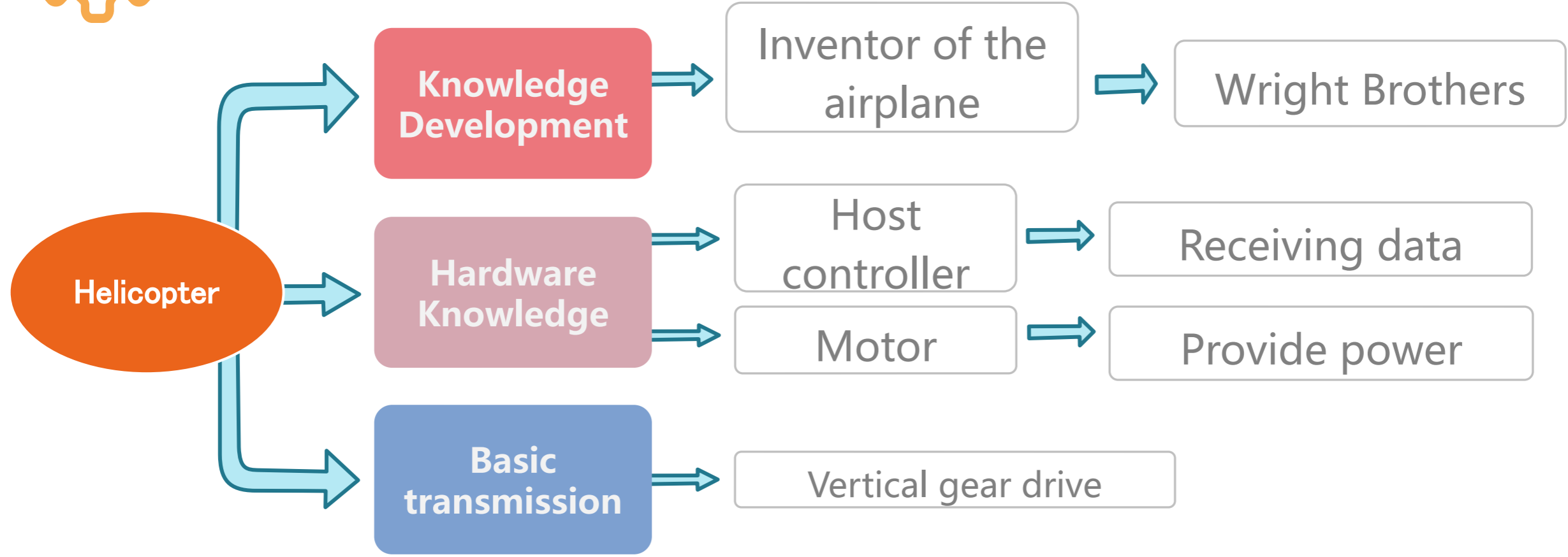

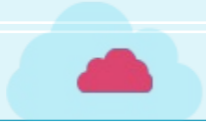

Talk





THANKS

