

Please use your own kit.

Do not put any parts in your mouth.

Please clean up after use.

Please raise your hand if you have any questions.



INTRODUCTION





Scenarios

Kids, do you know about tug-of-war? Tug-of-war is a sport where two teams each hold one end of a rope and compete to pull the rope in their direction. It is a traditional Chinese sport. The goal is for the teams to pull the red marker in the middle of the rope to their side.



Dear kids:
How can we make the robot play tug-of-war?
How can we improve the performance of the tug-of-war robot?

Let's have a "tug-of-war competition" and kick off our exploration journey together!

Tug-of-War Competition

AI Courses





Scenarios

Question :

Dear kids, Do you know

How to achieve robot tug-of-war?

How to improve the performance of tug-of-war robots?

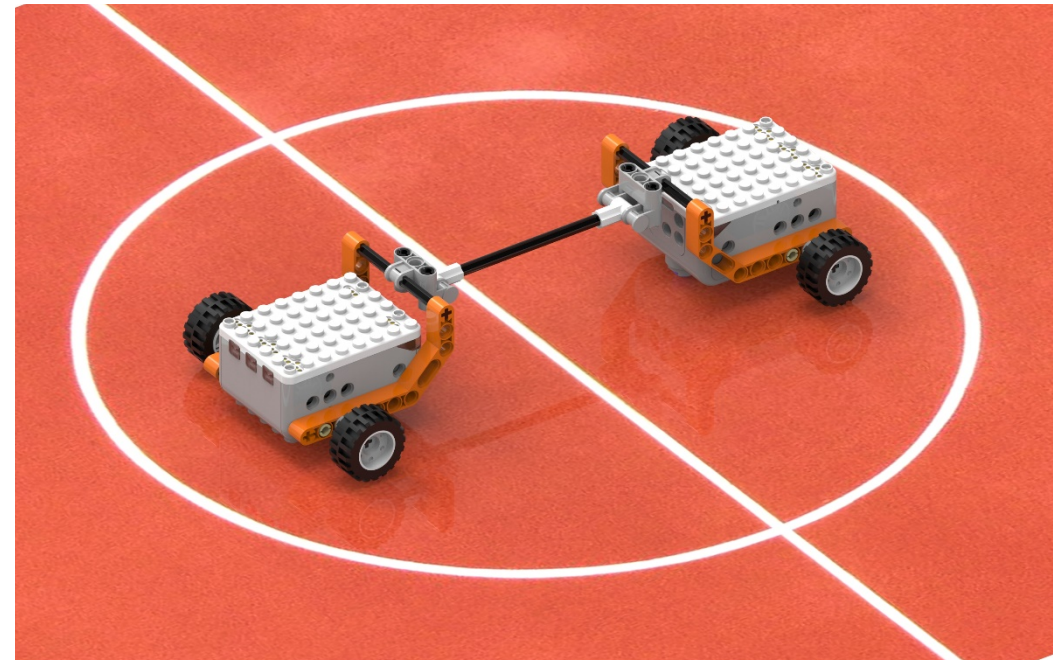



Scenarios

Today, you are all little engineers. Let's build the Superbot tug-of-war together!

Link device

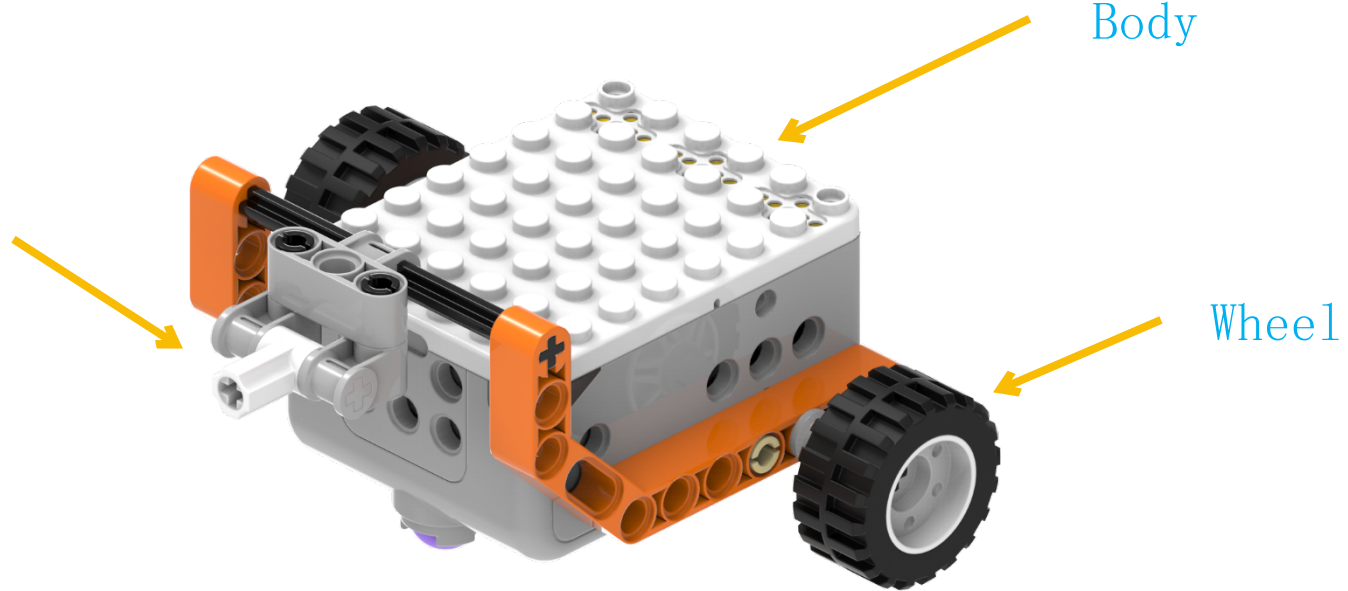

ASSEMBLY





The Final Model

Assembling the body and link device

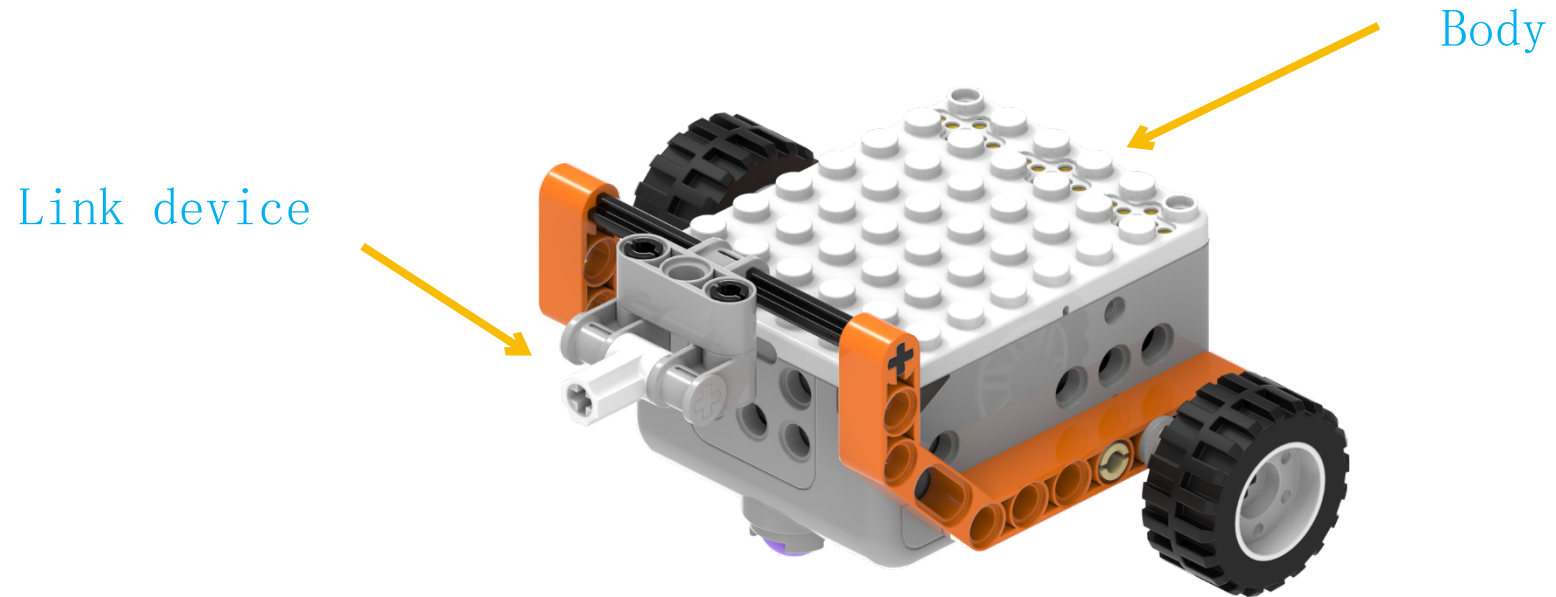



Assembly

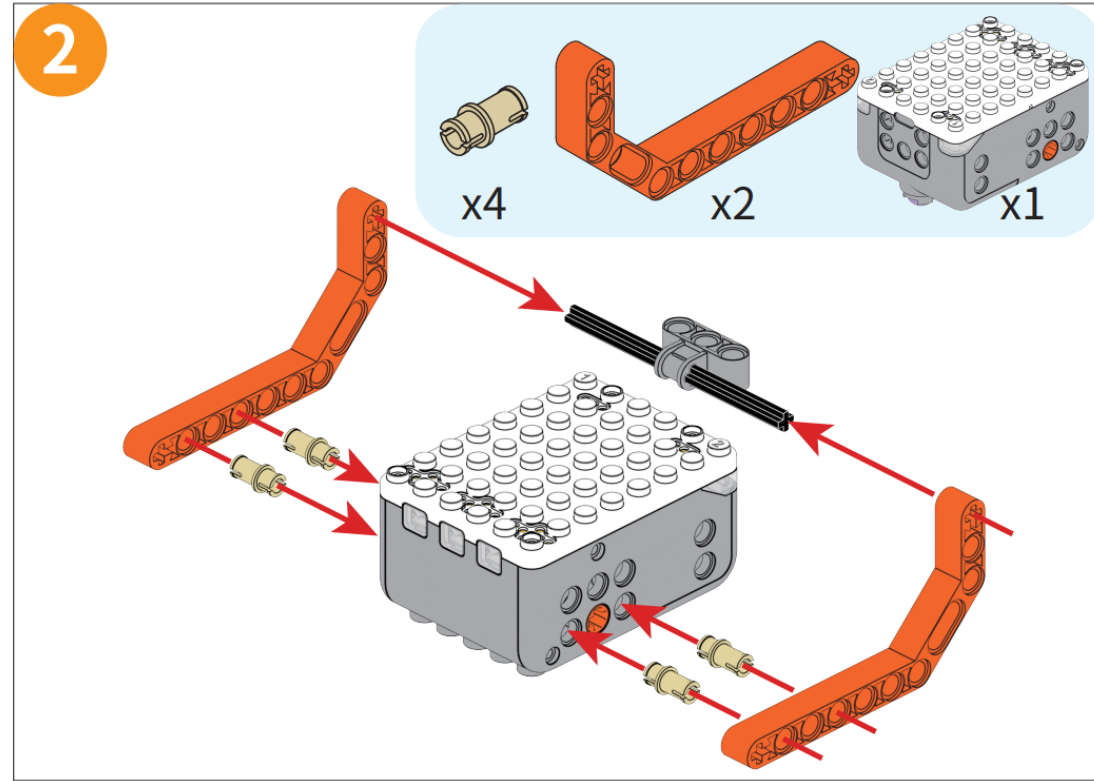
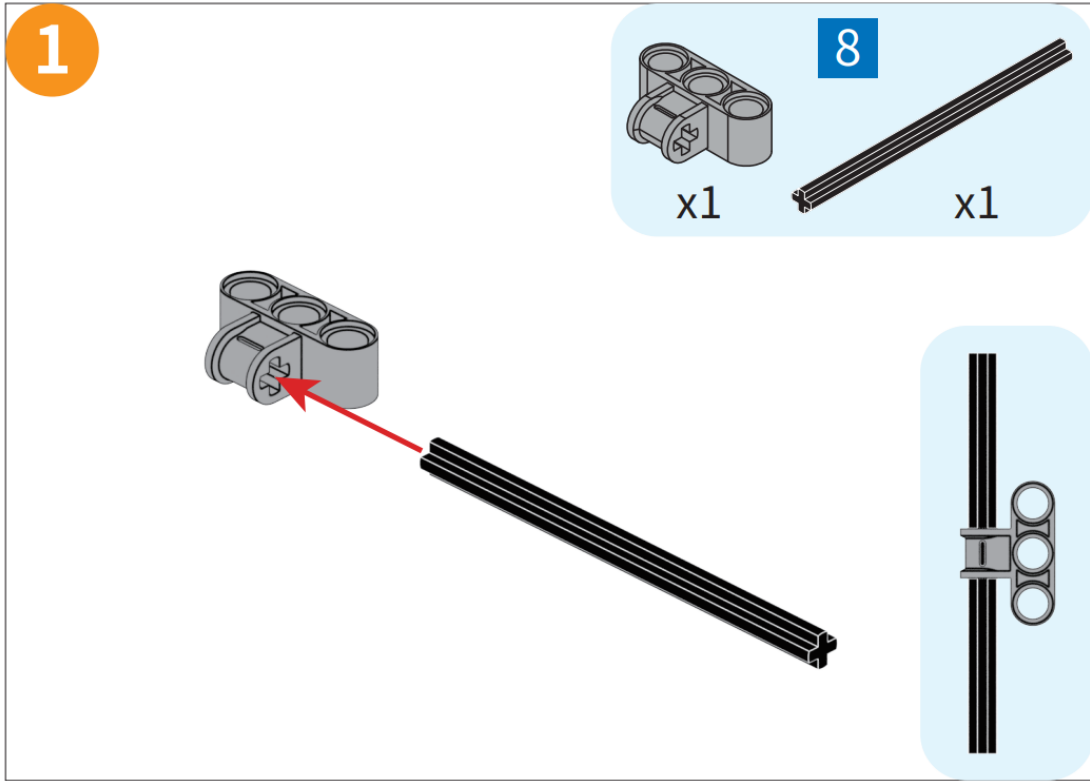



Assembly

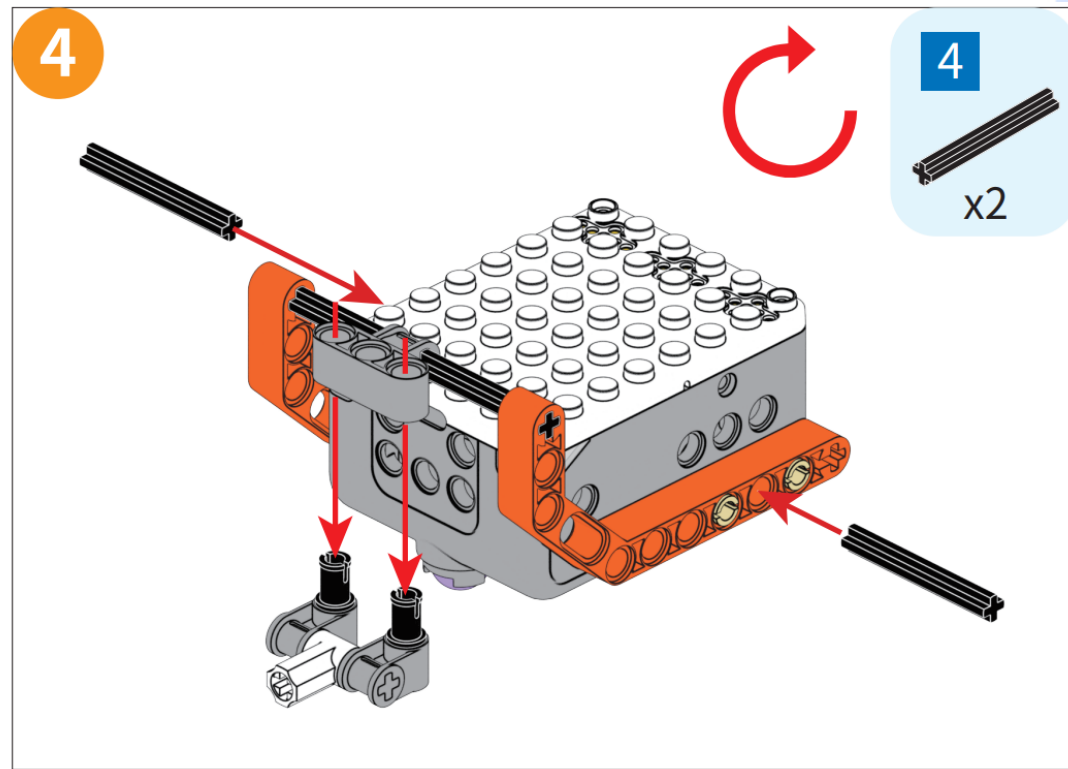
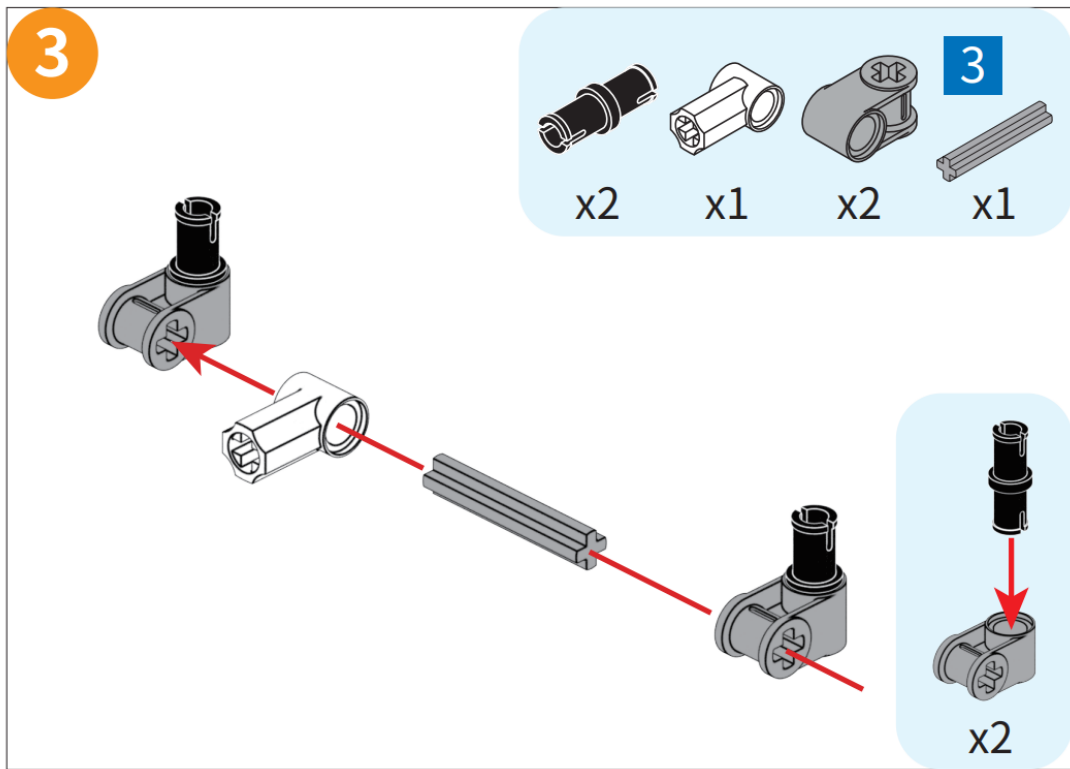



Assembly

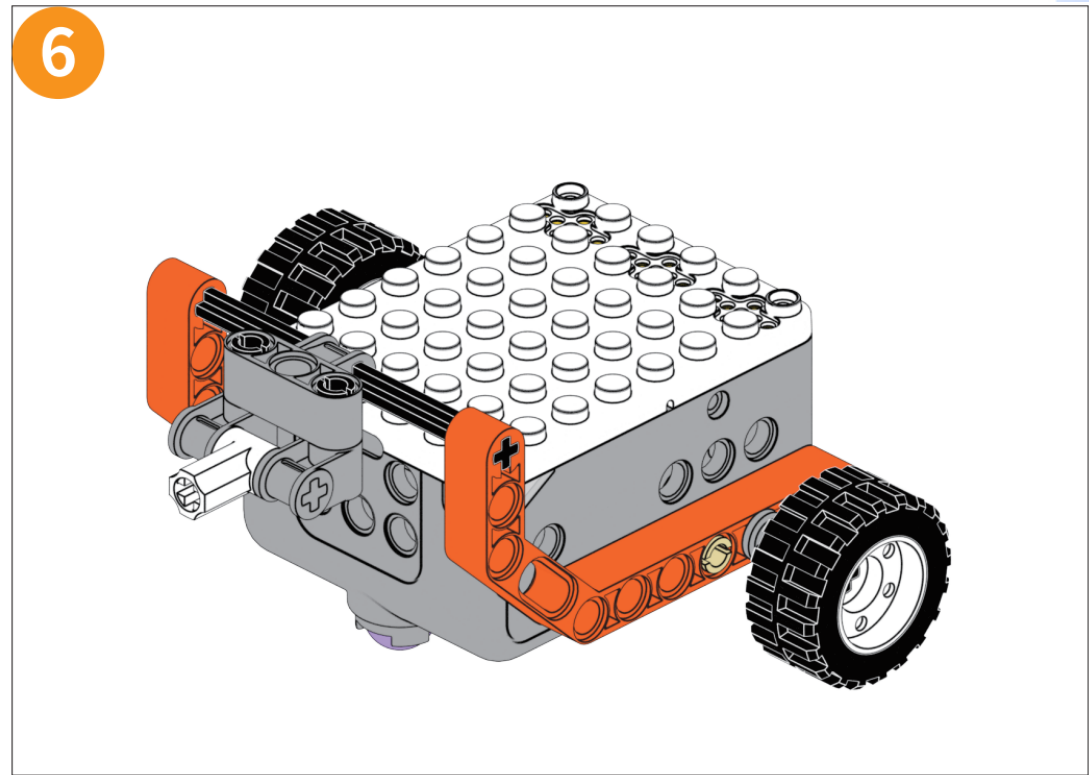
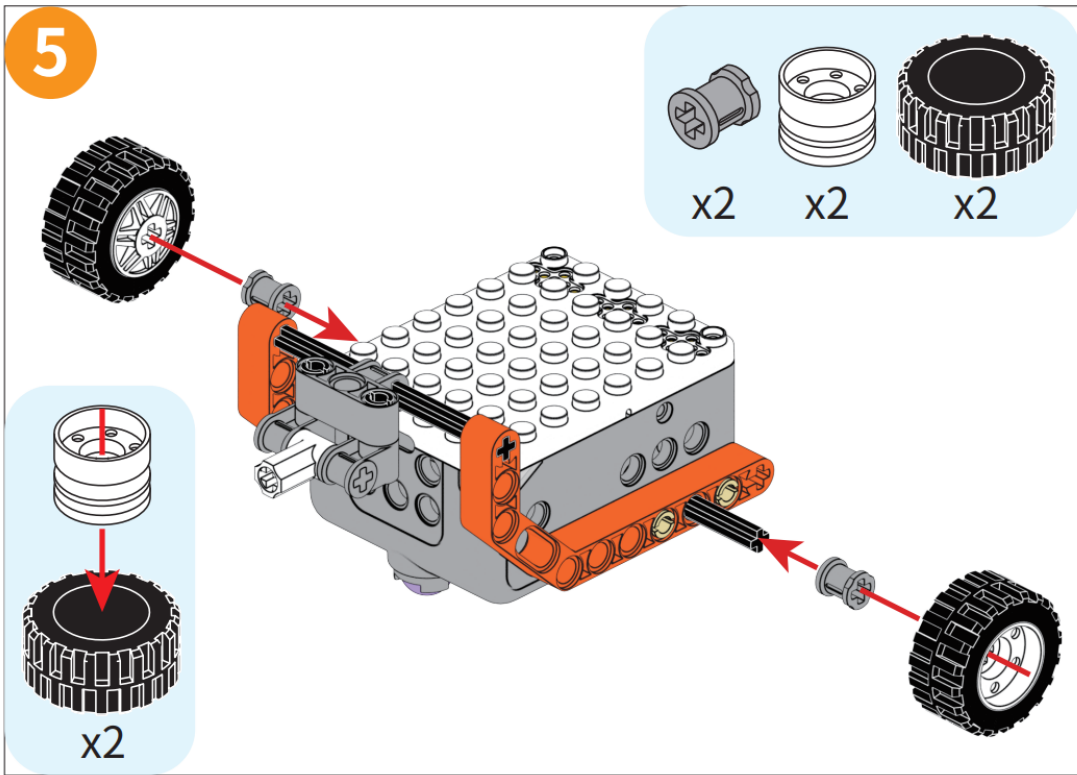

PROGRAMMING





Introductions

Module Explanation

set double built-in motors to keep running by speed at 1# (- 50)% and 2# 50 %

set double built-in motors to keep running by speed at 1# (50)% and 2# 50 %

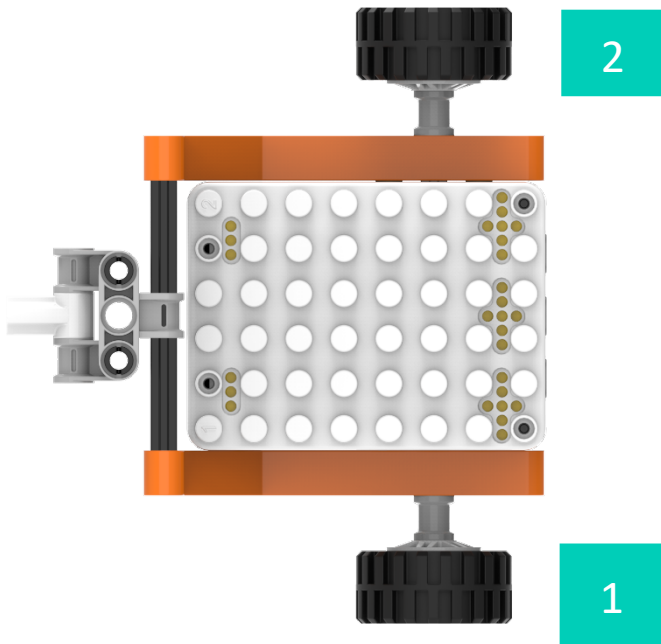

Control the two motors of the Super Robot at the same time.

set 1# built-in motor to keep running at 50 % speed on clockwise

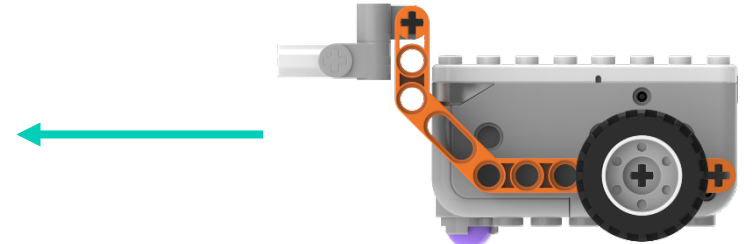

set 2# built-in motor to keep running at 50 % speed on clockwise





Introductions

Module Explanation

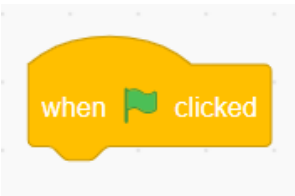

The program runs when the green flag is clicked.

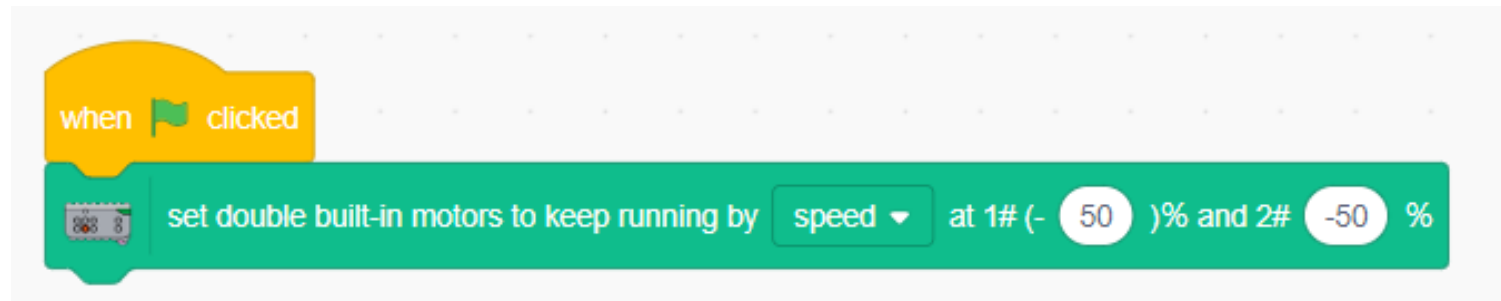
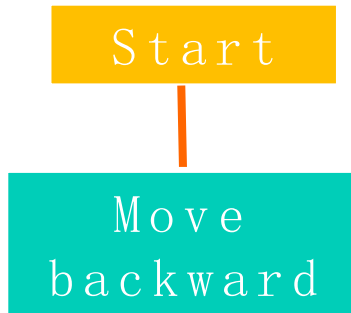



Play and Try

Let's give it a try:

Click the start button to see if the tug-of-war robot can move backward.



```
when clicked
  set double built-in motors to keep running by speed at 1# (- 50 )% and 2# -50 %
```

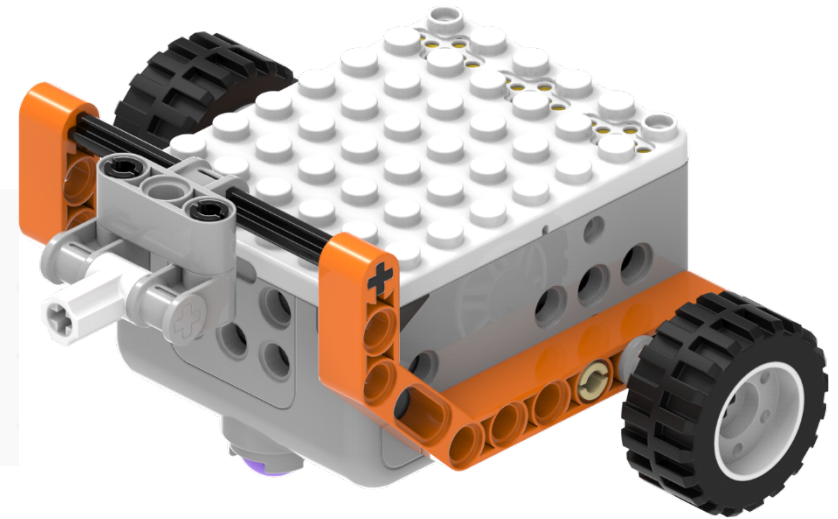



Play and Try

Get ready, competitors—tug-of-war is about to begin!

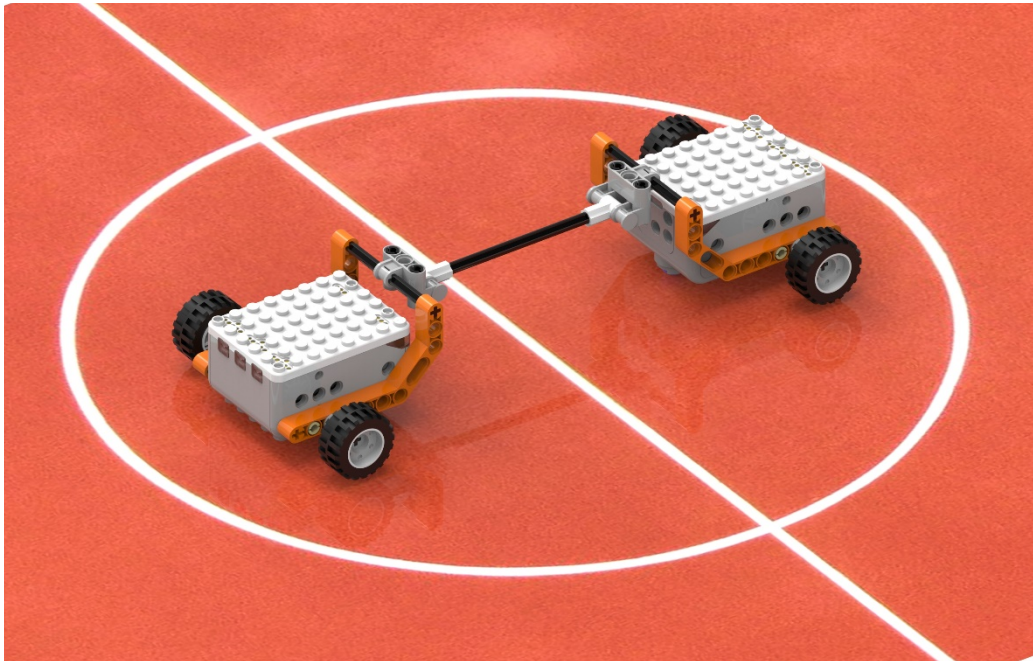

Kids, is there a way to make the Superbot tug-of-war even more powerful?

CREATION





Create

1. Change the speed

Try increasing the speed value and see if the performance of the Superbot tug-of-war improves.

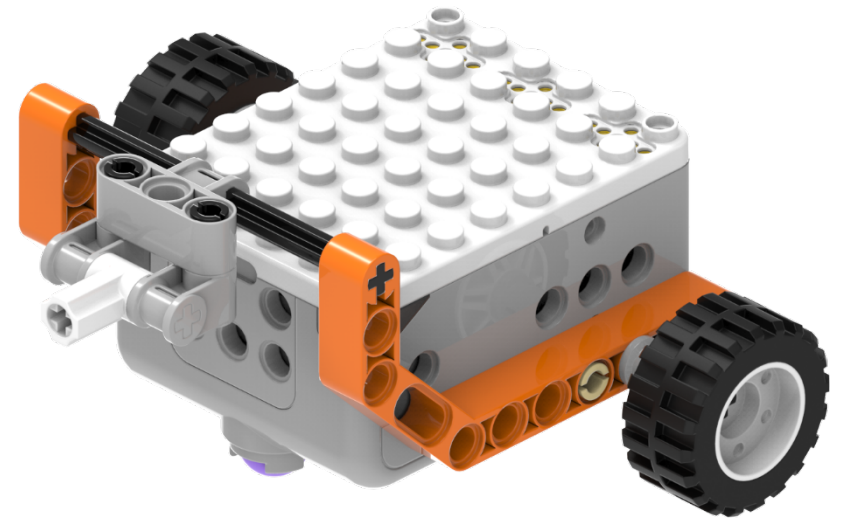
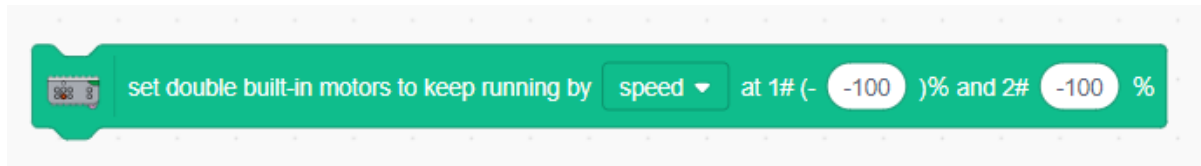
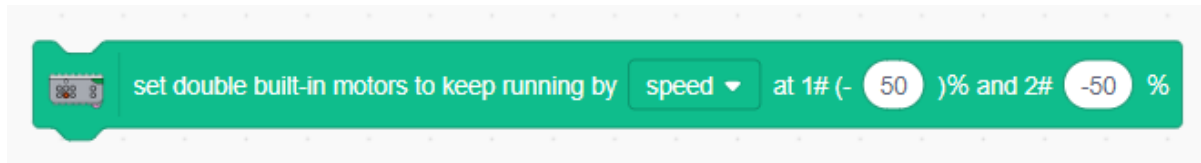



Introductions

Friction :

When an object moves on the surface of another object, a force that opposes the motion is generated at the contact surface between the two objects. This force is called friction.

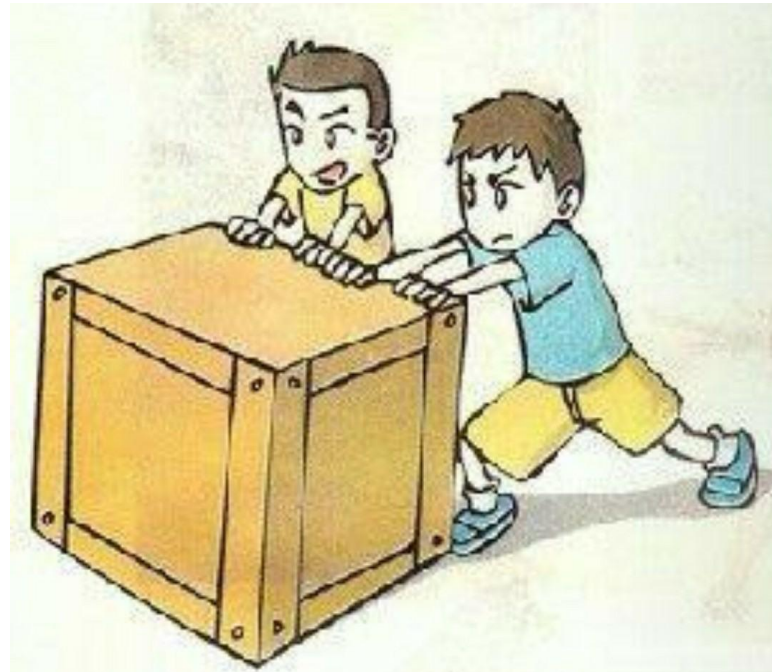



Introductions

Friction

The magnitude of friction is related to the roughness of the contact surface. The smoother the surface, the smaller the friction; the rougher the surface, the greater the friction.



Smooth glass



Rough sandpaper

The magnitude of friction is also related to the amount of pressure. When the roughness of the contact surface is constant, the greater the pressure, the greater the friction.



Light paper is easy to push

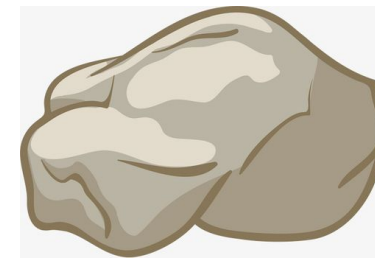

Heavy stone is difficult to move



Create

2. Increase friction

Try to improve the performance of your tug-of-war robots by increasing the pressure or roughness to see whose robot is the best.

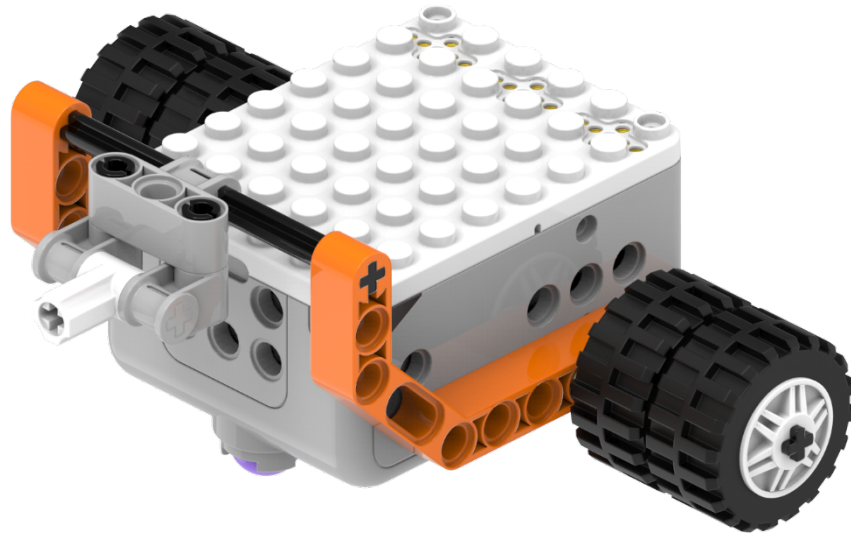

Increase the contact surface roughness

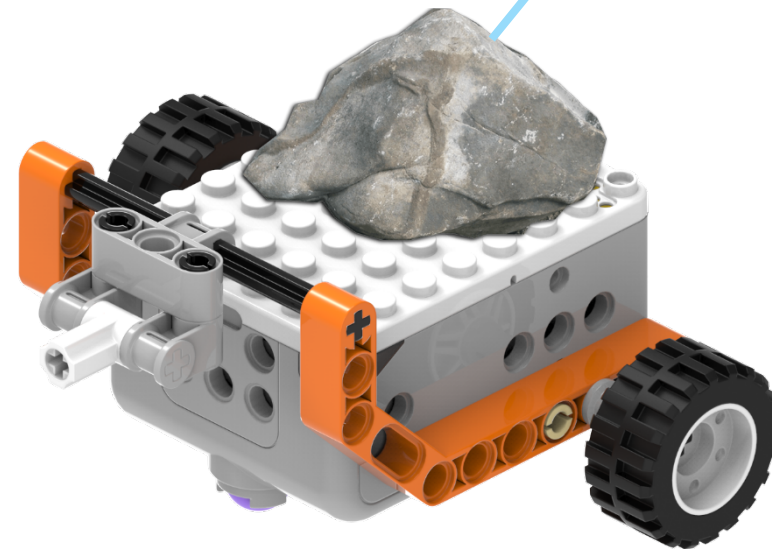

Please add a reasonable load to the trolley

Increased pressure

SUMMARY





Summary

In this lesson, we learned about:

1. Make the car move backward

set double built-in motors to keep running by speed at 1# (-50)% and 2# 50%

set double built-in motors to keep running by speed at 1# (-50)% and 2# 50%

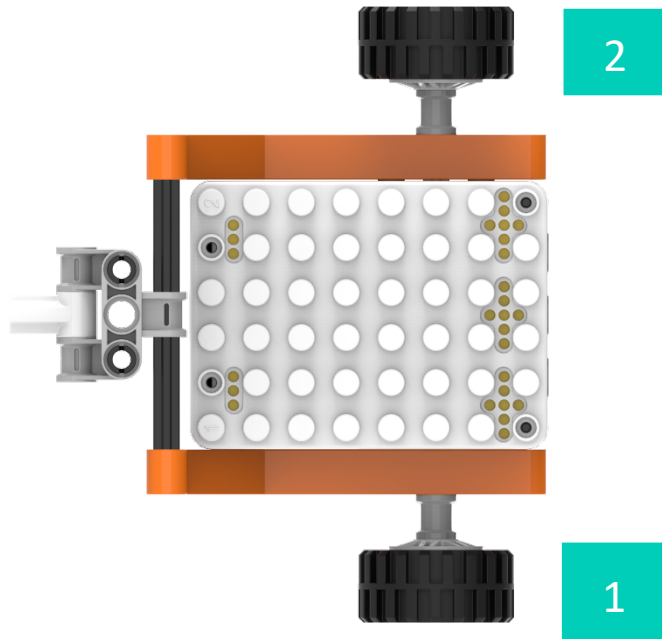

Control the two motors of the Super Robot at the same time.

set ext servo 1# to keep running at 50 (-100~100)% speed on clockwise

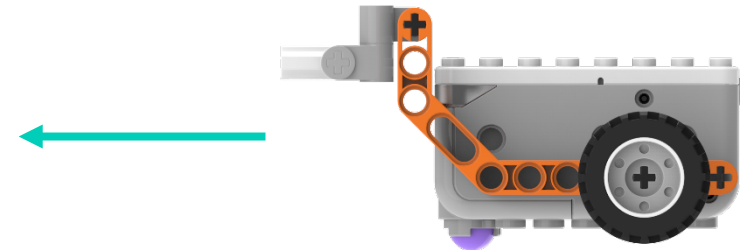

set ext servo 2# to keep running at 50 (-100~100)% speed on clockwise





Summary

2. Friction

When an object moves on the surface of another object, a force that opposes the motion is generated at the contact surface between the two objects. This force is called friction.

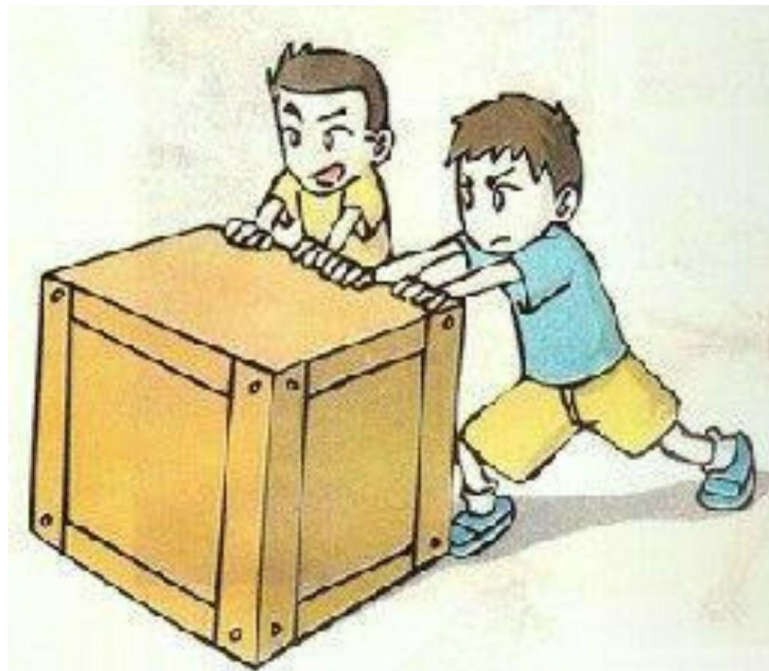



Summary

2. Friction

The magnitude of friction is related to the roughness of the contact surface. The smoother the surface, the smaller the friction; the rougher the surface, the greater the friction.



Smooth glass



Rough sandpaper

The magnitude of friction is also related to the amount of pressure. When the roughness of the contact surface is constant, the greater the pressure, the greater the friction.



Light paper is easy to push

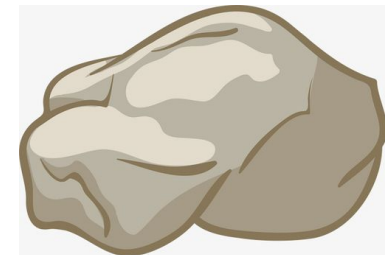

Heavy stone is difficult to move



Summary

3. Tug of War competition

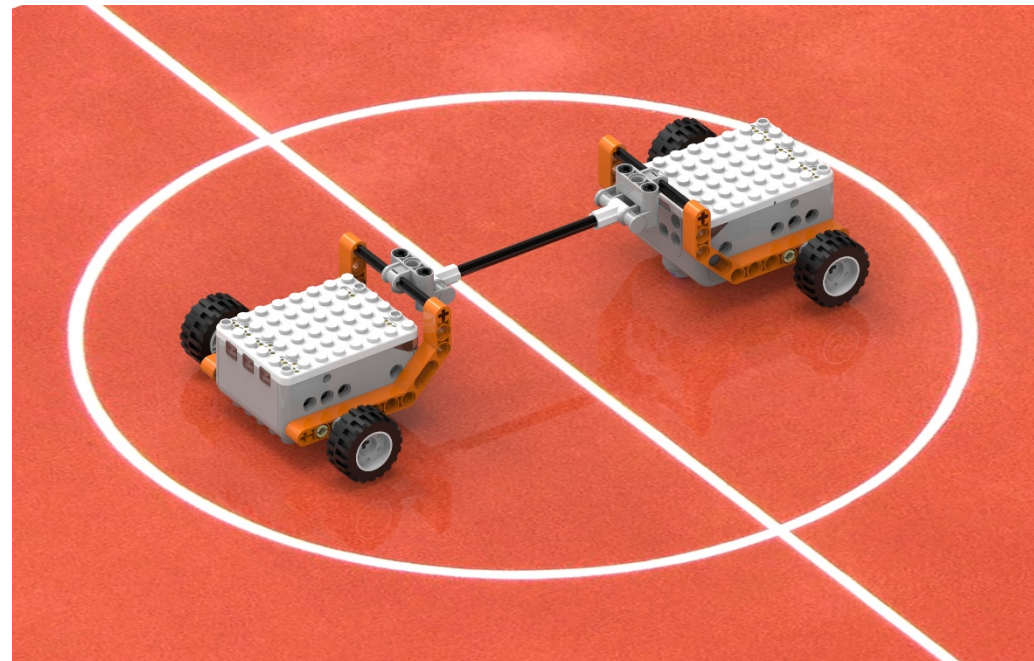

SHARE WITH YOUR PARENTS

Share the knowledge about the Tug-of-war robot with your mom and dad when you get home!

