



# Course Review

1. Make the car move backward

set double built-in motors to keep running by speed at 1# (-50)% and 2# 50%

set double built-in motors to keep running by speed at 1# (-50)% and 2# 50%

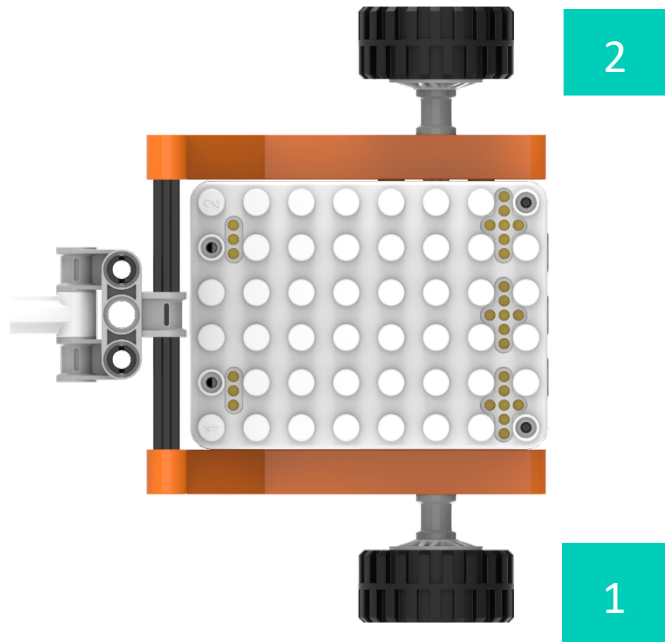

Control the two motors of the Super Robot at the same time.

set ext servo 1# to keep running at 50 (-100~100)% speed on clockwise

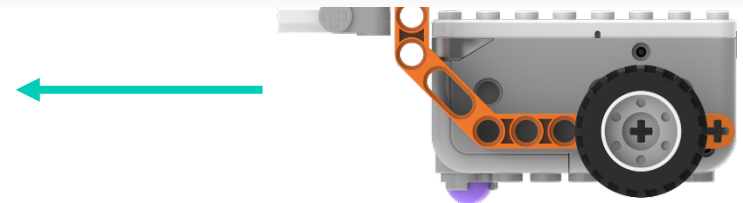

set ext servo 2# to keep running at 50 (-100~100)% speed on clockwise





# Course Review

## 2. Friction

When an object moves on the surface of another object, a force that opposes the motion is generated at the contact surface between the two objects. This force is called friction.

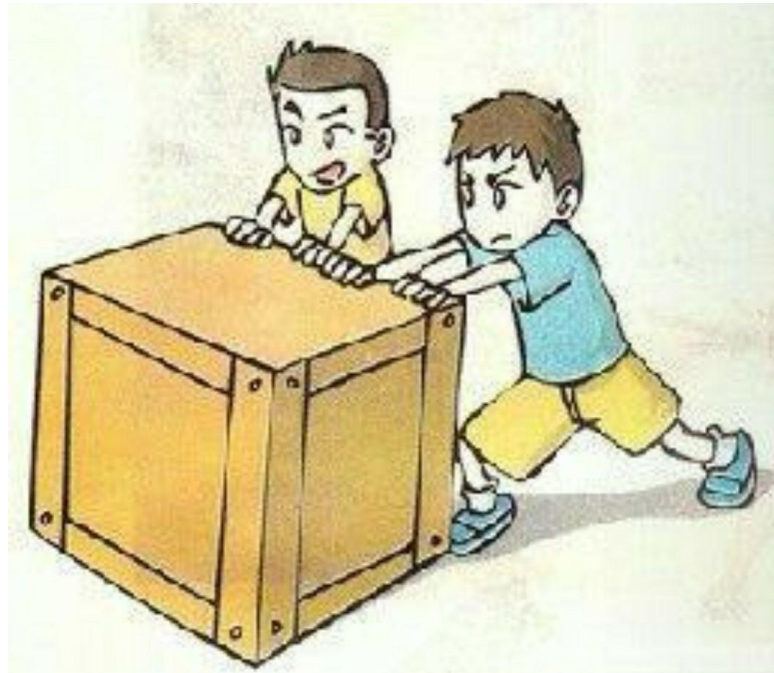



# Course Review

## 2. Friction

The magnitude of friction is related to the roughness of the contact surface. The smoother the surface, the smaller the friction; the rougher the surface, the greater the friction.

The magnitude of friction is also related to the amount of pressure. When the roughness of the contact surface is constant, the greater the pressure, the greater the friction.



Smooth glass



Rough sandpaper



Light paper is easy to push

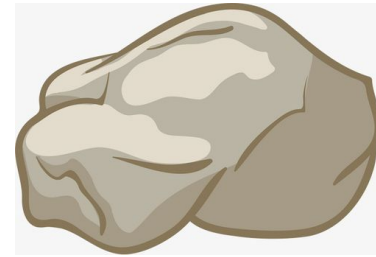

Heavy stone is difficult to move



# Course Review

## 3. Tug of War competition

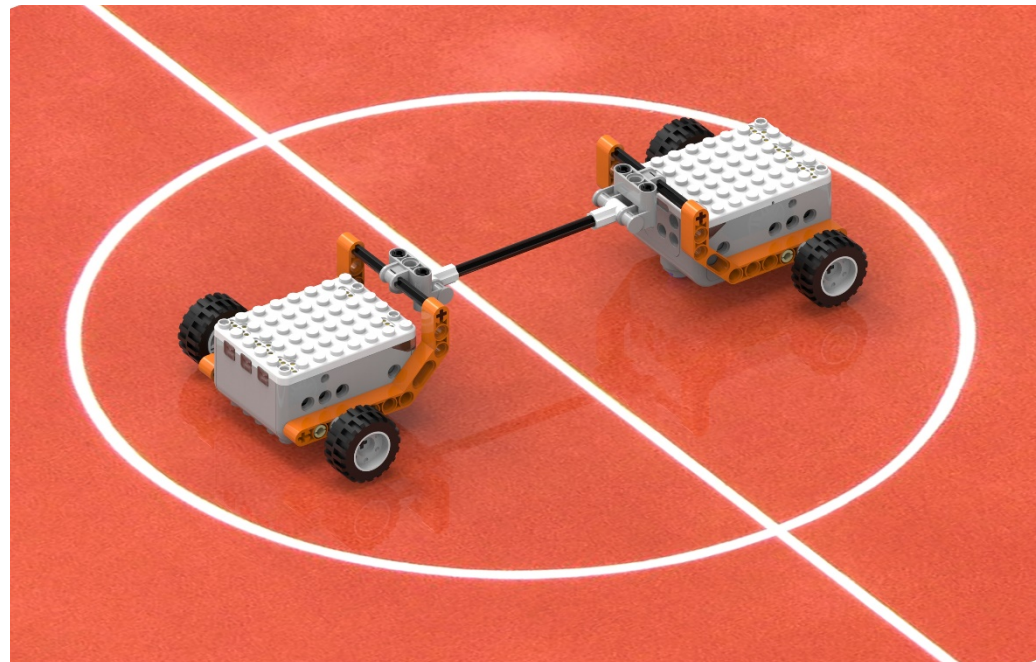

**Please use your own kit.**

**Do not put any parts in your mouth.**

**Please clean up after use.**

**Please raise your hand if you have any questions.**



# INTRODUCTION

---





# Scenarios

Sumo is a type of competitive sport. It originated in China during the Spring and Autumn Period, where it was known as "Jiaodi" from the Spring and Autumn to the Qin and Han periods, with a focus on martial arts. From the Northern and Southern Dynasties to the Southern Song Dynasty, it became known as "Sumo." After being introduced to Japan during the Tang Dynasty, sumo became a popular sport.

In the Song Dynasty, sumo split from martial arts, focusing only on grappling without punching or kicking. Victory is achieved by toppling the opponent. The modern rules of sumo are quite similar to these.



How can we make the sumo robot run automatically?

How can we improve the performance of the sumo robot?

Do you want to have your own sumo robot?

Let's work together to build a "sumo robot" and embark on our journey of exploration!



# Sumo Competition

AI Courses





# Scenarios

## Question :

Dear kids, Do you know

1. How can we make the sumo robot run automatically?
2. How can we improve the performance of the sumo robot?

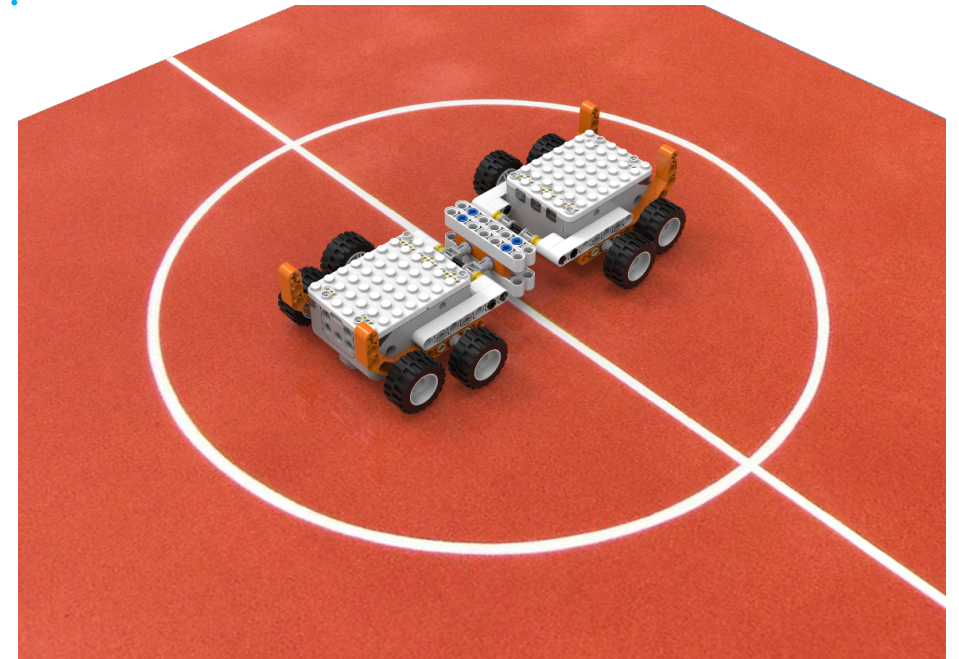



# Scenarios

Today, you are all little engineers. Let's build the Sumo Robot together!

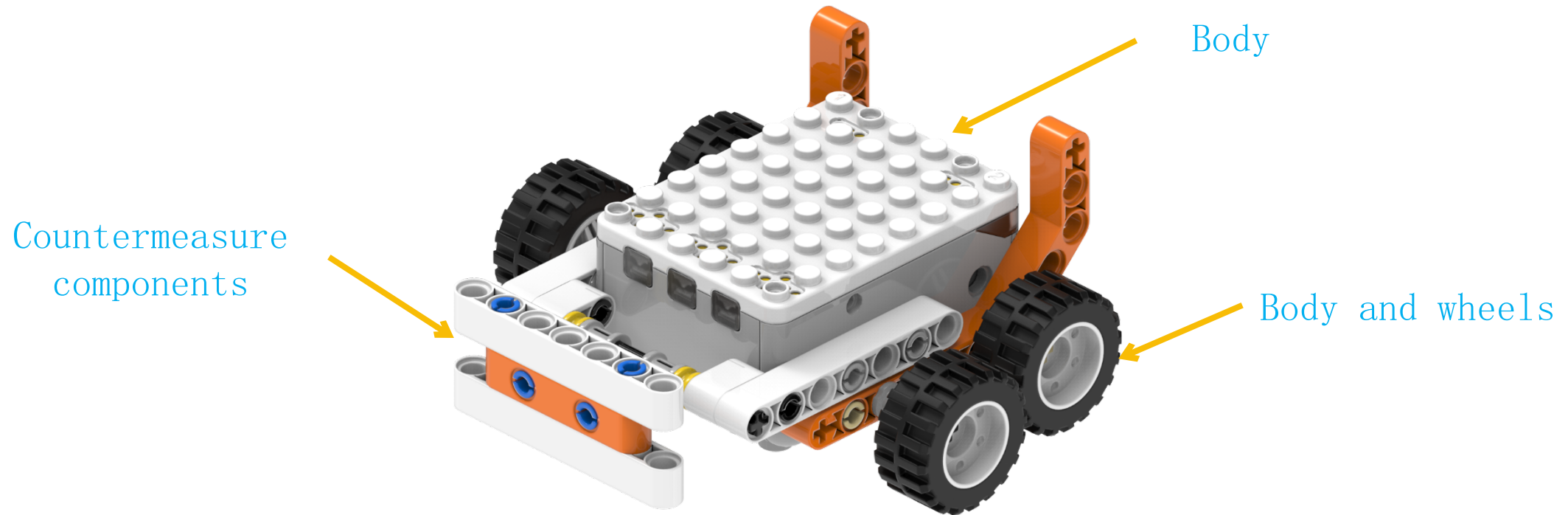

# ASSEMBLY

---





# The Final Model

Assembling the countermeasure components and body

Countermeasure components

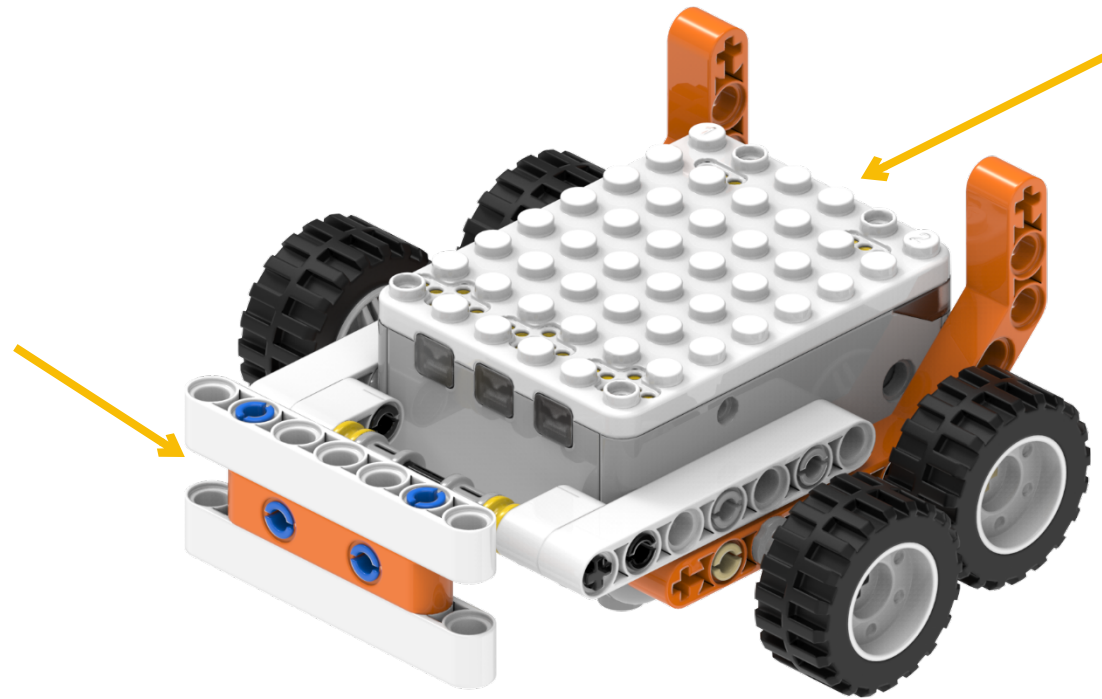

Body



# Assembly

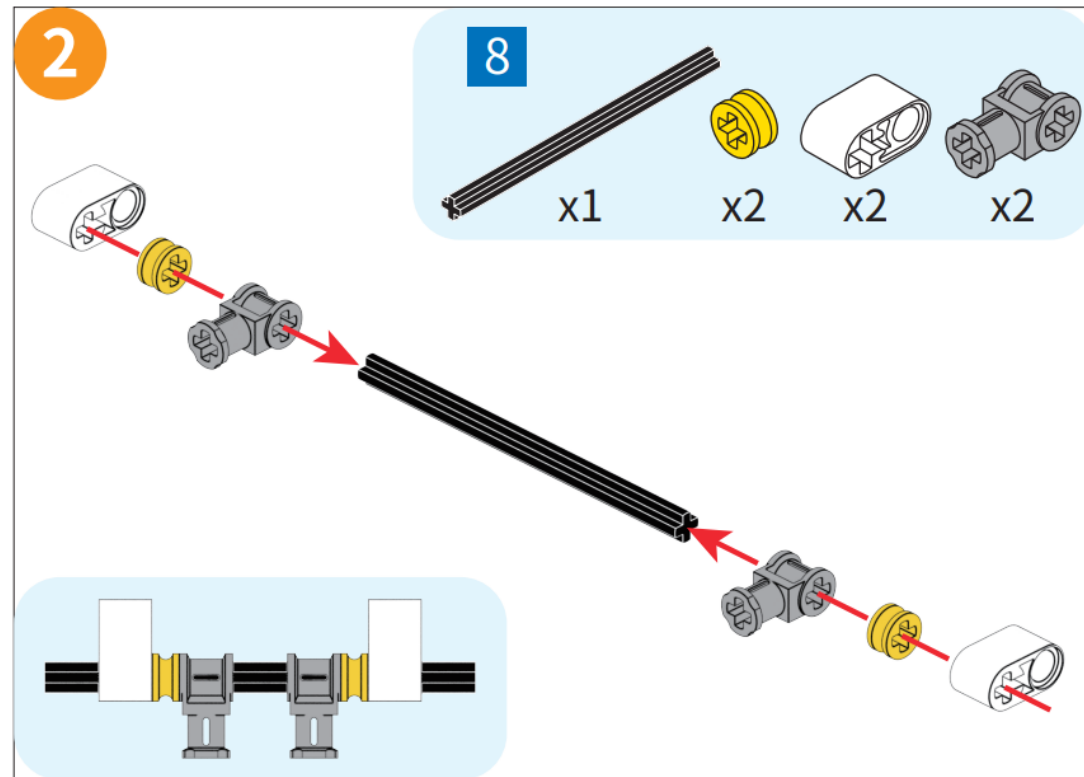
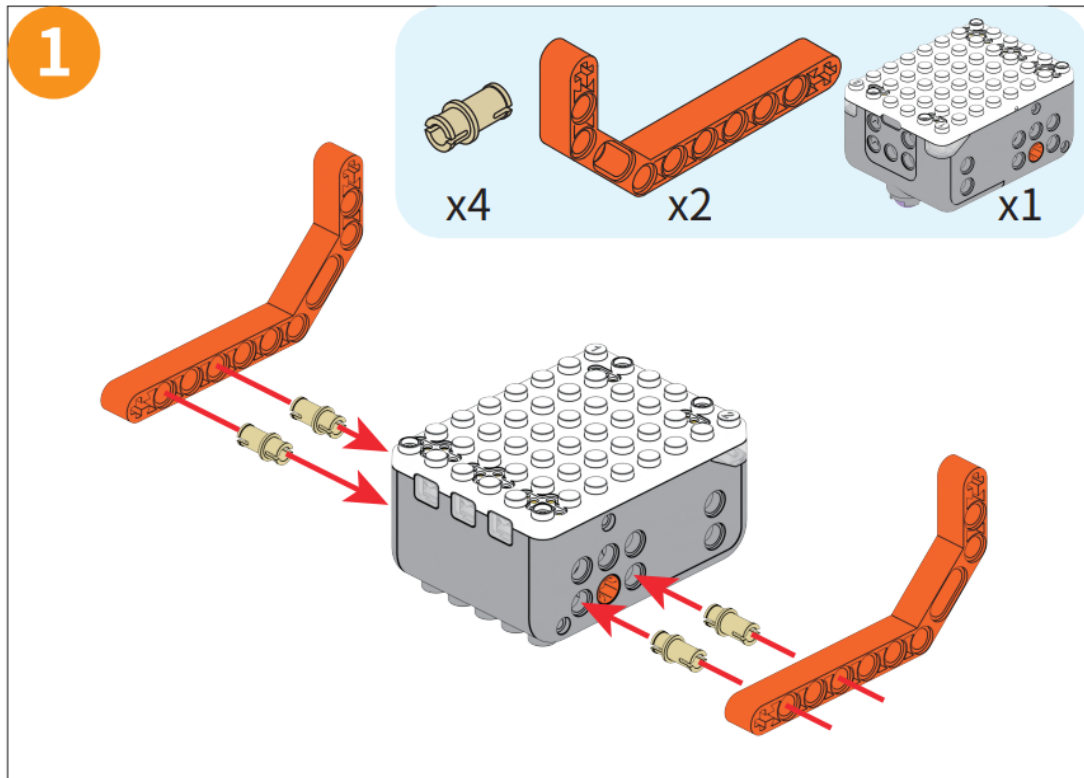



# Assembly

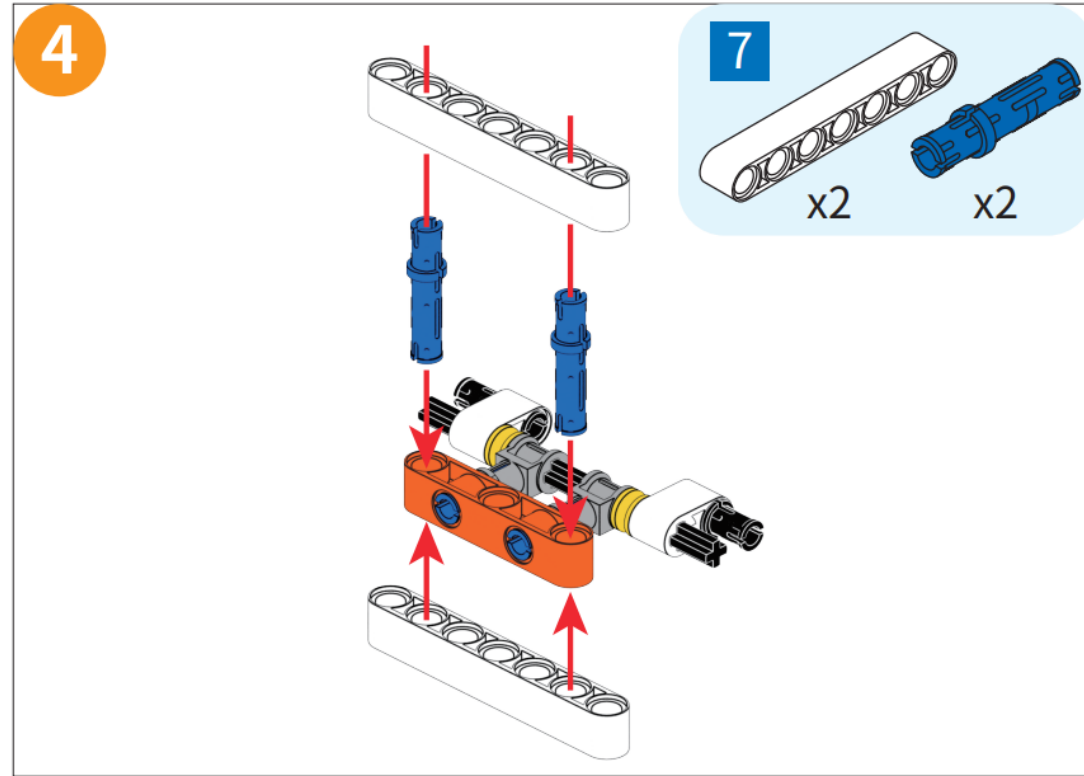
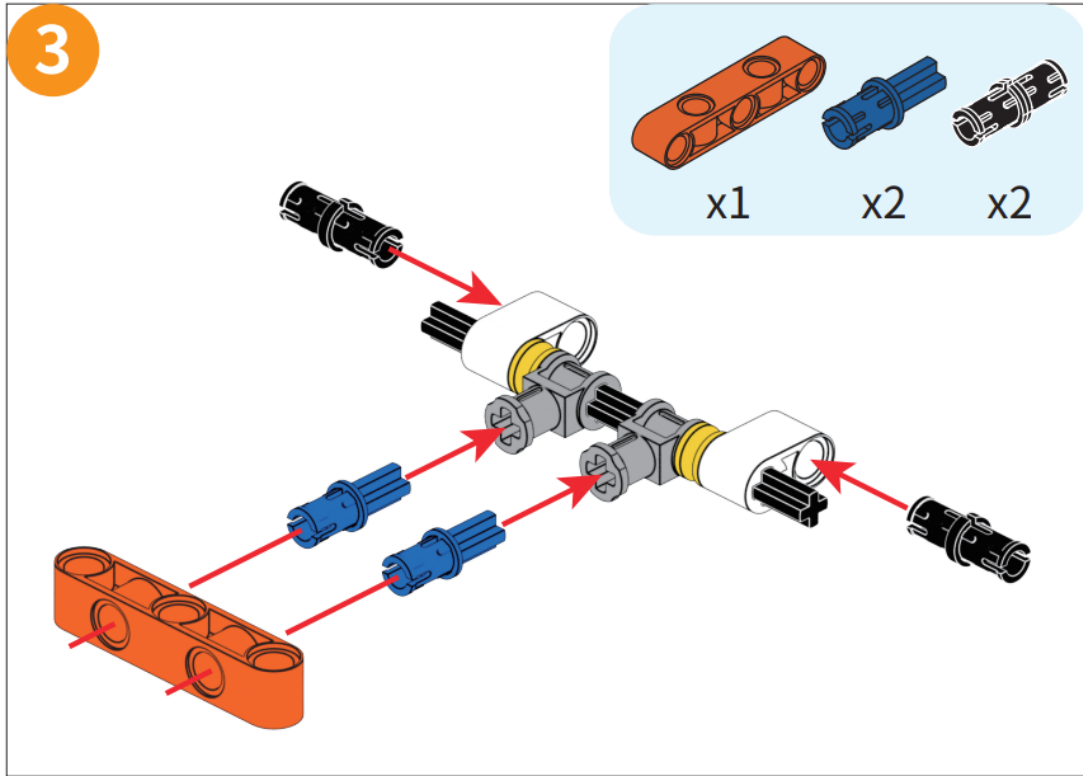



# The Final Model

Assembling the body and wheels

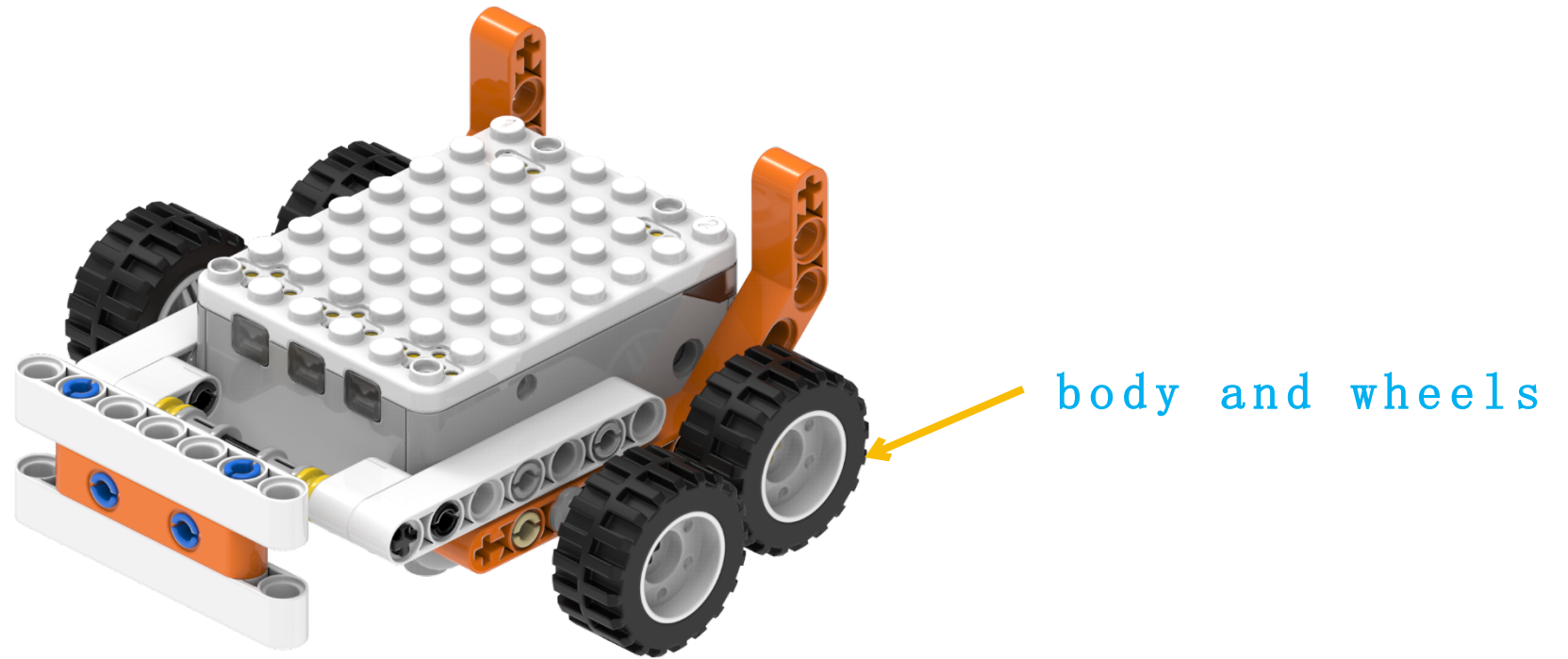



# Assembly

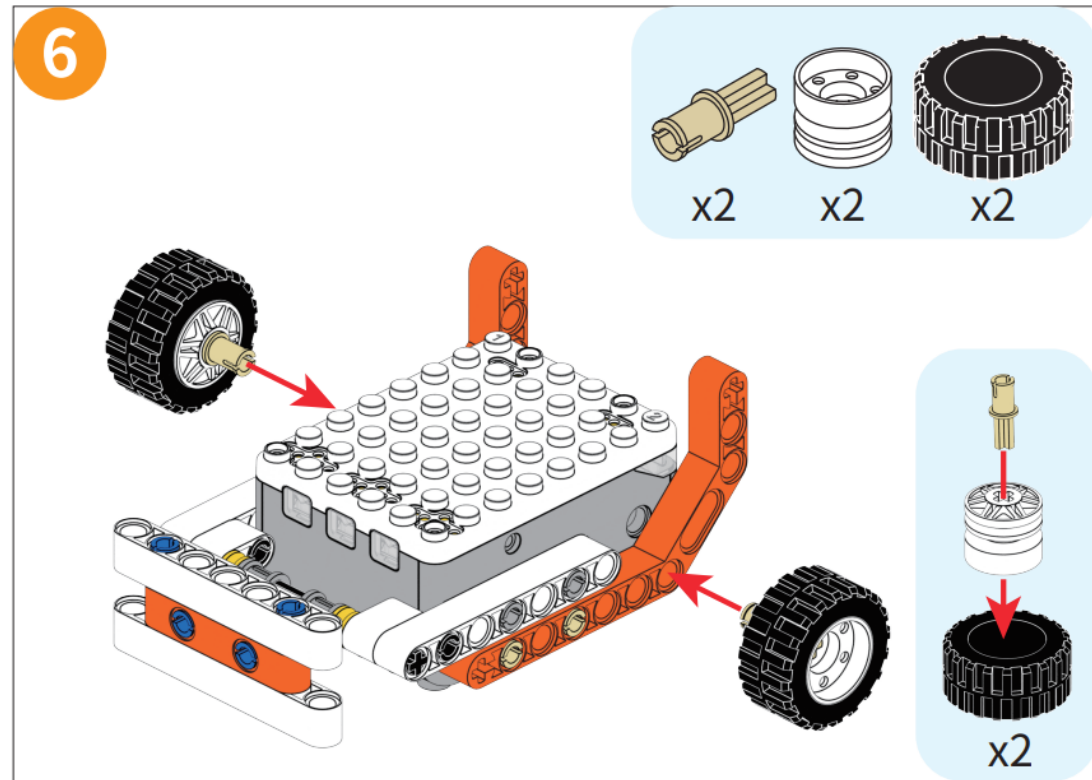
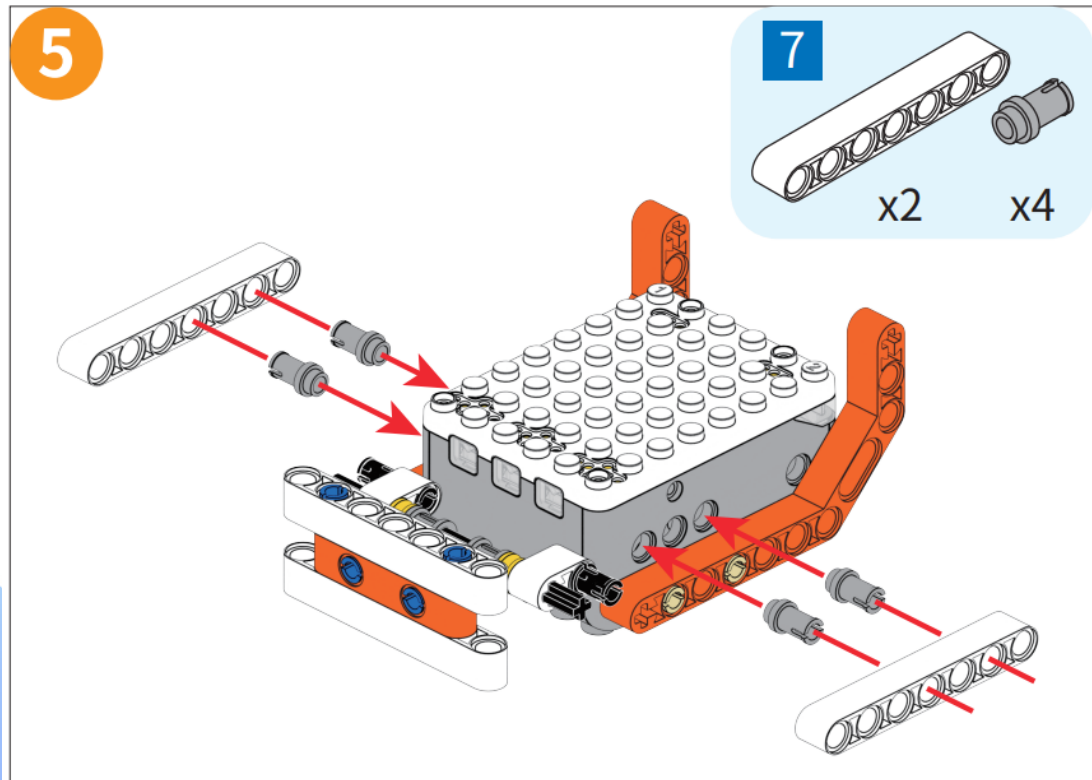



# Assembly

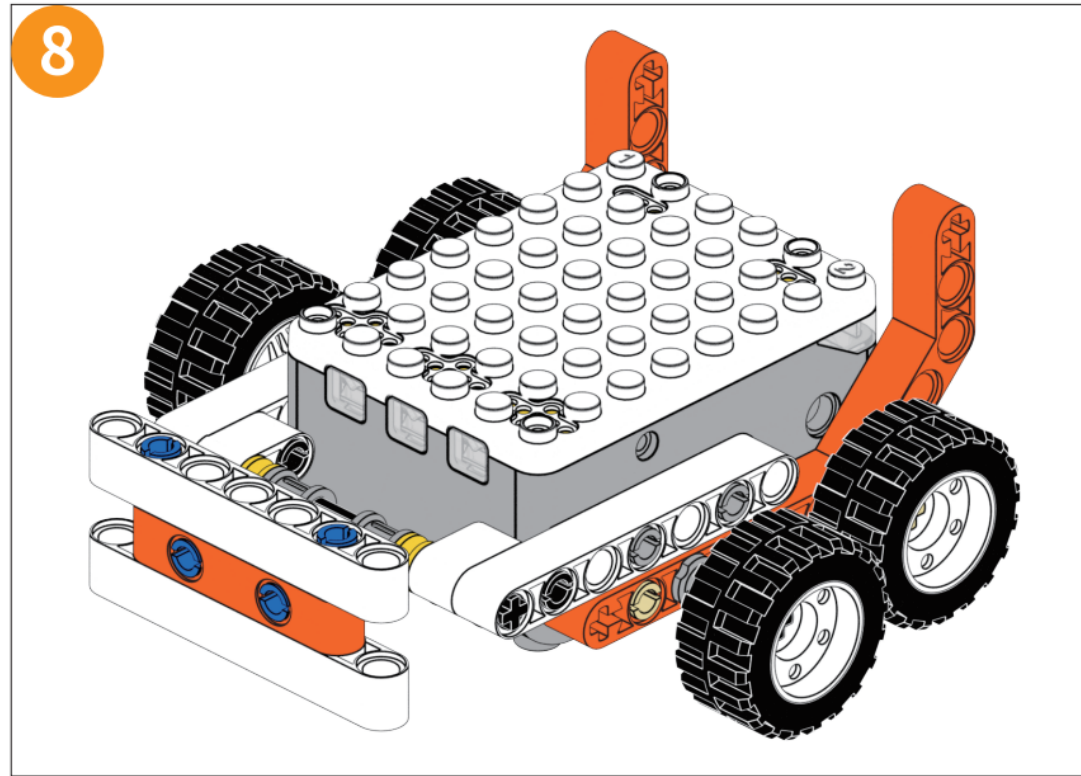
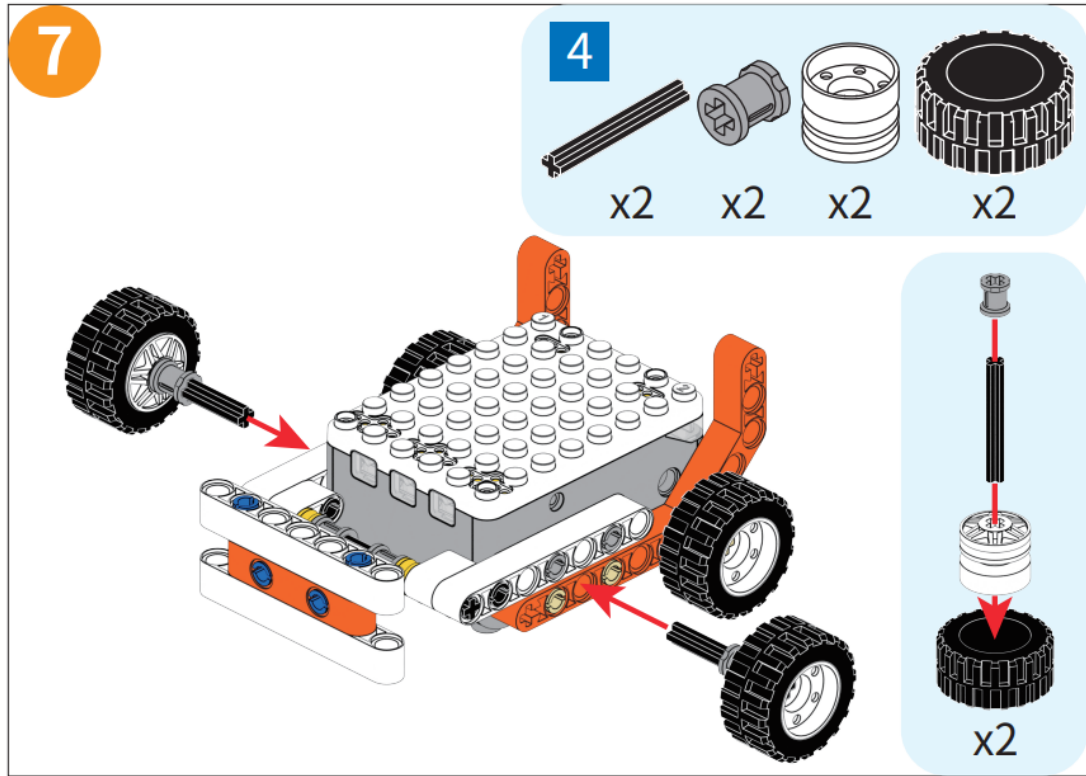

# PROGRAMMING

---





# Introductions

## Module Explanation

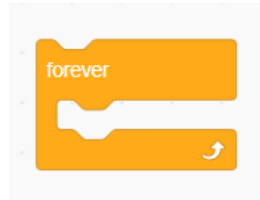

Make the Superbot Master program to repeatedly perform specific tasks.

Repeat

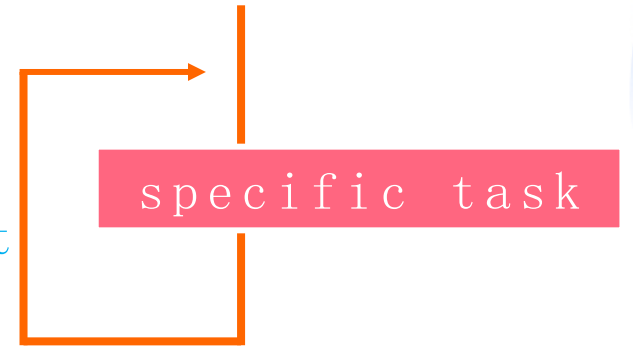

Repeat

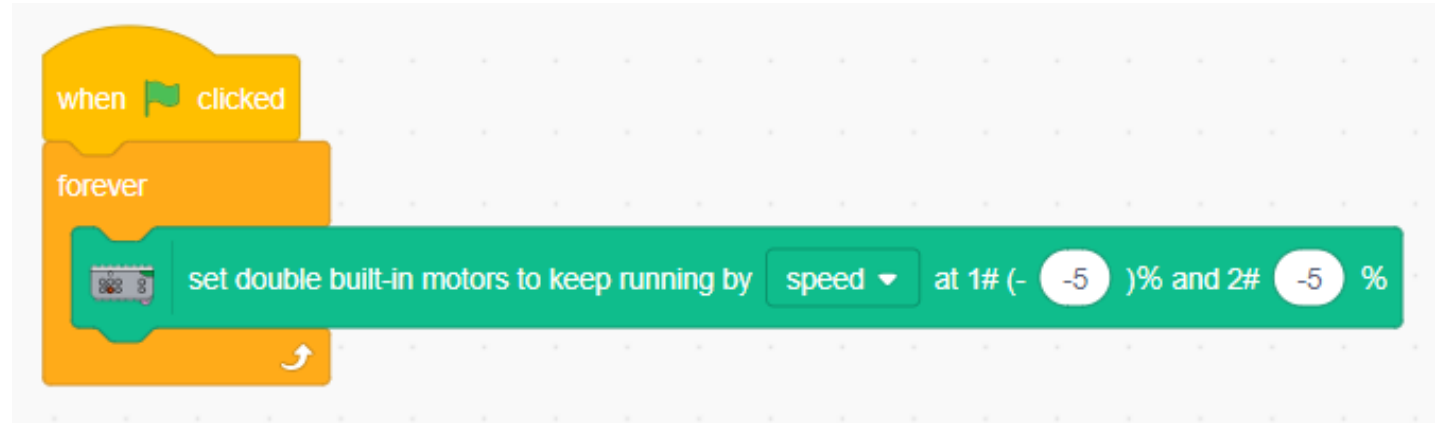
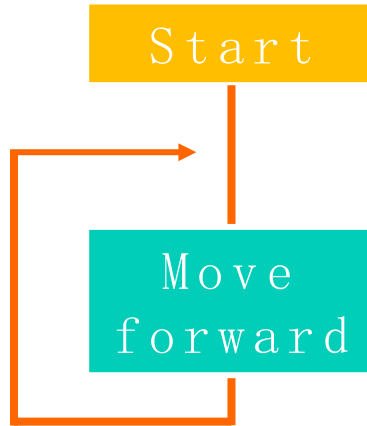



# Play and Try

## Let's give it a try:

Click the Start button to see if the Sumo Robot works properly.



```
when clicked
  forever
    set double built-in motors to keep running by speed at 1# (-5)% and 2# -5%
```

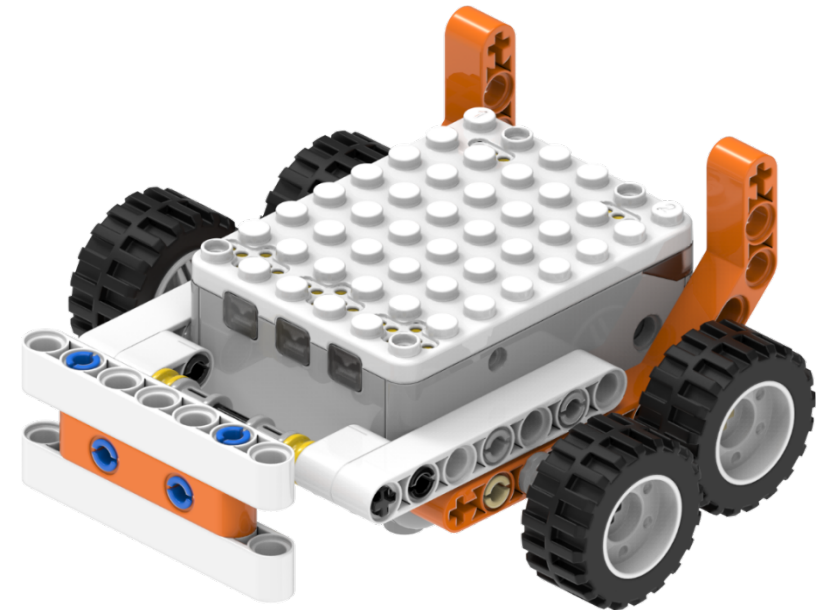



# Play and Try

Get ready, competitors—sumo is about to begin!

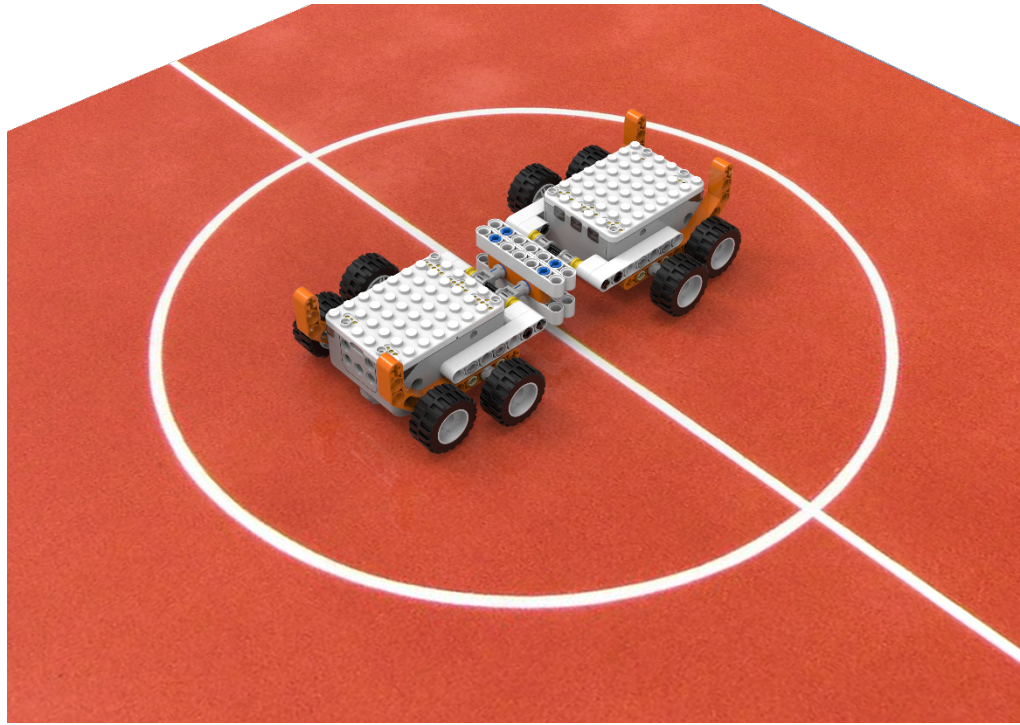

Kids, is there a way to make the sumo even more powerful?

# CREATION

---





# Create

## 1. Change the speed

Try increasing the speed value and see if the performance of the Superbot tug-of-war improves.

set double built-in motors to keep running by speed ▾ at 1# (-50)% and 2# -50%

set double built-in motors to keep running by speed ▾ at 1# (-100)% and 2# -100%

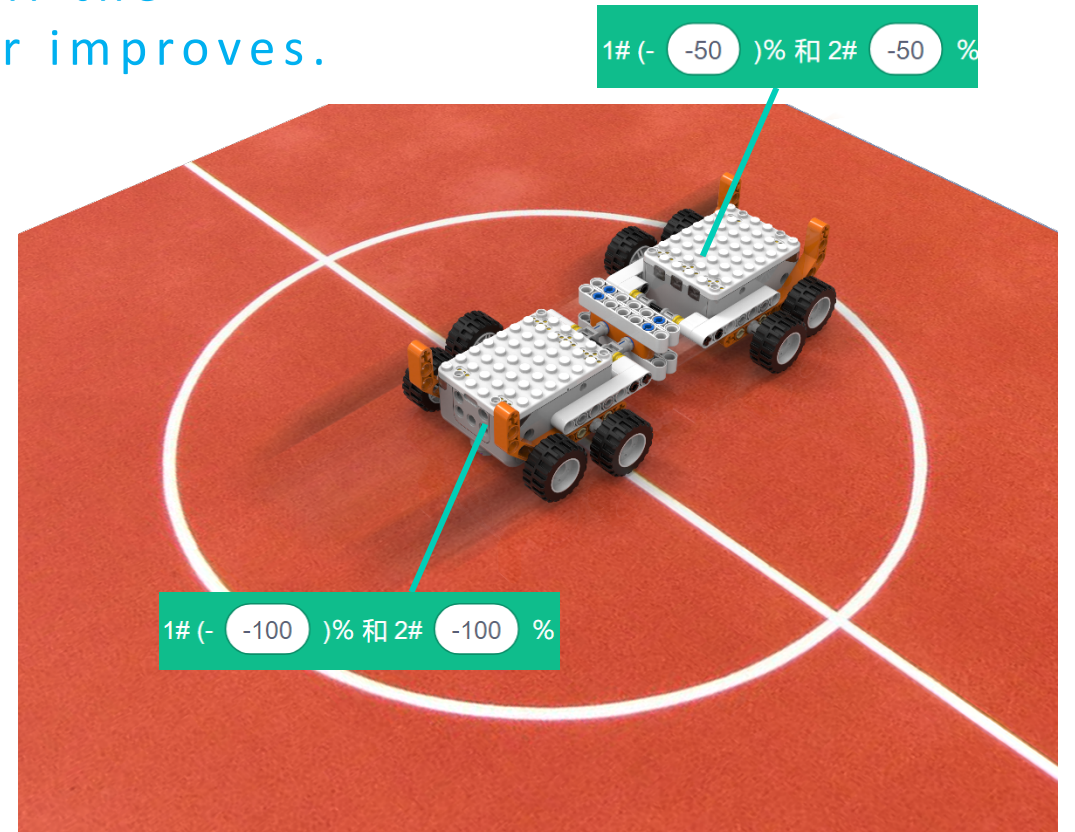



# Introductions

## Four-wheel drive and two-wheel drive:

A car that can only get power from the front wheels or the rear wheels is a two-wheel drive car.

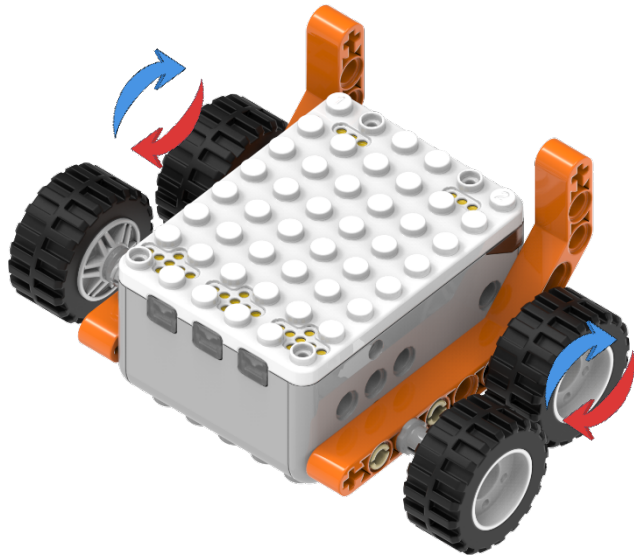

A vehicle that can drive all four wheels is a four-wheel drive vehicle. Off-road vehicles are four-wheel drive vehicles.

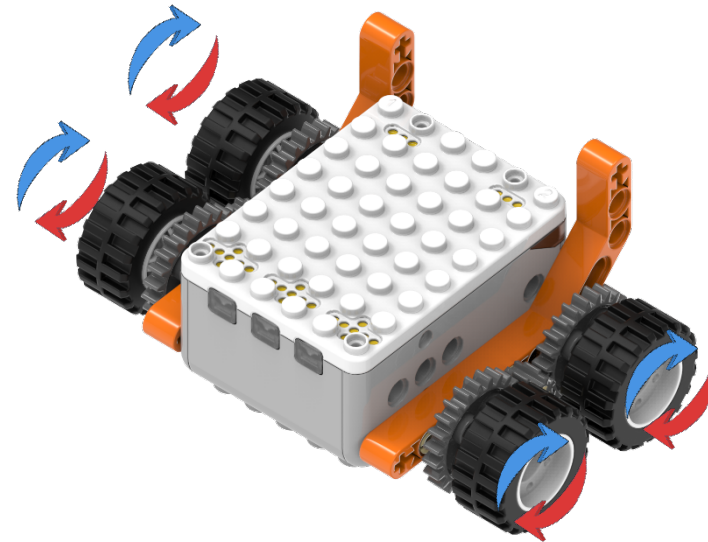



# Create

## 2. Four-wheel drive

Convert the sumo robot to four-wheel drive and see how the performance changes.

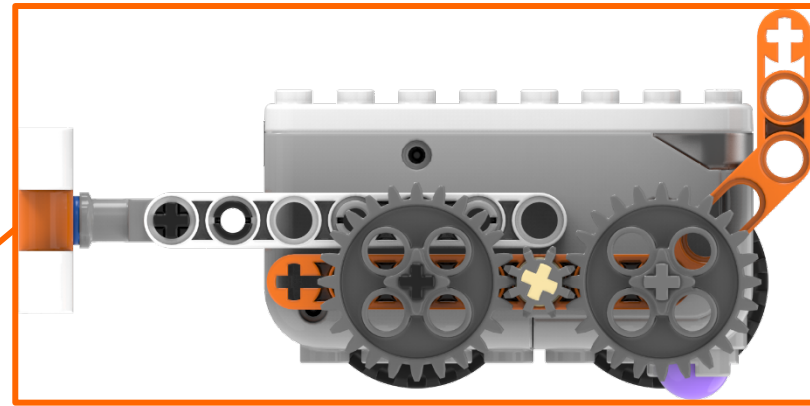
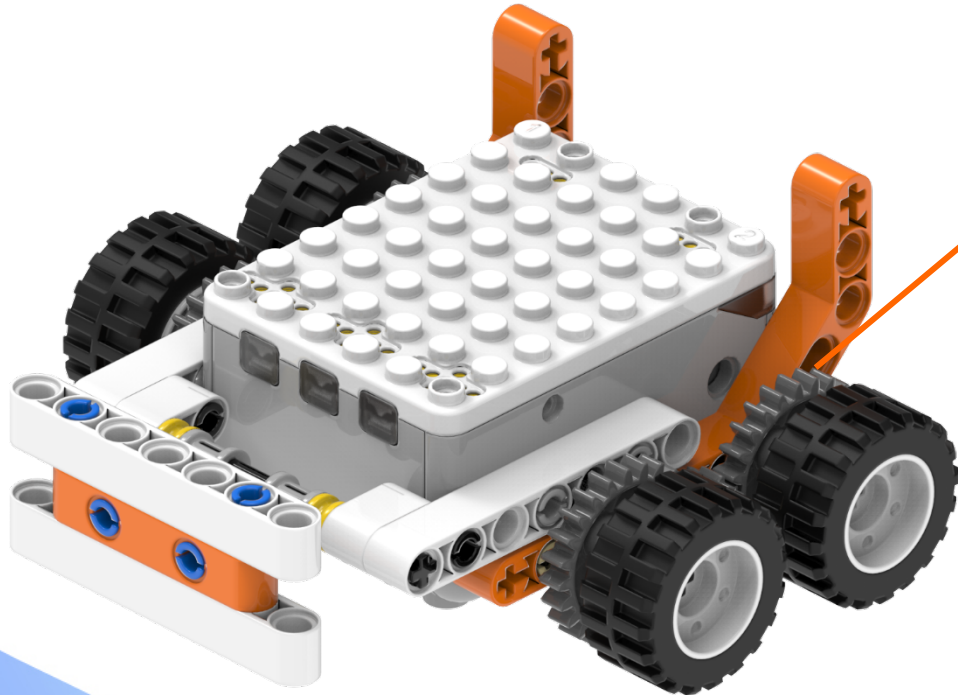



# Create

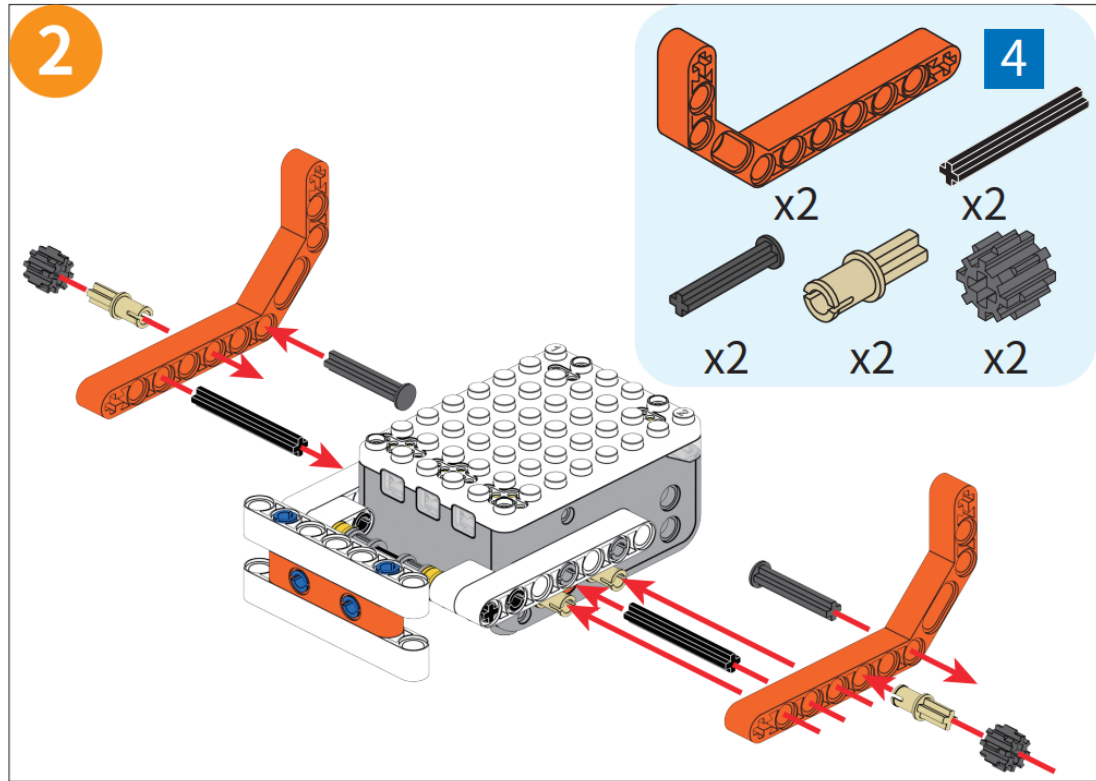
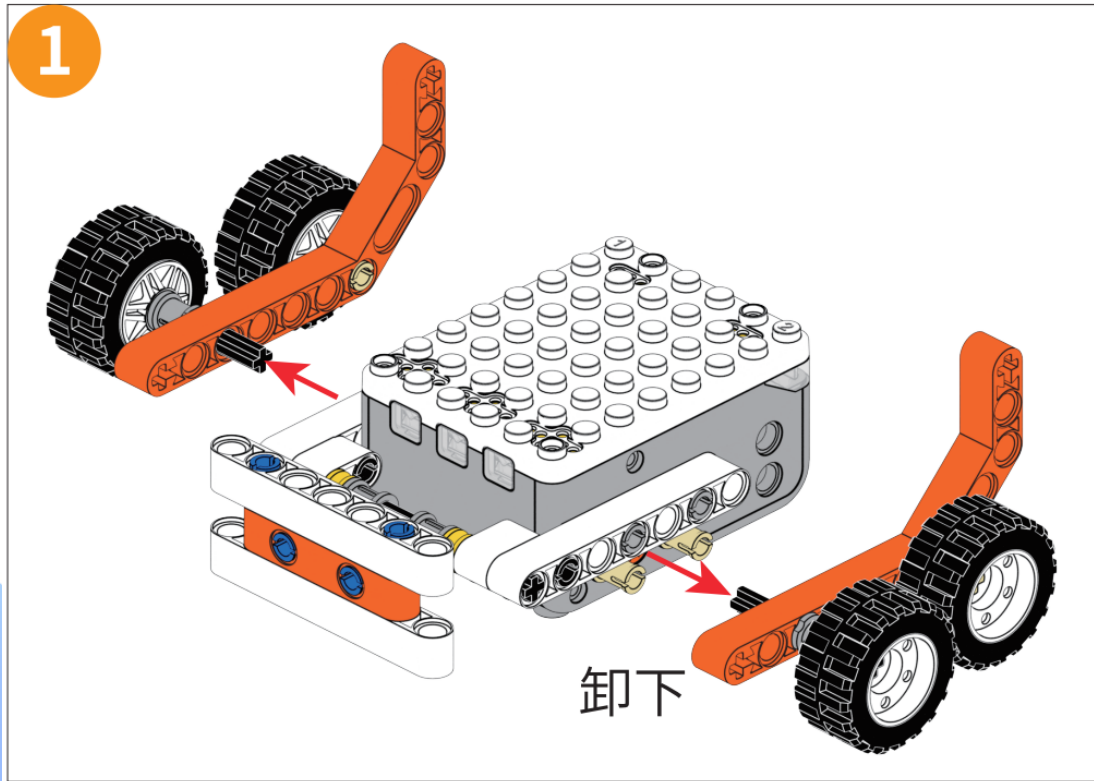



# Create

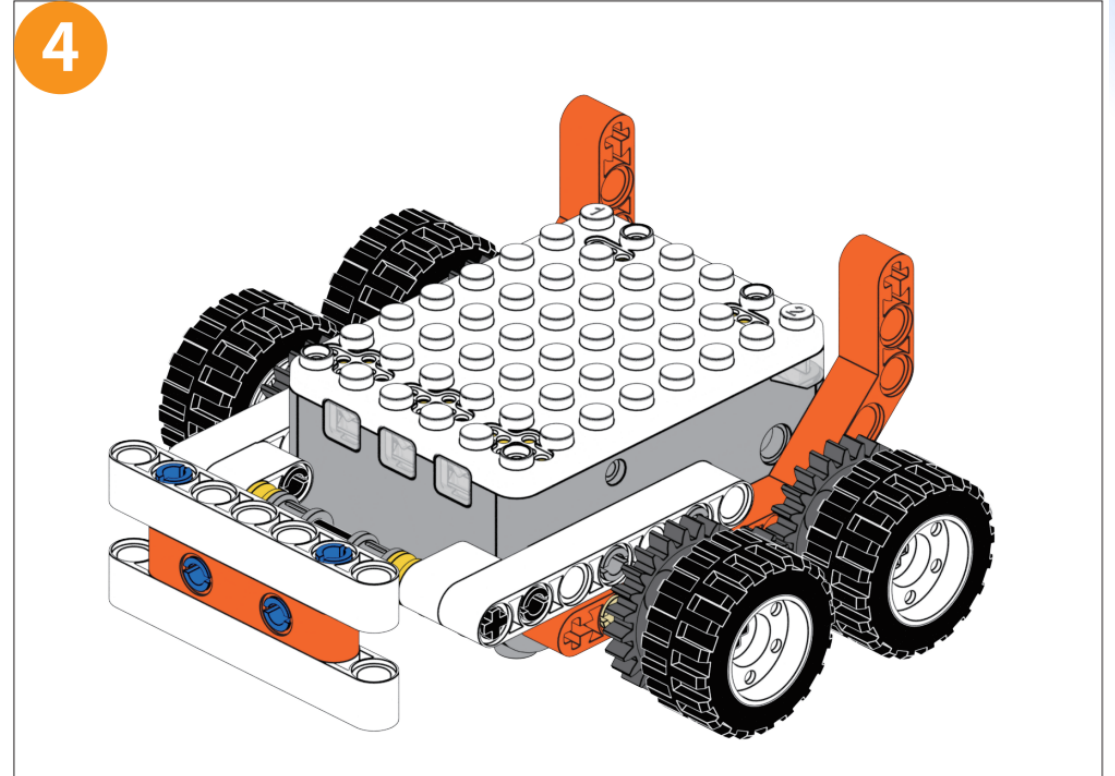
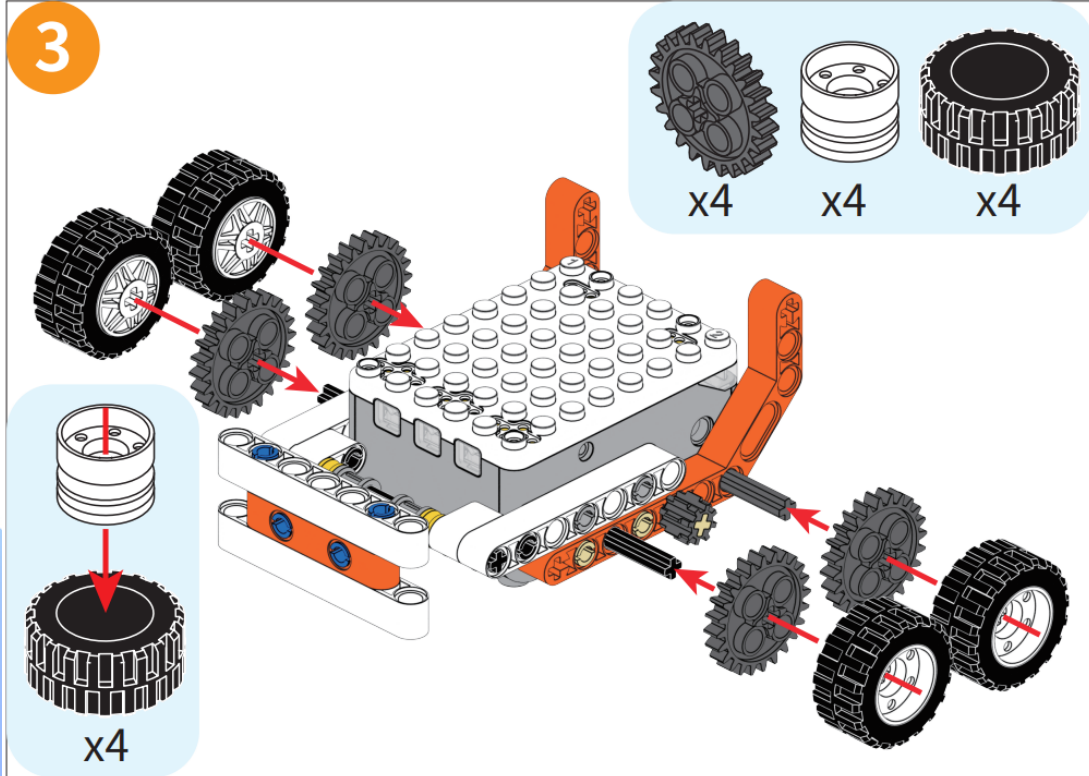

# SUMMARY

---





# Summary

## 1. Repeat

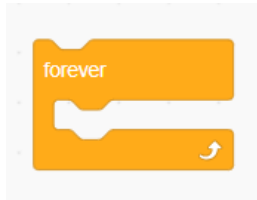

Make the Superbot Master program to repeatedly perform specific tasks.

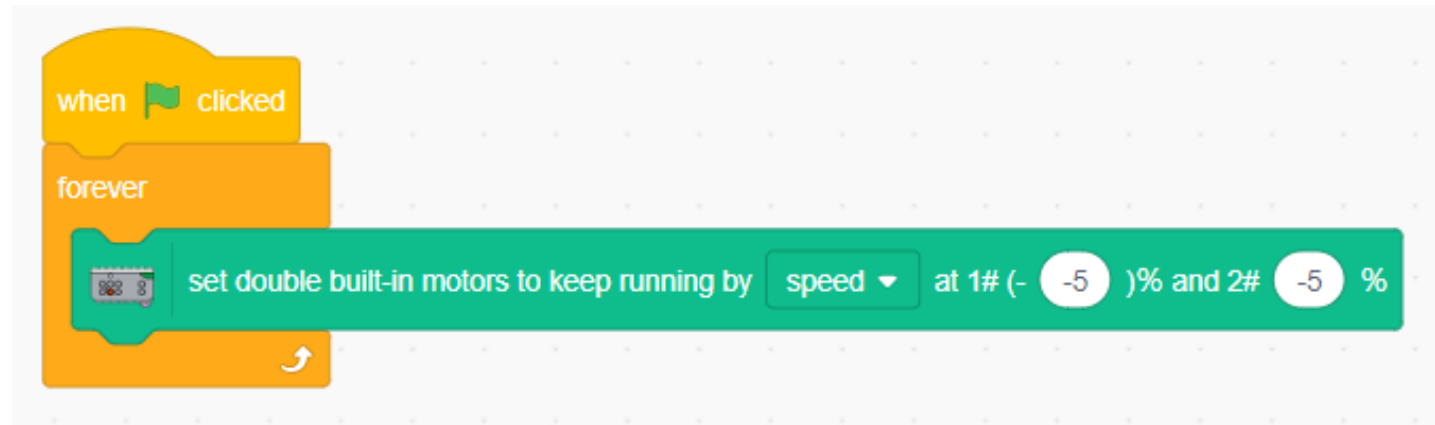
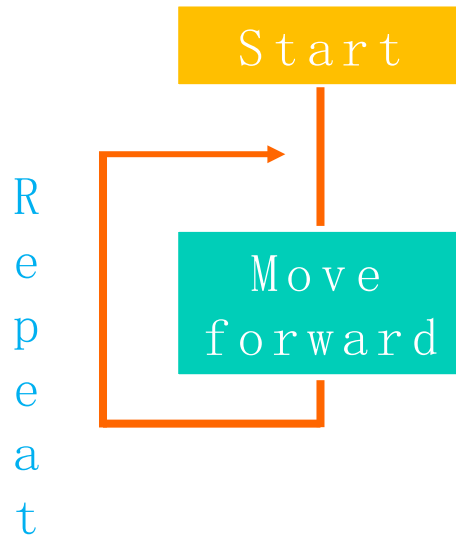
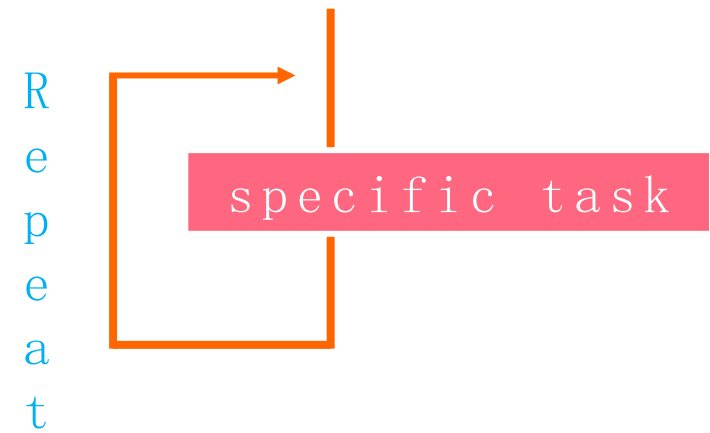



# Summary

## Four-wheel drive and two-wheel drive:

A car that can only get power from the front wheels or the rear wheels is a two-wheel drive car.

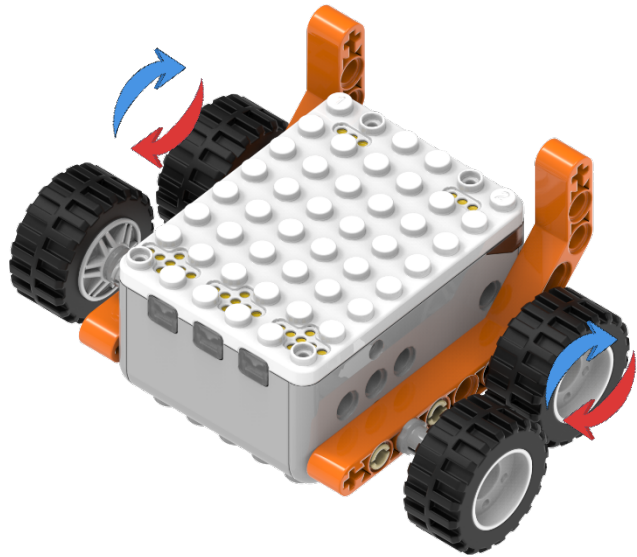

A vehicle that can drive all four wheels is a four-wheel drive vehicle. Off-road vehicles are four-wheel drive vehicles.

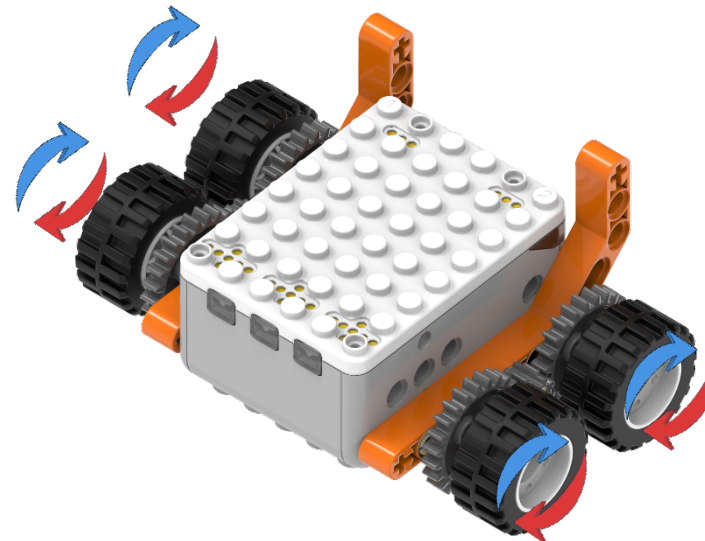



# Summary

## 3. Convert the sumo robot

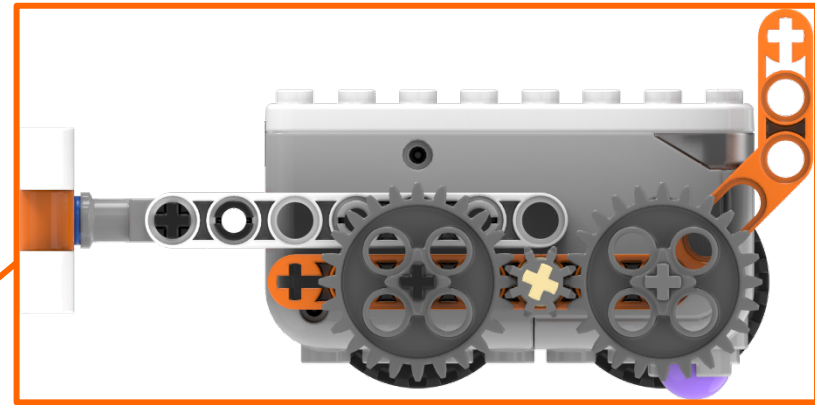
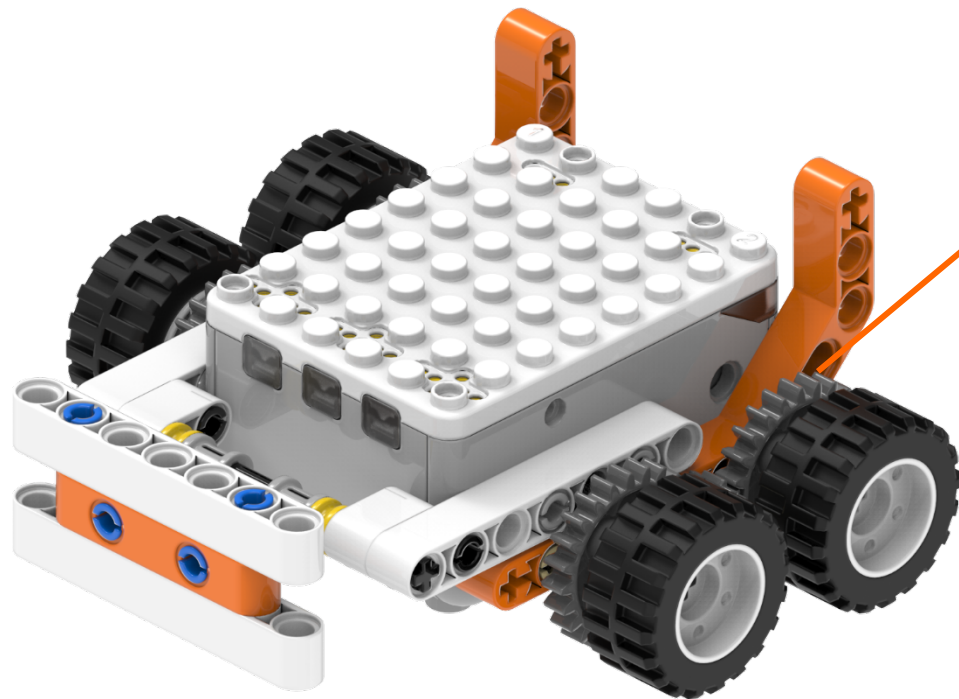

# SHARE WITH YOUR PARENTS

---

Share the knowledge about the Sumo Robot with your mom and dad when you get home!

